

n≈ 1450 rpm

پمپ 65 WKLV4, WKL 4

تیپ پمپ	توان P		آمپر A	قطر پروانه D (mm)	قطر فلنج mm		Q آبدھی							
	KW	HP			مکش	رانس	m3/h	H (m)						
								15	17.5	20	25	30	35	40
						4.17	4.86	5.56	6.95	8.34	9.72	11.1	12.5	
WKLV4 65.1 H	0.75	1	2	155			7.5	7.15	6.7	5.75	4.7	3.5	2	*
WKLV4 65.1 G	1.1	1.5	3	160			8.2	7.85	7.45	6.55	5.45	4.2	2.7	*
WKLV4 65.1 F	1.1	1.5	3	165			8.9	8.6	8.2	7.35	6.2	4.9	3.4	*
WKLV4 65.1 E	1.1	1.5	3	170			9.7	9.4	9.05	8.2	7.05	5.7	4.25	*
WKLV4 65.1 D	1.1	1.5	3	175			10.3	10	9.75	8.95	7.85	6.6	5.25	*
WKLV4 65.1 C	1.5	2	4	180			11	10.8	10.5	9.8	8.8	7.65	6.5	*
WKLV4 65.1 B	1.5	2	4	185			11.8	11.6	11.4	10.7	9.85	8.8	7.6	6.25
WKLV4 65.1 A	2.2	3	5	192			12.75	12.6	12.3	11.7	11	10	9	7.75
WKLV4 65.2 H	1.5	2	4	155			15	14.3	13.4	11.5	9.4	7	4	*
WKLV4 65.2 G	1.5	2	4	160			16.4	15.7	15	13	11	8.4	5.4	*
WKLV4 65.2 F	2.2	3	5	165			17.8	17.2	16.4	14.7	12.4	9.8	6.8	*
WKLV4 65.2 E	2.2	3	5	170			19.4	18.8	18	16.4	14	11.4	8.5	*
WKLV4 65.2 D	2.2	3	5	175			20.8	20.2	19.5	18	15.7	13.2	10.5	*
WKLV4 65.2 C	3	4	7	180			22	21.7	21	19.7	17.7	15.5	13	*
WKLV4 65.2 B	3	4	7	185			23.7	23.3	22.8	21.5	19.7	17.6	15.2	12.5
WKLV4 65.2 A	4	5.5	9	192			25.5	25.2	24.7	23.5	22	20	18	15.5
WKLV4 65.3 H	2.2	3	5	155			22.5	21.4	20	17.2	14	10.5	6	*
WKLV4 65.3 G	2.2	3	5	160			24.6	23.5	22.3	19.6	16.3	12.6	8.1	*
WKLV4 65.3 F	3	4	7	165			26.7	25.8	24.6	22	18.6	14.7	10.2	*
WKLV4 65.3 E	3	4	7	170			29	28.2	27	24.6	21	17	12.7	*
WKLV4 65.3 D	4	5.5	9	175			31.2	30.3	29.2	26.8	23.5	19.8	15.7	*
WKLV4 65.3 C	4	5.5	9	180			33.2	32.5	31.6	29.5	26.5	23.2	19.5	*
WKLV4 65.3 B	5.5	7.5	12	185			35.6	35	34.2	32.2	29.6	26.4	22.8	18.7
WKLV4 65.3 A	5.5	7.5	12	192			38.3	37.8	37	35.2	33	30	27	23.2
WKLV4 65.4 H	3	4	7	155	80	65	30	28.6	26.8	23	18.8	14	8	*
WKLV4 65.4 G	3	4	7	160			32.8	31.4	29.8	26.2	21.8	16.8	10.8	*
WKLV4 65.4 F	4	5.5	9	165			35.6	34.4	32.8	29.4	24.8	19.6	13.6	*
WKLV4 65.4 E	4	5.5	9	170			38.8	37.6	36.2	32.8	28.2	22.8	17	*
WKLV4 65.4 D	5.5	7.5	12	175			41.6	40.4	39	35.8	31.4	26.4	21	*
WKLV4 65.4 C	5.5	7.5	12	180			44.3	43.4	42.2	39.4	35.4	31	26	*
WKLV4 65.4 B	7.5	10	16	185			47.4	46.6	45.6	43	39.4	35.2	30.4	25
WKLV4 65.4 A	7.5	10	16	192			51	50.4	49.4	47	44	40.2	36	31
WKLV4 65.5 H	4	5.5	9	155			37.5	35.7	33.5	28.7	23.5	17.5	10	*
WKLV4 65.5 G	4	5.5	9	160			41	39.2	37.2	32.7	27.2	21	13.5	*
WKLV4 65.5 F	5.5	7.5	12	165			44.5	43	41	36.7	31	24.5	17	*
WKLV4 65.5 E	5.5	7.5	12	170			48.5	47	45.2	41	35.2	28.5	21.2	*
WKLV4 65.5 D	5.5	7.5	12	175			52	50.5	48.7	44.7	39.2	33	26.2	*
WKLV4 65.5 C	7.5	10	16	180			55.4	54.2	52.7	49.2	44.2	38.7	32.5	*
WKLV4 65.5 B	7.5	10	16	185			59.2	58.2	57	53.7	49.2	44	38	31.2
WKLV4 65.5 A	11	15	22	192			63.8	63	61.7	58.7	55	50.2	45	38.7
WKLV4 65.6 H	4	5.5	9	155			45	43	40.2	34.5	28.2	21	12	*
WKLV4 65.6 G	5.5	7.5	12	160			49.2	47	44.7	39.3	32.7	25.2	16.2	*
WKLV4 65.6 F	5.5	7.5	12	165			53.4	51.6	49.2	44	37.2	29.4	20.4	*
WKLV4 65.6 E	7.5	10	16	170			58.2	56.4	54.3	49.2	42.3	34.2	25.5	*
WKLV4 65.6 D	7.5	10	16	175			62.4	60.6	58.5	53.7	47	39.6	31.5	*
WKLV4 65.6 C	7.5	10	16	180			66.4	65	63.3	59	53	46.5	39	*
WKLV4 65.6 B	11	15	22	185			71	70	68.4	64.5	59	52.8	45.6	37.5
WKLV4 65.6 A	11	15	22	192			76.5	75.6	74	70.5	66	60.3	54	46.5

H	m	2	4.6	9	15	21	27	34	40	49	58	67	76
	ft	7	15	30	50	70	90	110	130	160	190	220	250

Q	m3/h	15	17.5	20	25	30	35	40	45
	g.p.m	57	66	76	95	114	132	151	170

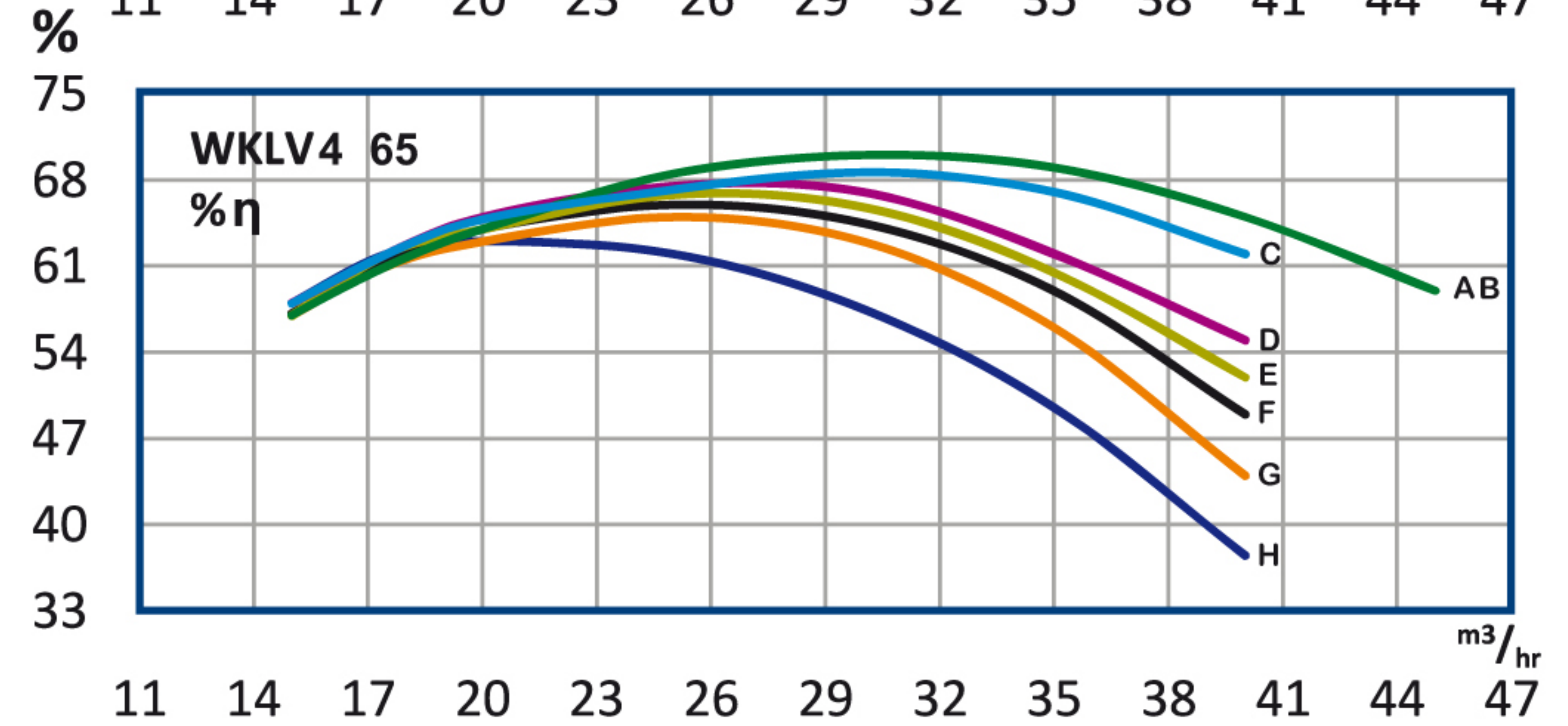
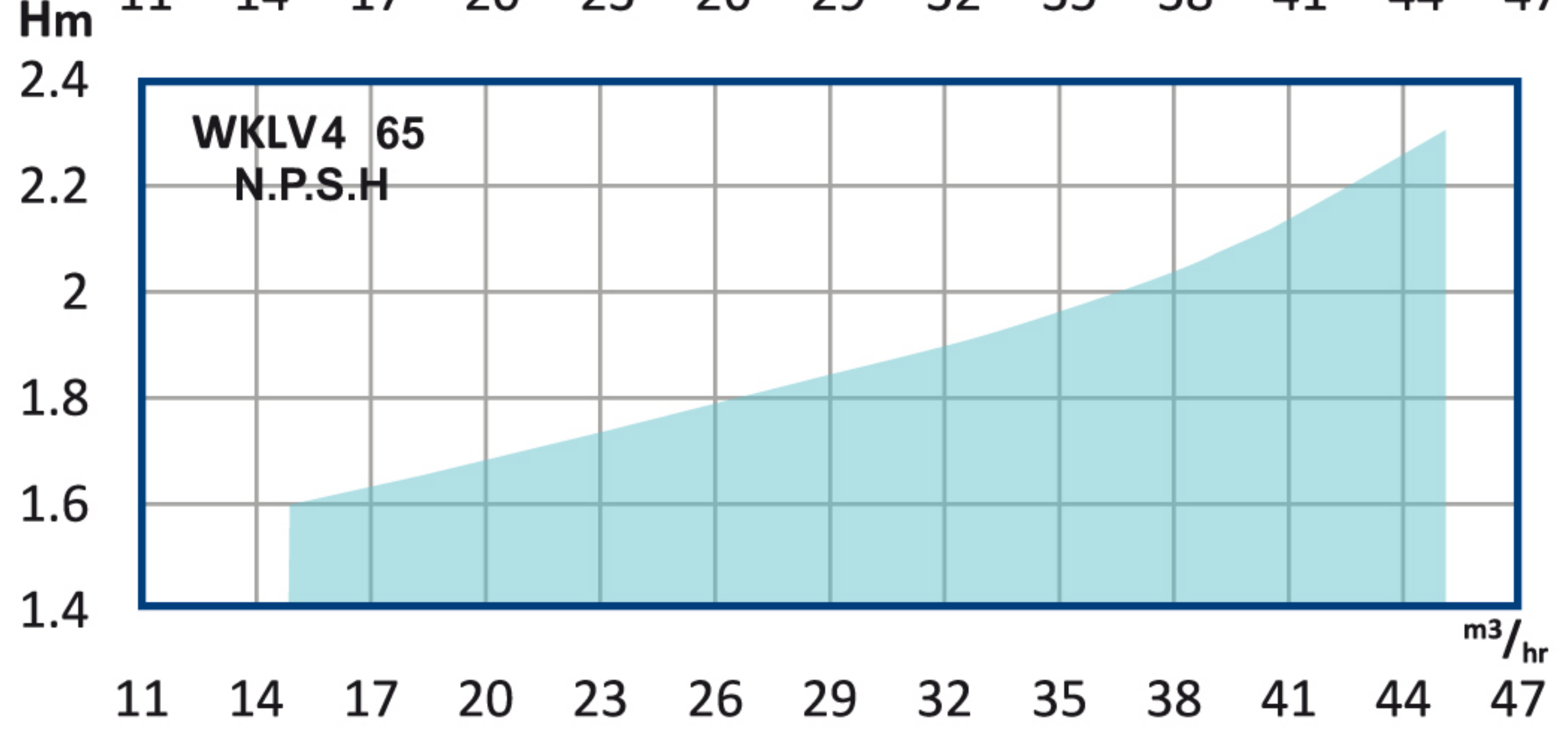
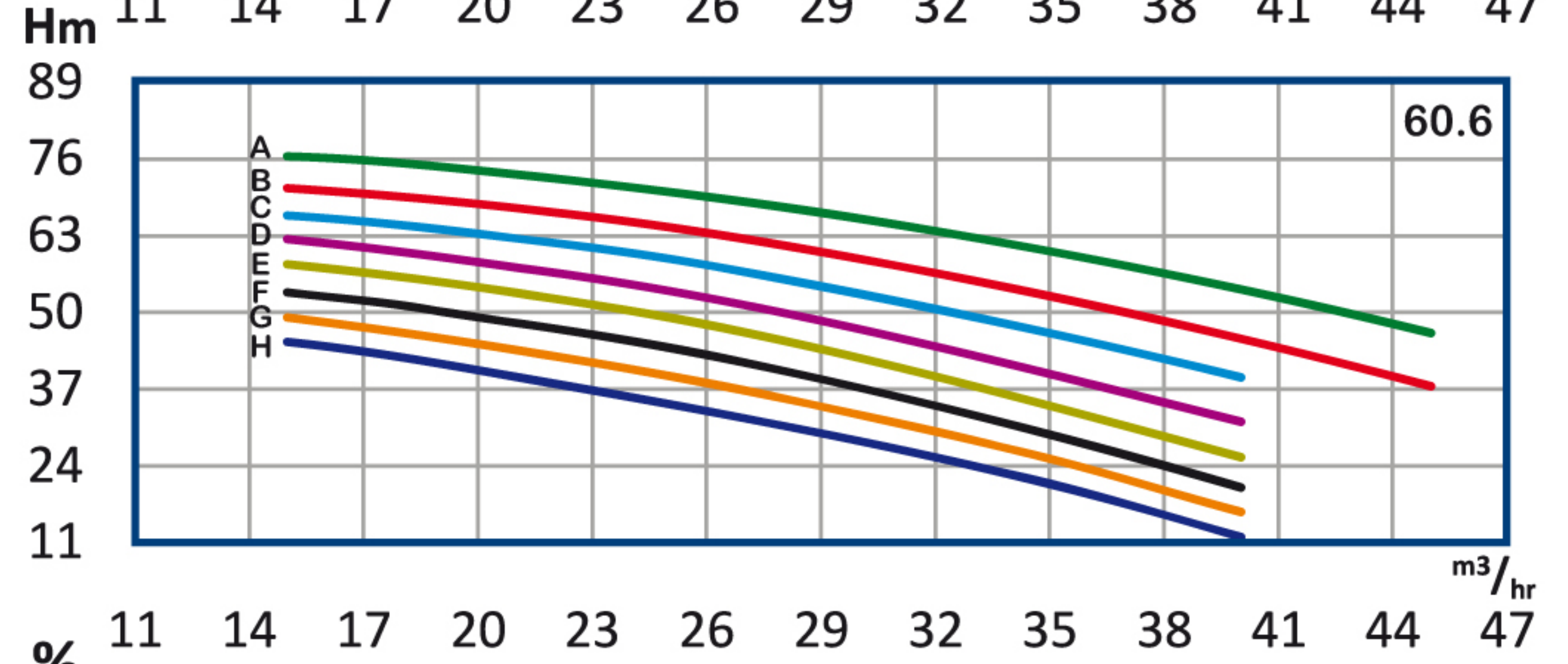
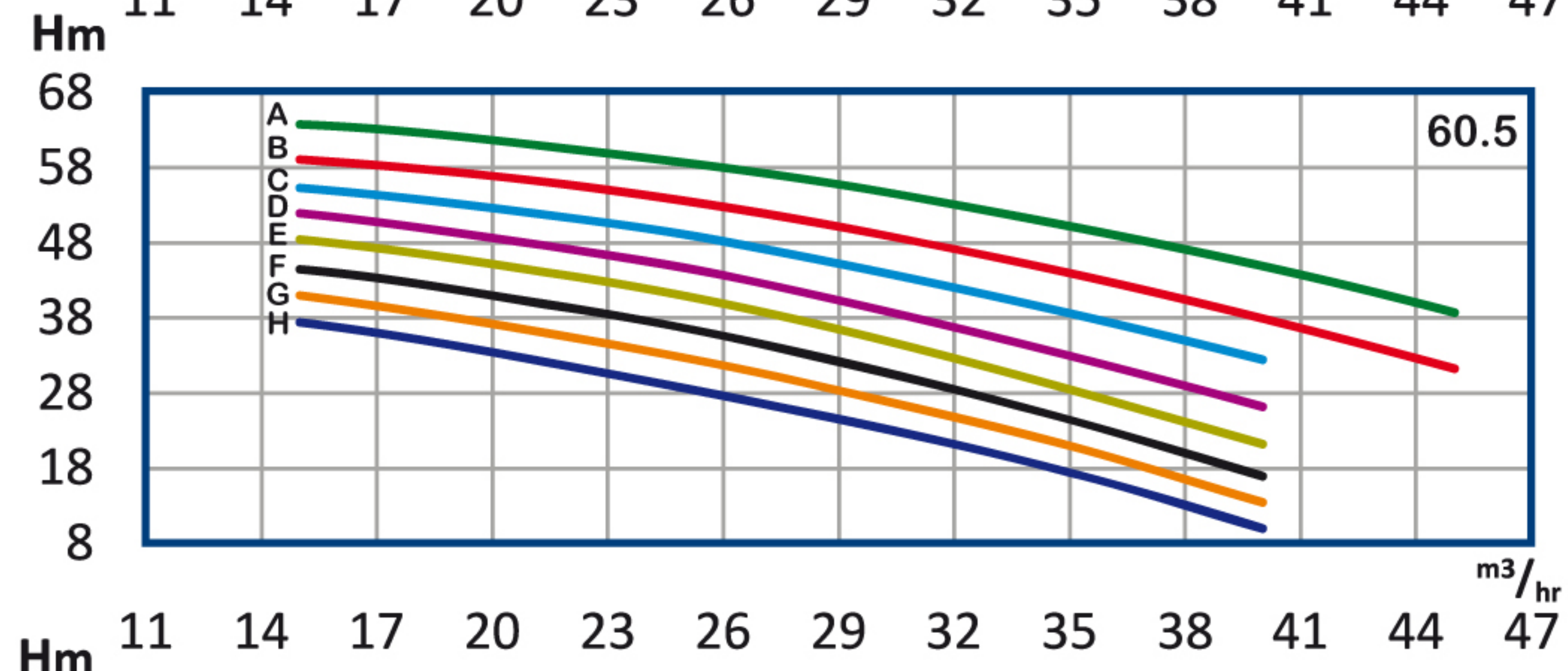
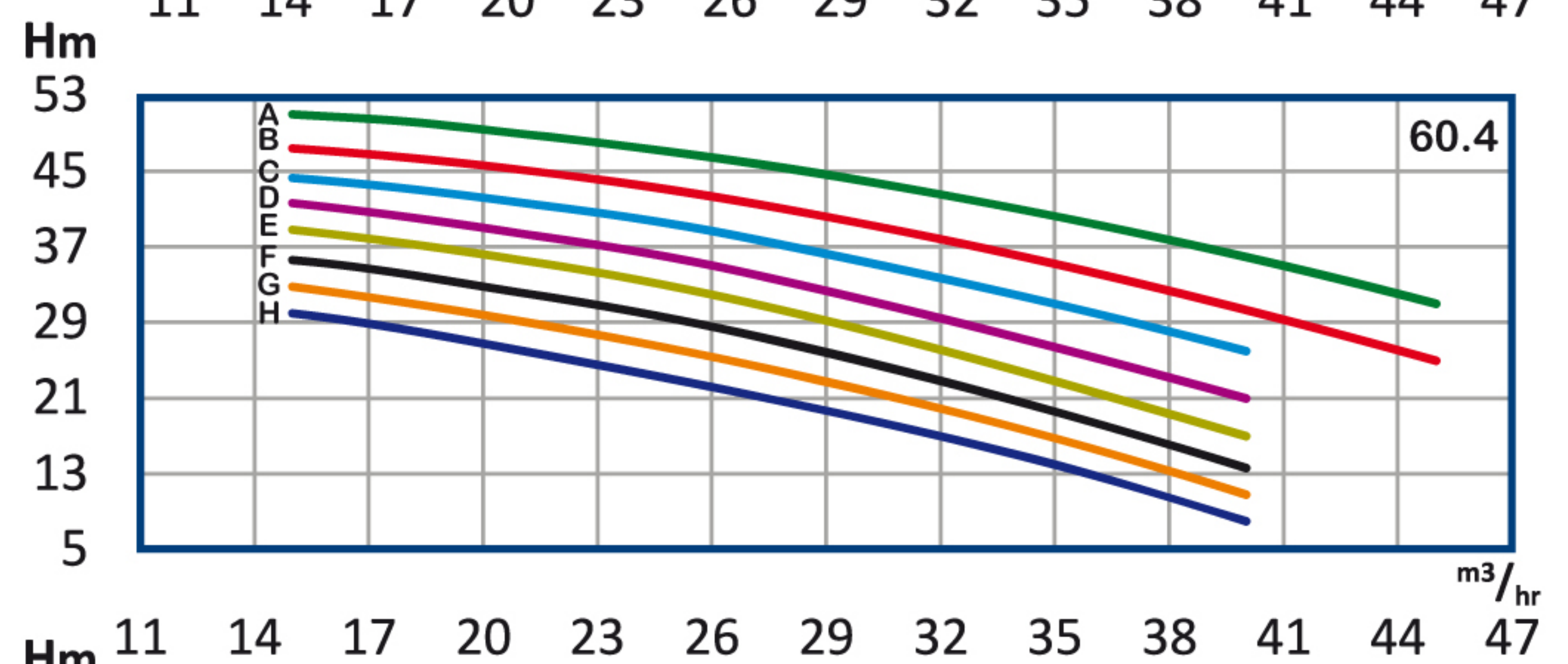
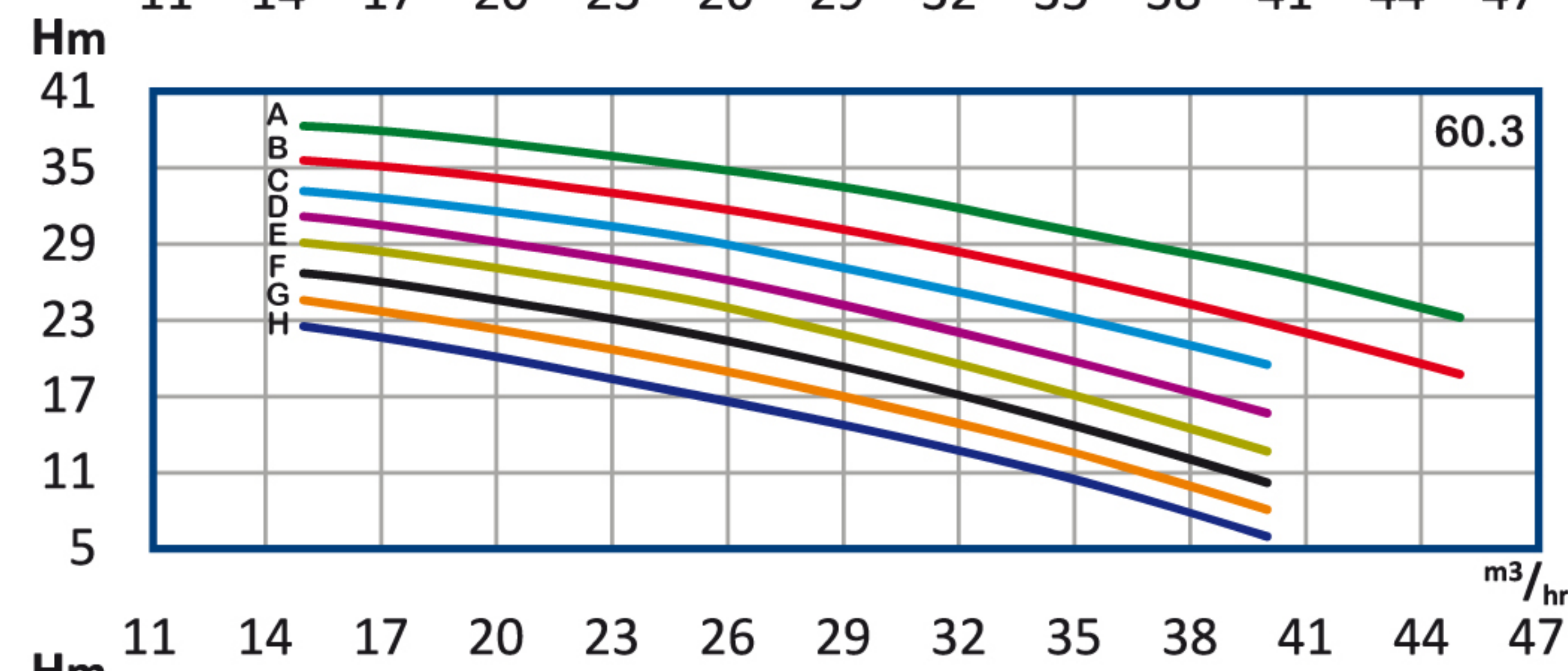
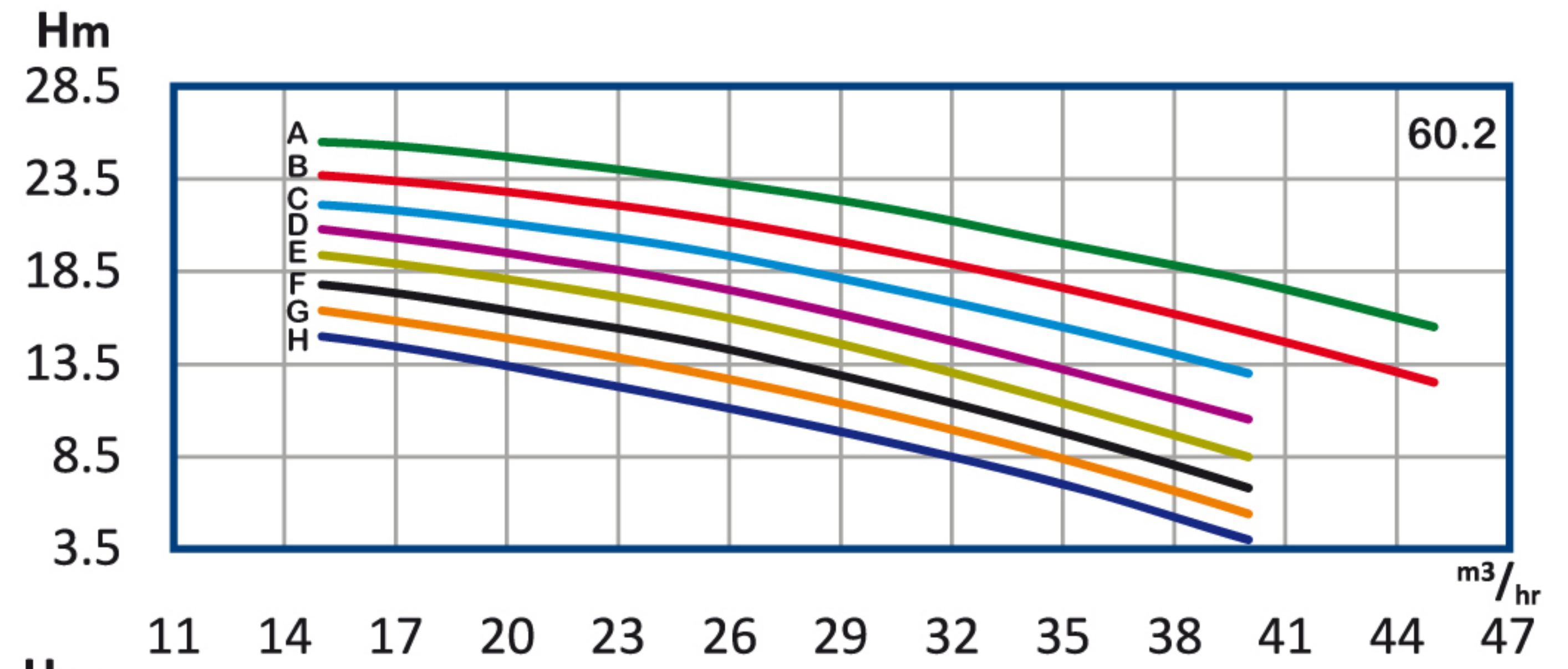
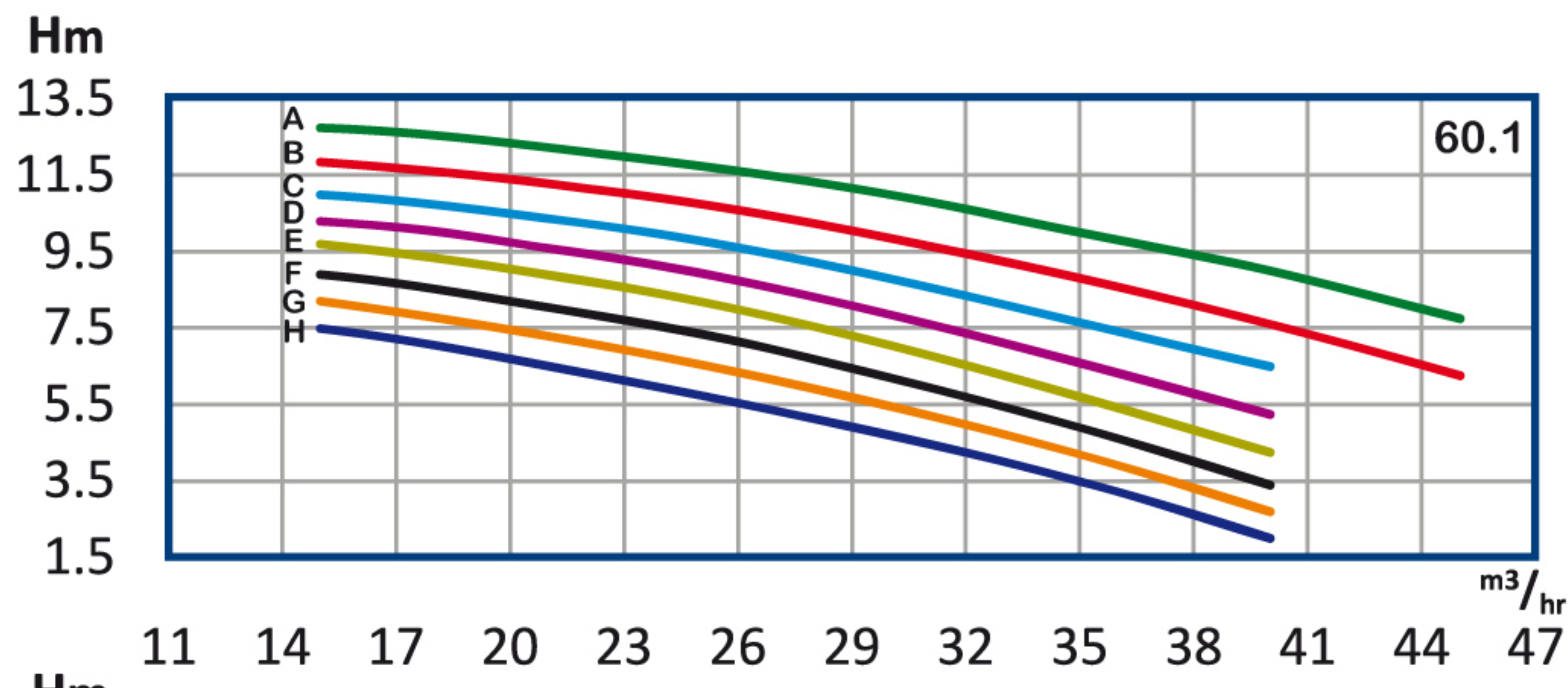

n ≈ 1450 rpm

پمپ 65 WKLV4, WKL 4

تیپ پمپ	توان P		آمپر A	قطر پروانه D (mm)	قطر فلنج mm		Q								
	KW	HP			مکش	رانس	آبدهی								
							m <sup>3</sup> /h	15	17.5	20	25	30	35	40	45
WKLV4 65.7 H	5.5	7.5	12	155				52.5	50.05	47	40.2	33	24.5	14	*
WKLV4 65.7 G	5.5	7.5	12	160				57.4	55	52	45.8	38	29.4	19	*
WKLV4 65.7 F	7.5	10	16	165				62.3	60.2	57.4	51.4	43.4	34.3	23.8	*
WKLV4 65.7 E	7.5	10	16	170				68	65.8	63.3	57.4	49.3	40	29.7	*
WKLV4 65.7 D	7.5	10	16	175				72.8	70.7	68.2	62.6	55	46.2	36.7	*
WKLV4 65.7 C	11	15	22	180				77.3	76	73.8	69	62	54.2	45.5	*
WKLV4 65.7 B	11	15	22	185				83	81.5	79.8	75.2	69	61.6	53.2	43.7
WKLV4 65.7 A	15	20	29	192				89.2	88.2	86.4	82.2	77	70.3	63	54.2
WKLV4 65.8 H	7.5	10	16	155				60	57.2	53.6	46	37.6	28	16	*
WKLV4 65.8 G	7.5	10	16	160				65.6	62.8	59.6	52.4	43.6	33.6	21.6	*
WKLV4 65.8 F	7.5	10	16	165				71.2	68.8	65.6	58.8	49.6	39.2	27.2	*
WKLV4 65.8 E	11	15	22	170				77.6	75.2	72.4	65.6	56.4	45.6	34	*
WKLV4 65.8 D	11	15	22	175				83.2	80.8	78	71.6	62.8	52.8	42	*
WKLV4 65.8 C	11	15	22	180				88.5	86.8	84.4	78.8	70.8	62	52	*
WKLV4 65.8 B	15	20	30	185				94.8	93.2	91.2	86	78.8	70.4	60.8	50
WKLV4 65.8 A	15	20	30	192				102	100.8	98.8	94	88	80.4	72	62
WKLV4 65.9 H	7.5	10	16	155				67.5	64.3	60.3	51.7	42.3	31.5	18	*
WKLV4 65.9 G	7.5	10	16	160				73.8	70.6	67	59	49	37.8	24.3	*
WKLV4 65.9 F	7.5	10	16	165				80	77.4	73.8	66	55.8	44	30.6	*
WKLV4 65.9 E	11	15	22	170				87.3	84.6	81.4	73.8	63.4	51.3	38.2	*
WKLV4 65.9 D	11	15	22	175				93.6	91	87.7	80.5	70.6	59.4	47.2	*
WKLV4 65.9 C	11	15	22	180				99.6	97.6	95	88.6	79.6	69.7	58.5	*
WKLV4 65.9 B	15	20	30	185				106.7	105	102.6	96.7	88.6	79.2	68.4	56.2
WKLV4 65.9 A	18.5	25	38	192				114.8	113.4	111.2	105.8	99	90.4	81	69.7
WKLV4 65.10 H	7.5	10	16	155	80	65	H (m)	75	71.5	67	57.5	47	35	20	*
WKLV4 65.10 G	7.5	10	16	160				82	78.5	74.5	65.5	54.5	42	27	*
WKLV4 65.10 F	11	15	22	165				89	86	82	73.5	62	49	34	*
WKLV4 65.10 E	11	15	22	170				97	94	90.5	82	70.5	57	42.5	*
WKLV4 65.10 D	11	15	22	175				104	101	97.5	89.5	78.5	66	52.5	*
WKLV4 65.10 C	15	20	30	180				110.7	108.5	105.5	98.5	88.5	77.5	65	*
WKLV4 65.10 B	15	20	30	185				118.5	116.5	114	107.5	98.5	88	76	62.5
WKLV4 65.10 A	18.5	25	38	192				127.5	126	123.5	117.5	110	100.5	90	77.5
WKLV4 65.11 H	7.5	10	16	155				82.5	78.6	73.7	63.2	51.7	38.5	22	*
WKLV4 65.11 G	11	15	22	160				90.2	86.3	82	72	60	46.2	29.7	*
WKLV4 65.11 F	11	15	22	165				98	94.6	90.2	80.8	68.2	54	37.4	*
WKLV4 65.11 E	11	15	22	170				106.7	103.4	99.5	90.2	77.5	62.7	46.7	*
WKLV4 65.11 D	15	20	30	175				114.4	111	107.3	98.4	86.3	72.6	57.7	*
WKLV4 65.11 C	15	20	30	180				122	119.4	116	108.4	97.3	85.2	71.5	*
WKLV4 65.11 B	15	20	30	185				130.4	128.2	125.4	118.3	108.4	96.8	83.6	68.7
WKLV4 65.11 A	18.5	25	38	192				140.3	138.6	136	129.3	121	110.6	99	85.2
WKLV4 65.12 H	11	15	22	155				90	85.8	80.4	69	56.4	42	24	*
WKLV4 65.12 G	11	15	22	160				98.4	94.2	89.4	78.6	65.4	50.4	32.4	*
WKLV4 65.12 F	11	15	22	165				106.8	103.2	98.4	88.2	74.4	58.8	40.8	*
WKLV4 65.12 E	15	20	30	170				116.4	112.8	108.6	98.4	84.6	68.4	51	*
WKLV4 65.12 D	15	20	30	175				124.8	121.2	117	107.4	94.2	79.2	63	*
WKLV4 65.12 C	15	20	30	180				133	130.2	126.6	118.2	106.2	93	78	*
WKLV4 65.12 B	18.5	25	38	185				142.2	139.8	136.8	129	118.2	105.6	91.2	75
WKLV4 65.12 A	22	30	43.5	192				153	151.2	148.2	141	132	120.6	108	93

H	m	13.7	23	32	41	53	66	81	96	111	126	142	158
	ft	45	75	105	135	175	215	265	315	365	415	465	520

Q	m <sup>3</sup> /h	15	17.5	20	25	30	35	40	45
	g.p.m	57	66	76	95	114	132	151	170

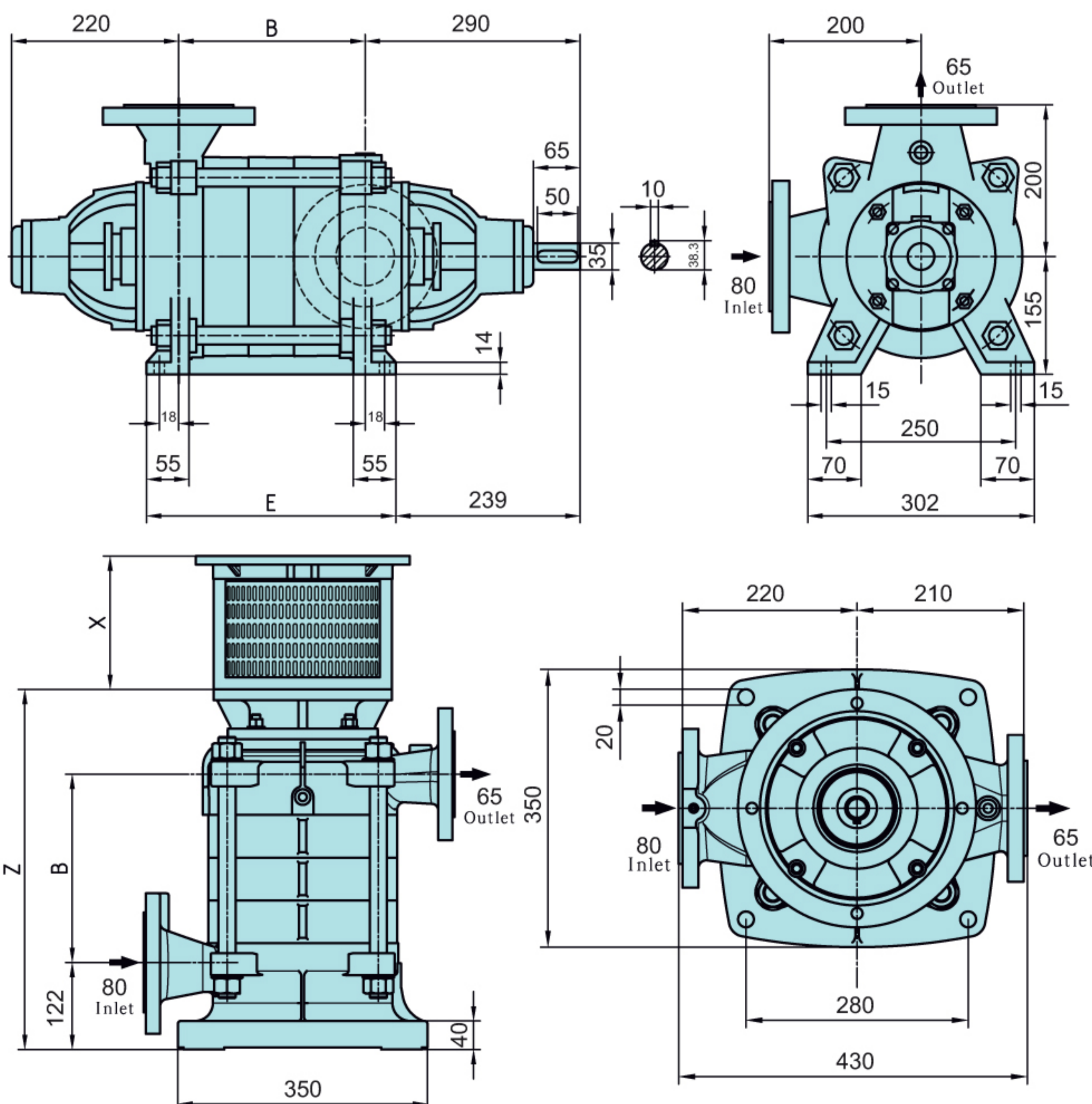
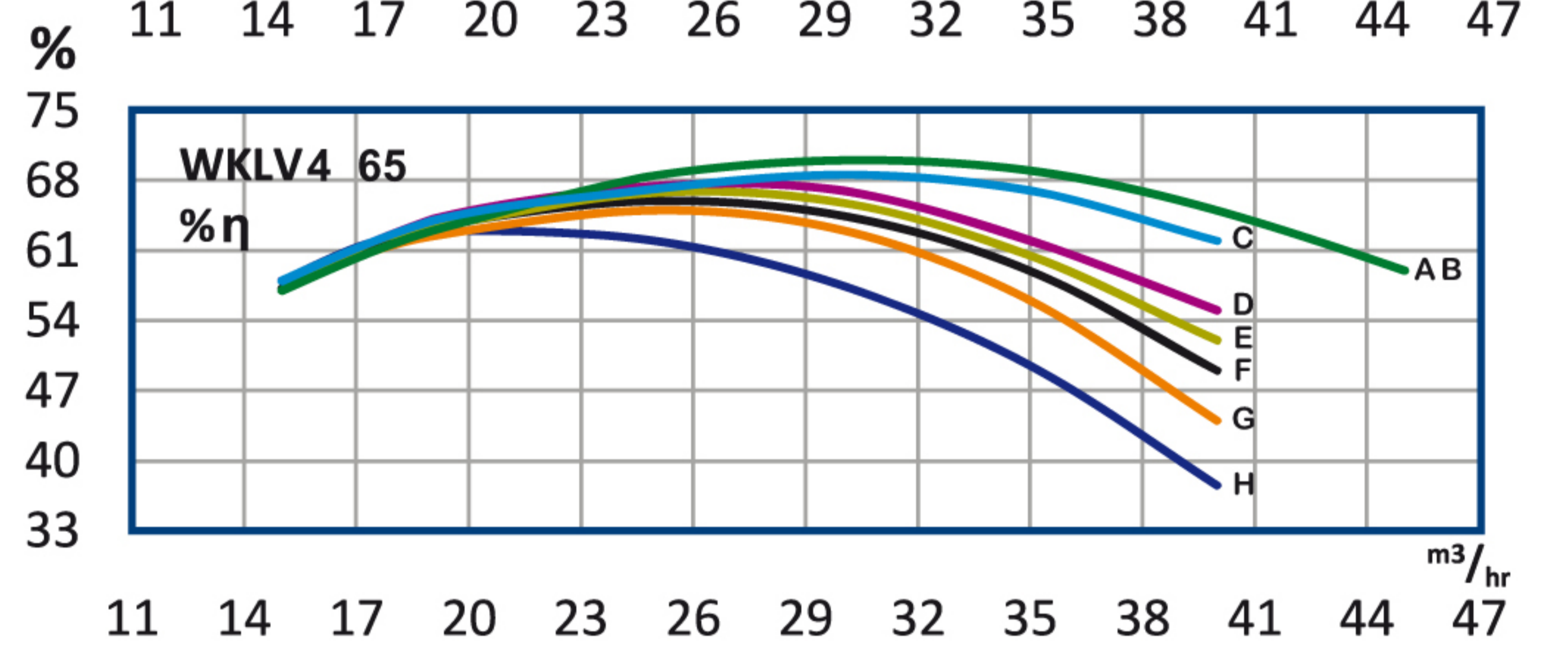
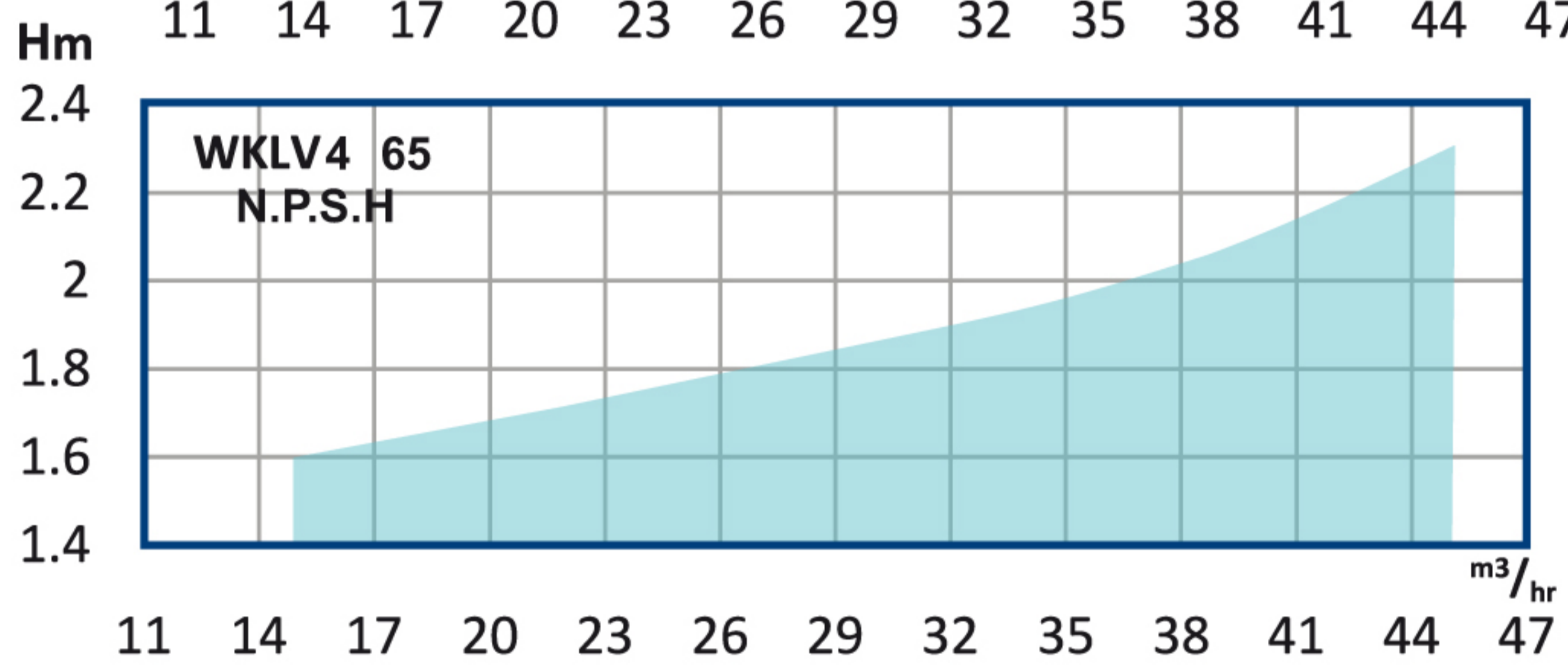
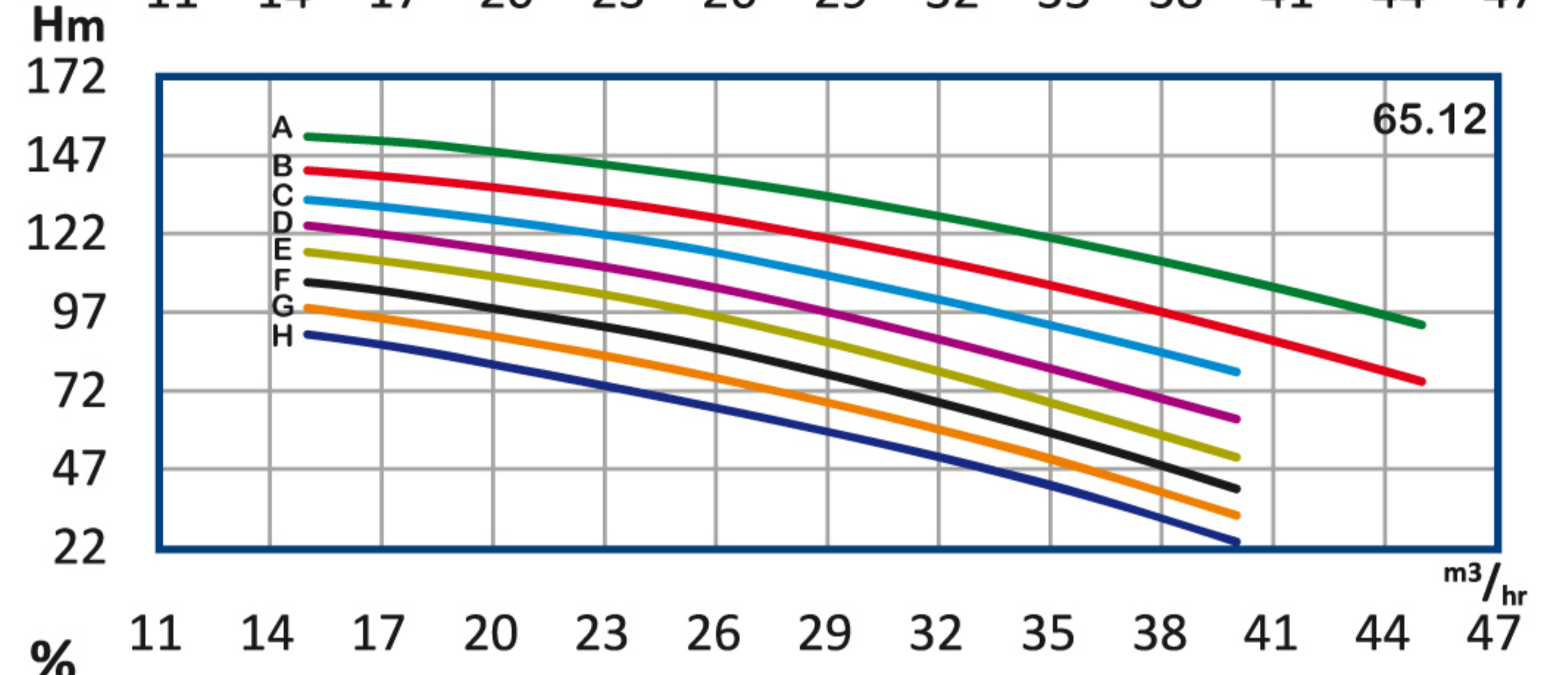
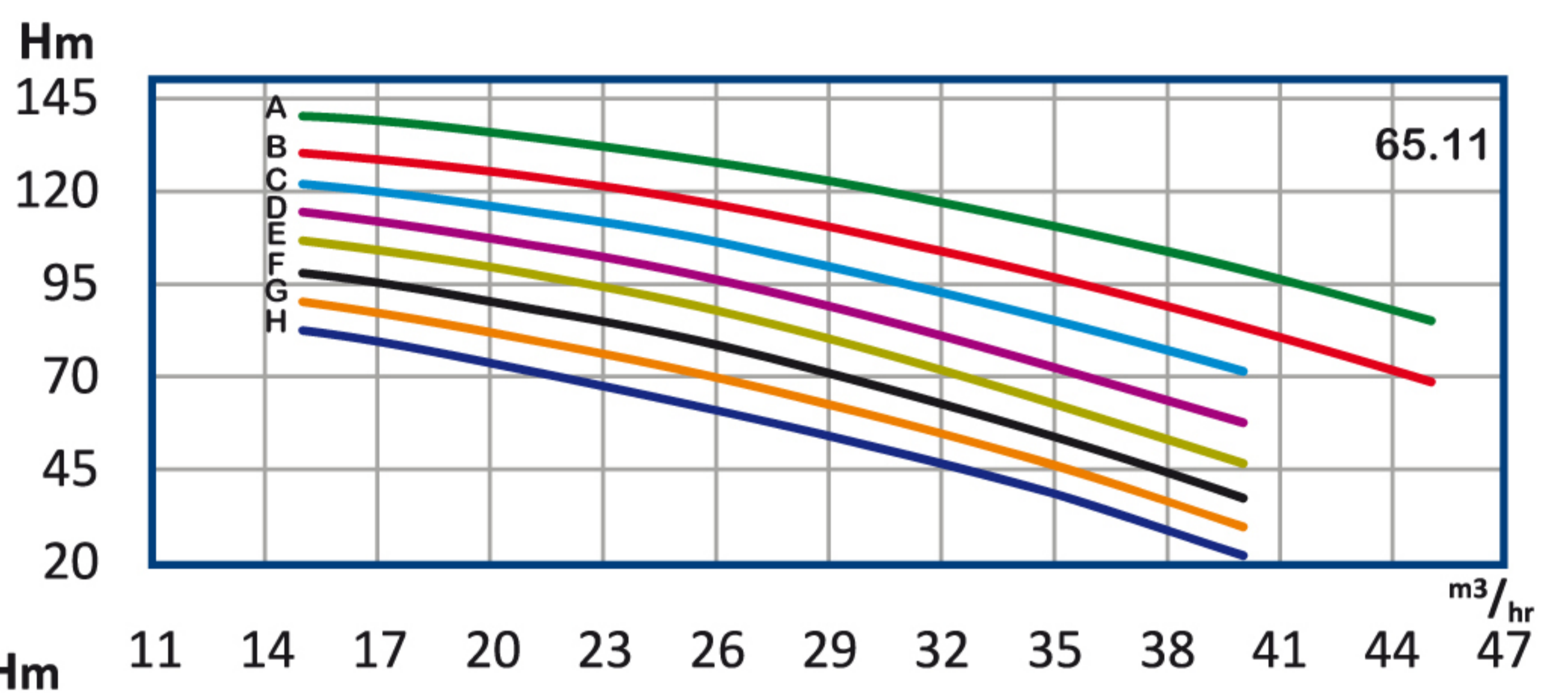
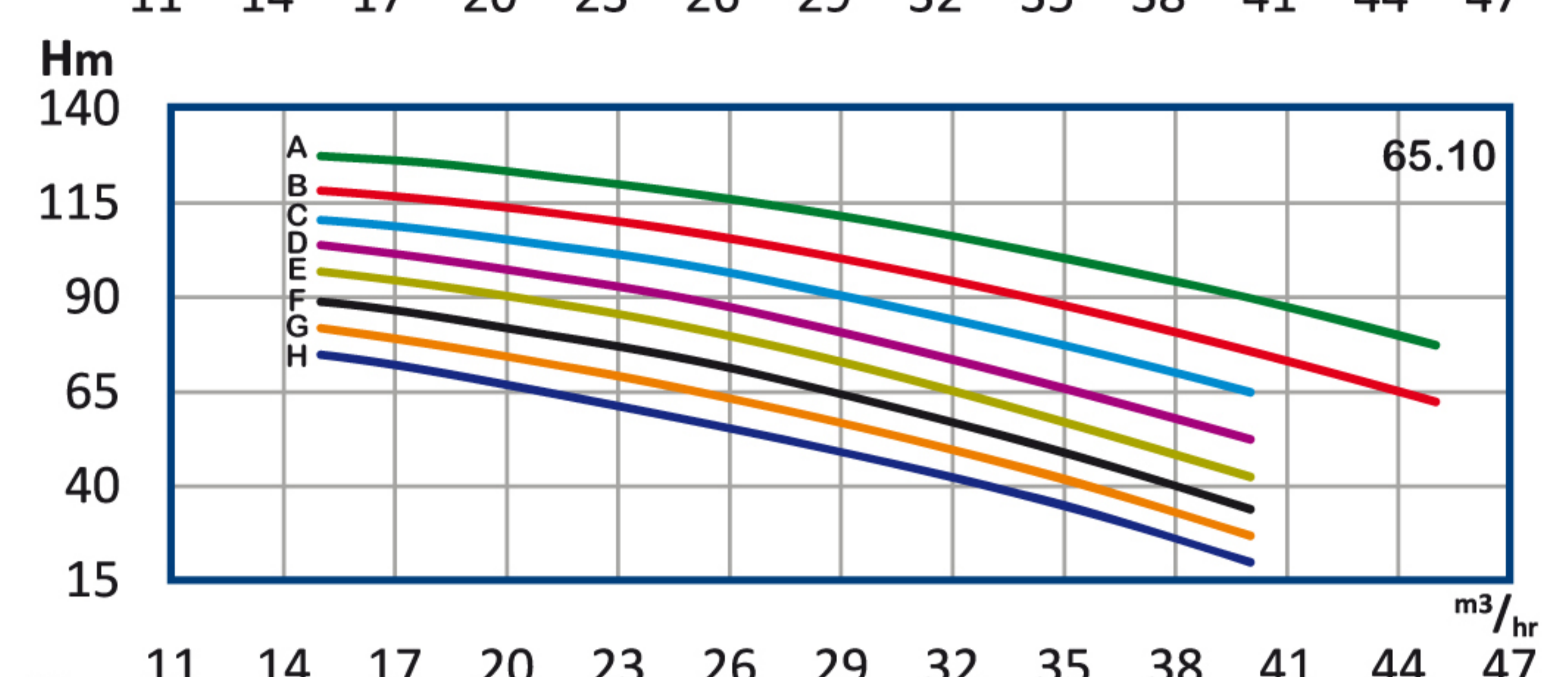
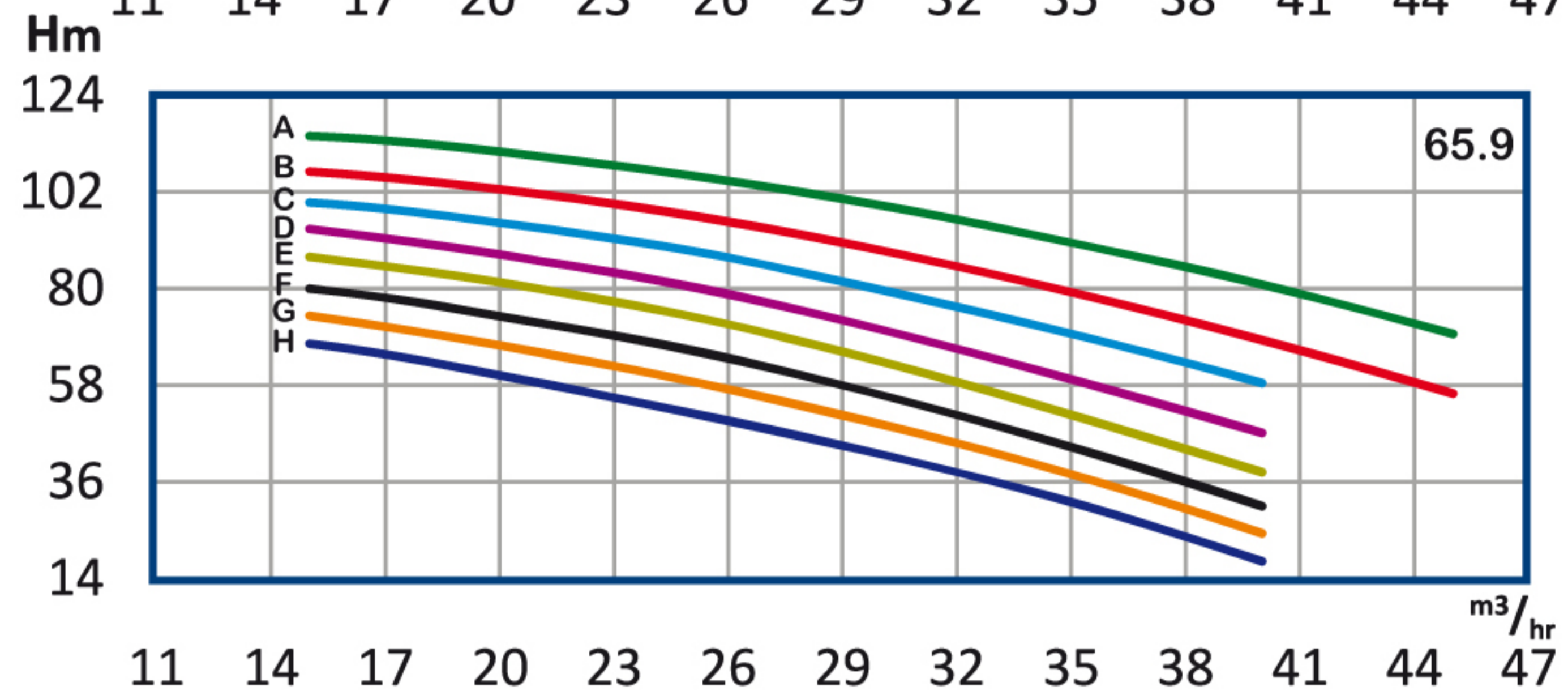
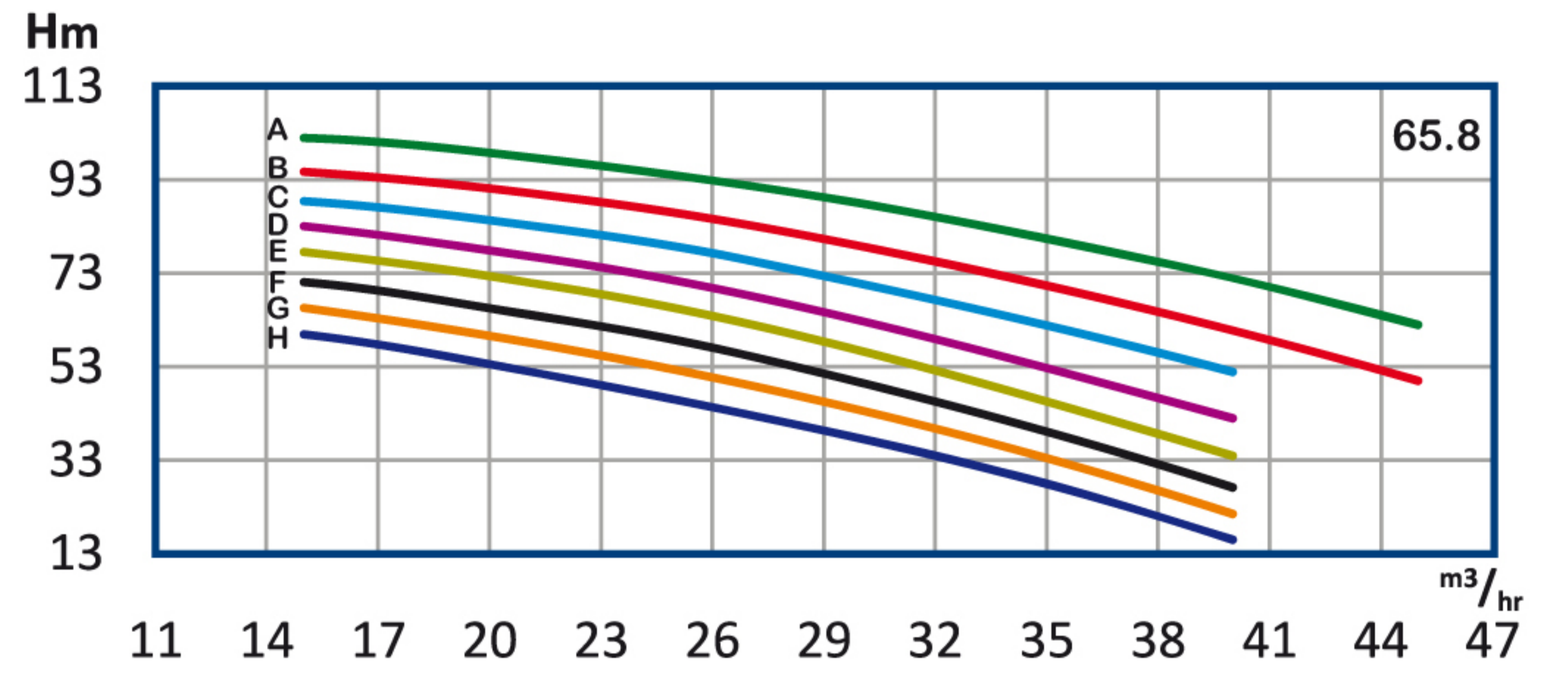
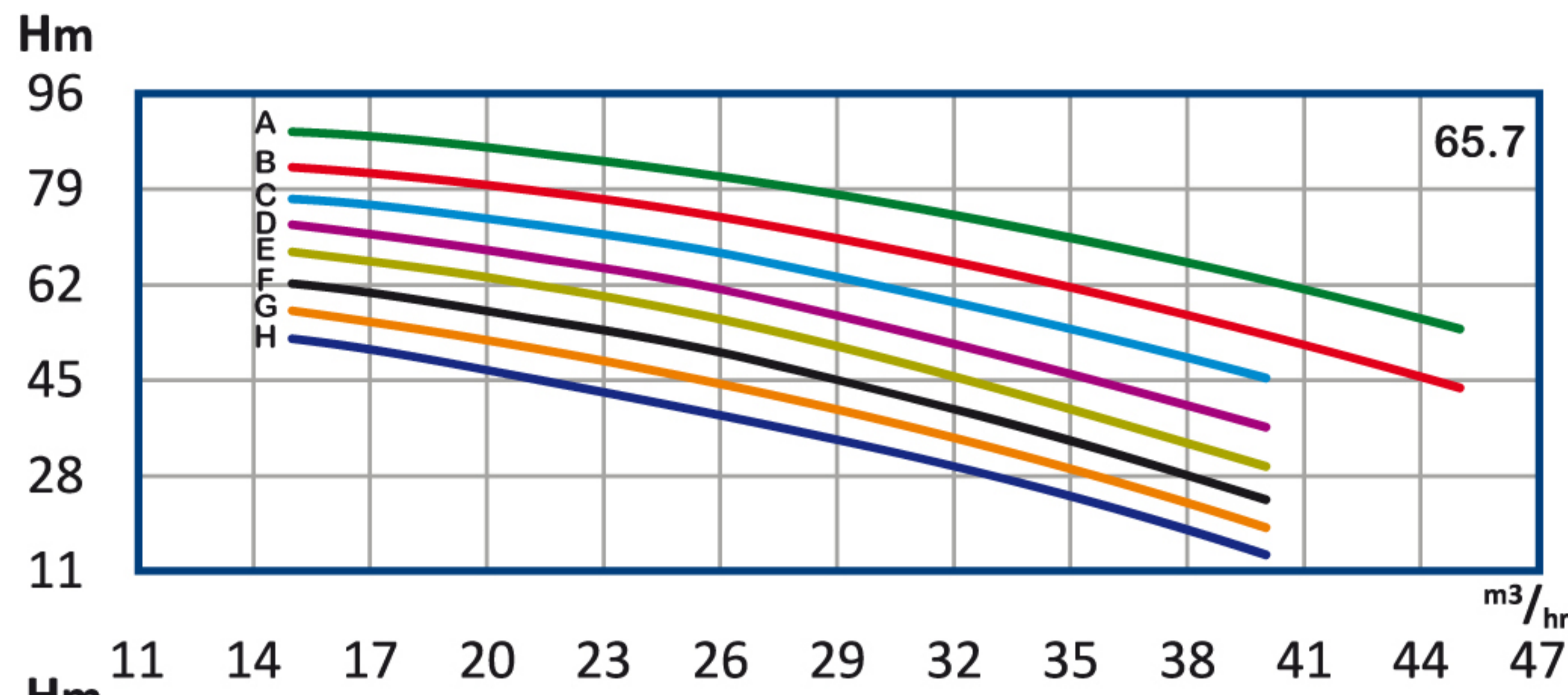

**جدول طول پمپ WKL4 65 (mm)**

تعداد طبقه	B	E	تعداد طبقه	B	E
1	87	289	7	447	549
2	147	249	8	507	609
3	207	309	9	567	669
4	267	369	10	627	729
5	327	429	11	687	789
6	387	489	12	747	849

**جدول طول پمپ WKL4 65 (mm)**

تعداد طبقه	B	Z	تعداد طبقه	B	Z
1	84	325	7	444	685
2	144	385	8	504	745
3	204	445	9	564	805
4	264	505	10	624	865
5	324	565	11	684	925
6	384	625	12	744	985

X: متناسب با قدرت الکترو موتور تغییر می یابد.

n≈ 2900 rpm

پمپ WKL 65 , WKL V

تیپ پمپ	توان P		آمپر A	قطر پروانه D (mm)	قطر فلنج mm		Q آبدھی								
	KW	HP			مکش	رانس	m <sup>3</sup> /h	20	30	40	45	50	60	70	80
							l/s	5.56	8.34	11.1	12.5	13.9	16.7	19.5	22.3
WKL V 65.1 H	7.5	10	15	155	80	65	H (m)	33	31	27.5	25.5	23.5	18.5	13	*
WKL V 65.1 G	7.5	10	15	160				36	34	30.8	28.8	26.8	21.7	16	*
WKL V 65.1 F	7.5	10	15	165				38.8	36.8	33.8	32	29.8	24.5	19	*
WKL V 65.1 E	7.5	10	15	170				41	39.4	36.8	35	33	27.6	22	*
WKL V 65.1 D	7.5	10	15	175				44	42.2	39.8	38.3	36.3	31.5	26	*
WKL V 65.1 C	11	15	22.5	180				46	45	42.6	41	39	35	30	*
WKL V 65.1 B	11	15	22.5	185				49	48	46	44.6	43	39	34.8	29.5
WKL V 65.1 A	11	15	22.5	192				53	52	50	48.6	47	43.5	39.3	34.5
WKL V 65.2 H	11	15	22.5	155				66	62	55.5	51.5	47	37	26	*
WKL V 65.2 G	15	20	30	160				72	68	61.6	57.8	53.6	43.4	32	*
WKL V 65.2 F	15	20	30	165				77.6	73.6	68	64.5	60.5	50	39	*
WKL V 65.2 E	15	20	30	170				82	78.8	73.6	70	66	55.2	44	*
WKL V 65.2 D	15	20	30	175				86.5	84	79	76	71.5	62	51	*
WKL V 65.2 C	18.5	25	36	180				92	90	85.2	82.2	78.2	70	60	*
WKL V 65.2 B	22	30	42.5	185				98	96	92	89.2	86	78.2	69.6	60
WKL V 65.2 A	22	30	42.5	192				106	104	100	97.2	94	87	78.6	69
WKL V 65.3 H	18.5	25	36	155				99	93	83	77	70.5	55.5	39	*
WKL V 65.3 G	18.5	25	36	160				108	102	92.4	86.7	80.4	65	48	*
WKL V 65.3 F	22	30	42.5	165				116	110	102	96.8	90.8	75	58.5	*
WKL V 65.3 E	22	30	42.5	170				123	118	110	105	99	82.8	66	*
WKL V 65.3 D	30	40	57	175				131	126	119	114	107	93	76.5	*
WKL V 65.3 C	30	40	57	180				139	135	128	123	117	105	90	*
WKL V 65.3 B	30	40	57	185				148	144	138	134	129	117	104	88.5
WKL V 65.3 A	37	50	69	192				159	156	150	146	141	131	118	104

H	m	12	24	37	49	61	76	91	107	122	137	152	168
	ft	40	80	120	160	200	250	300	350	400	450	500	550

Q	m <sup>3</sup> /h	20	30	40	45	50	60	70	80
	g.p.m	76	114	152	170	190	227	265	303

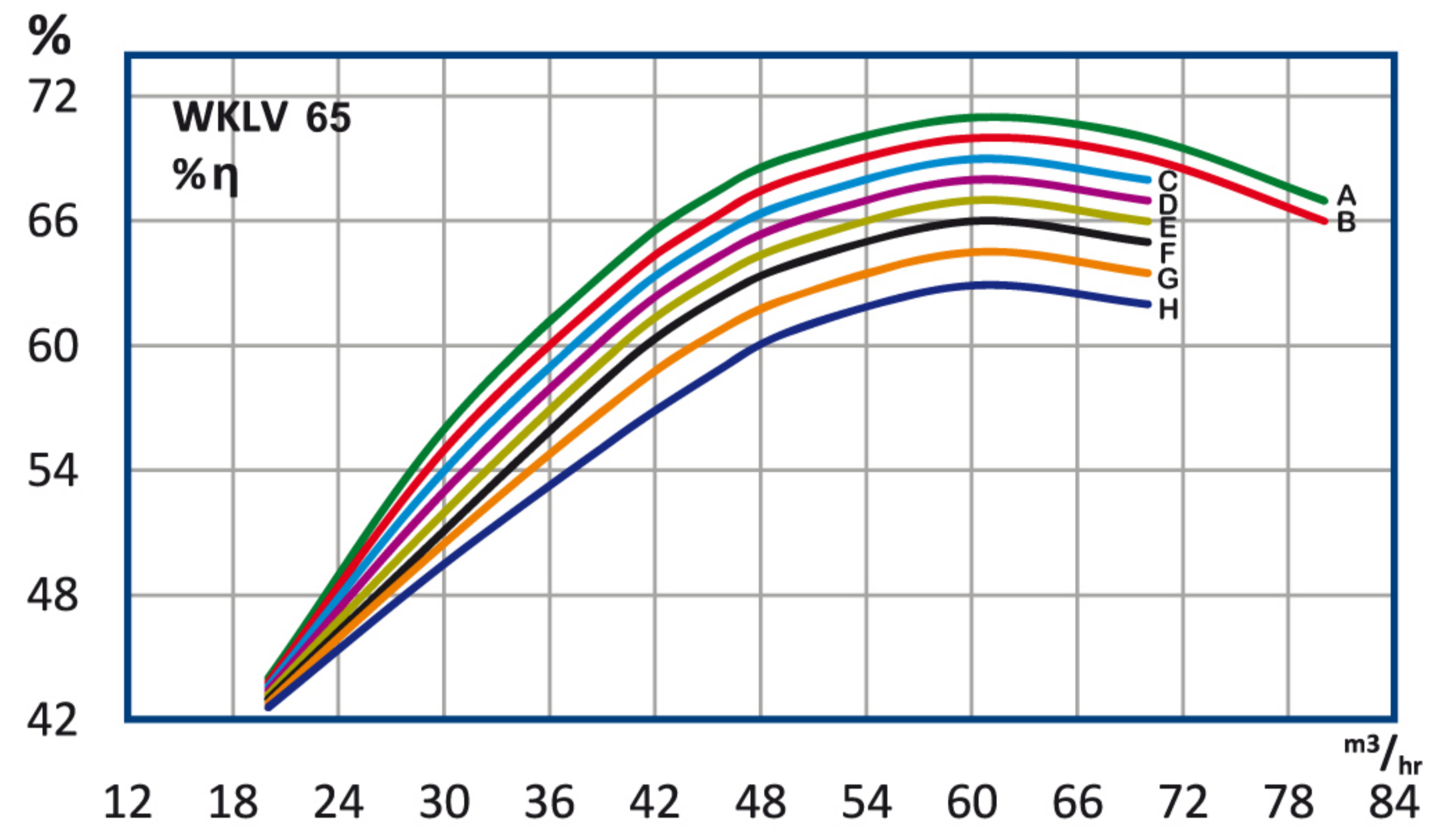
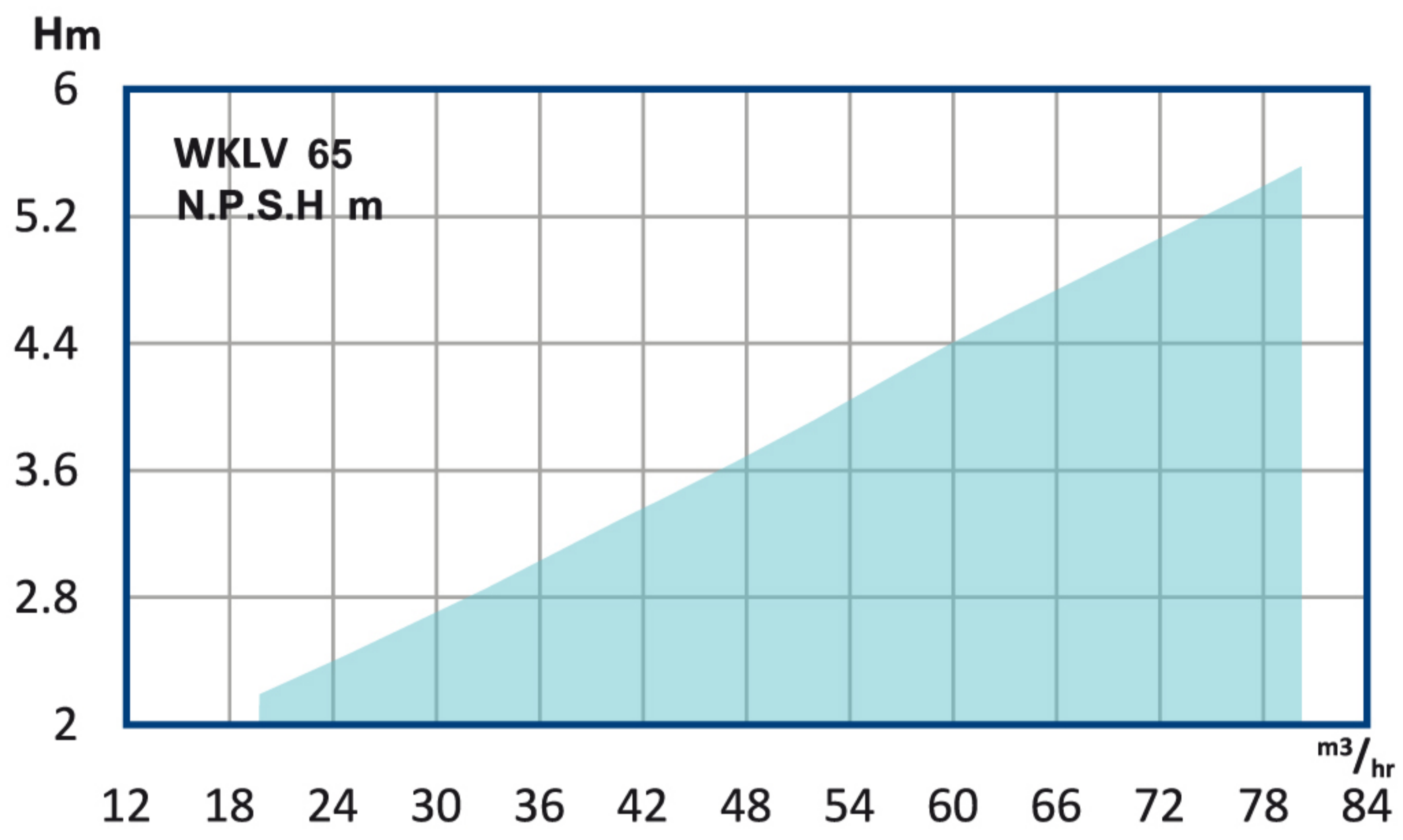
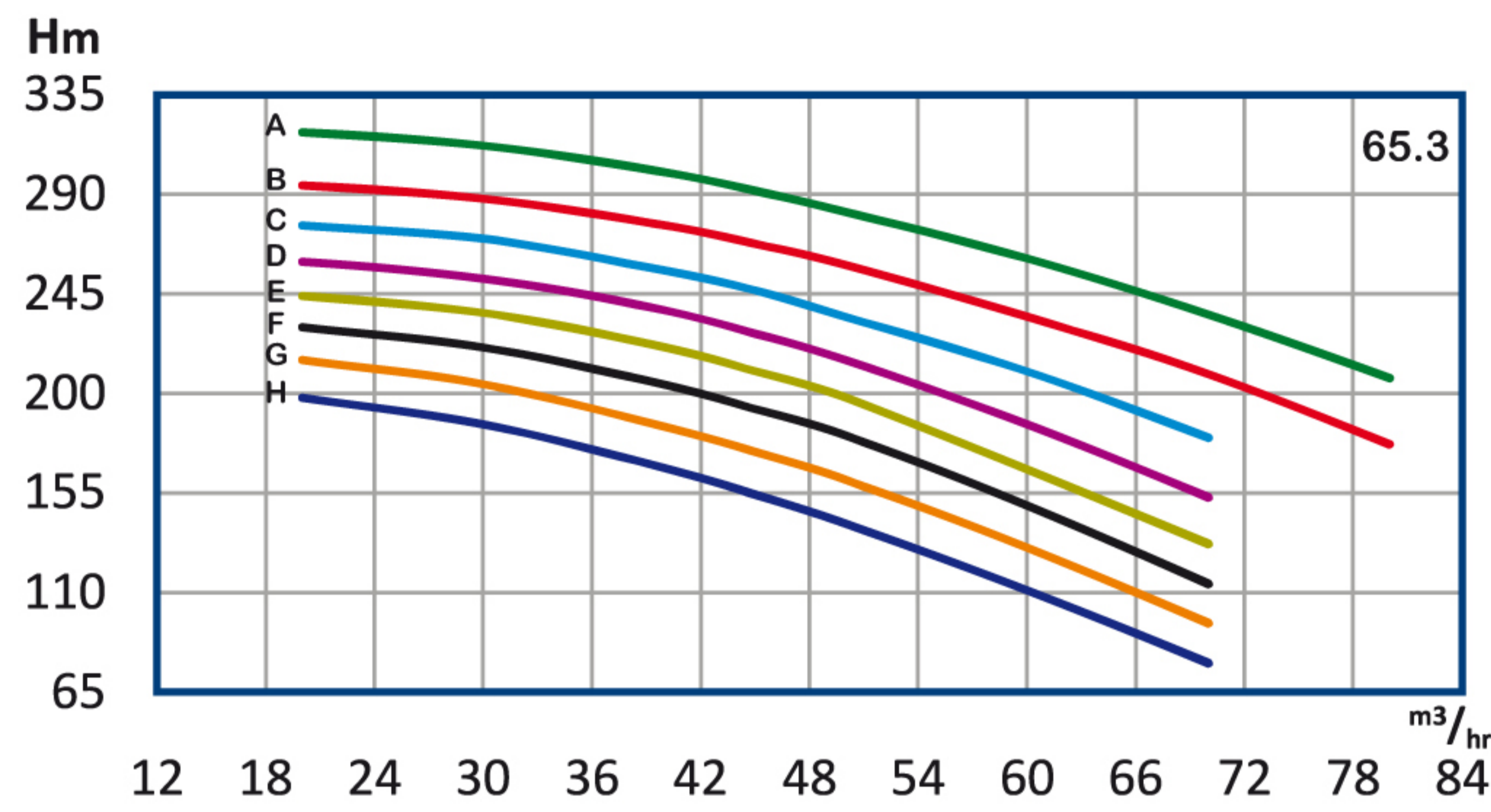
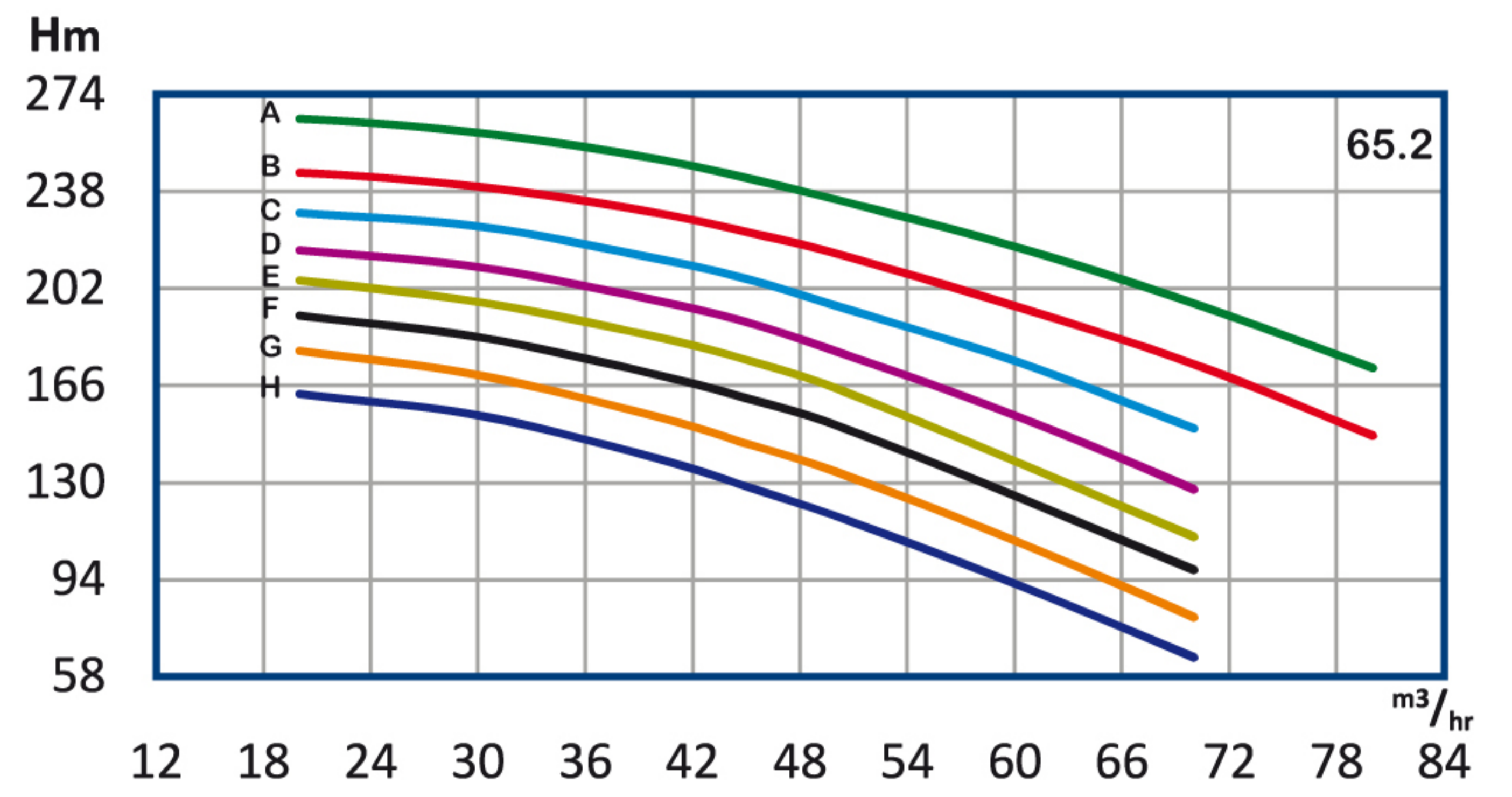
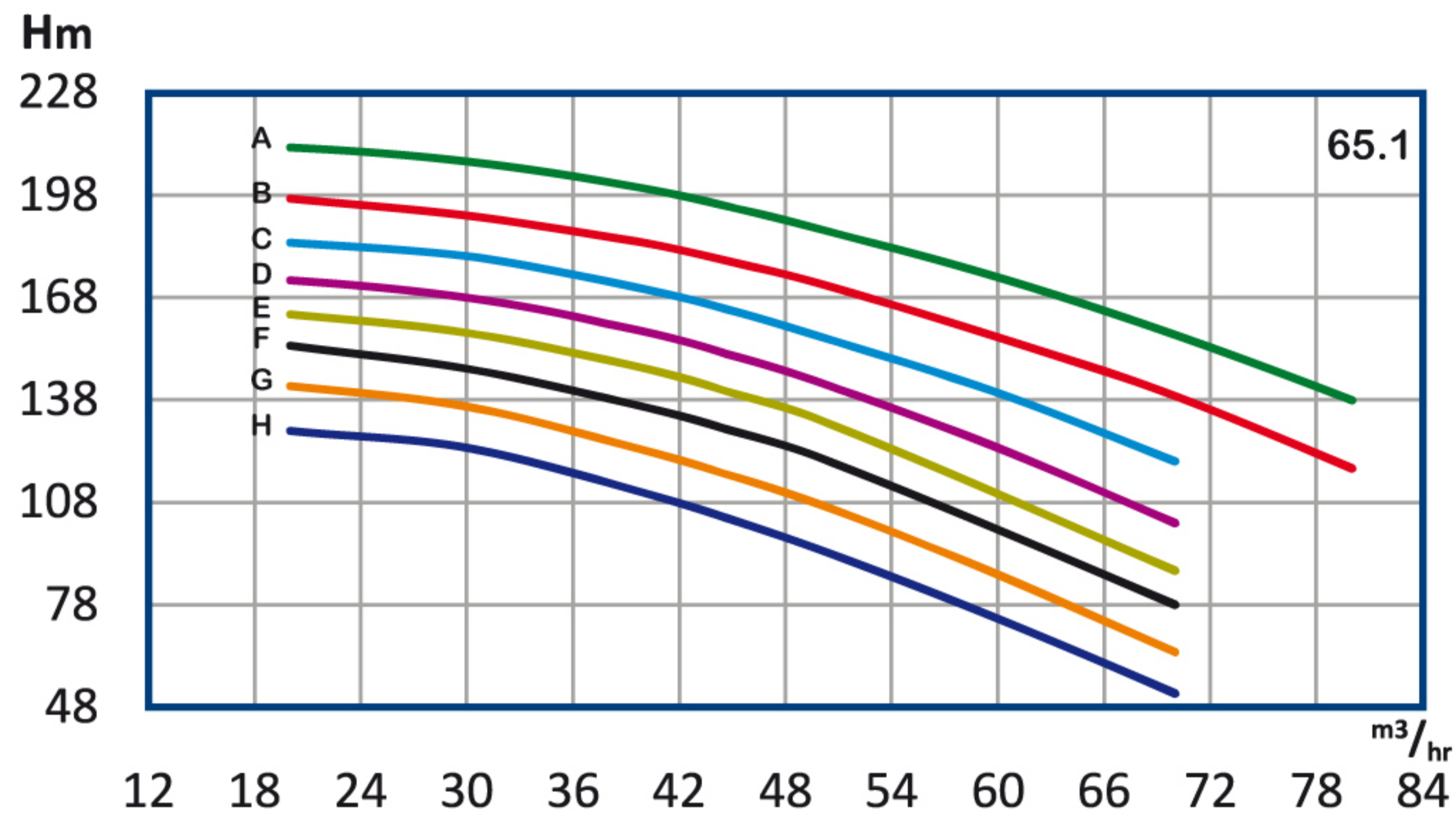

n≈ 2900 rpm

پمپ WKL 65 , WKL V

تیپ پمپ	توان P		آمپر A	قطر پروانه D (mm)	قطر فلنج mm		Q آبدھی								
	KW	HP			مکش	رانس	m3/h	H (m)							
								20	30	40	45	50	60	70	80
WKL V 65.4 H	22	30	42.5	155	80	65	H (m)	5.56	8.34	11.1	12.5	13.9	16.7	19.5	22.3
WKL V 65.4 G	30	40	57	160				129	124	111	103	94	74	52	*
WKL V 65.4 F	30	40	57	165				142	136	123	116	107	86.8	64	*
WKL V 65.4 E	30	40	57	170				154	147	136	129	121	100	78	*
WKL V 65.4 D	37	50	69	175				163	158	147	140	132	110	88	*
WKL V 65.4 C	37	50	69	180				173	168	158	151	143	124	102	*
WKL V 65.4 B	45	60	83	185				184	180	170	164	156	140	120	*
WKL V 65.4 A	45	60	83	192				196	192	184	178	172	156	139	118
WKL V 65.5 H	30	40	57	155				212	208	200	194	188	174	157	138
WKL V 65.5 G	30	40	57	160				163	155	139	129	118	92.5	65	*
WKL V 65.5 F	37	50	69	165				179	170	155	145	134	109	80	*
WKL V 65.5 E	37	50	69	170				192	184	170	161	151	125	97.5	*
WKL V 65.5 D	37	50	69	175				205	197	184	176	165	138	110	*
WKL V 65.5 C	45	60	83	180				216	210	198	190	179	155	128	*
WKL V 65.5 B	55	75	104	185				230	225	213	206	196	175	150	*
WKL V 65.5 A	55	75	104	192				245	240	230	223	215	196	174	148
WKL V 65.6 H	37	50	69	155				265	260	250	243	235	218	197	173
WKL V 65.6 G	37	50	69	160				198	186	166	154	141	111	78	*
WKL V 65.6 F	45	60	83	165				215	204	185	173	161	130	96	*
WKL V 65.6 E	45	60	83	170				230	221	204	193	181	150	114	*
WKL V 65.6 D	45	60	83	175				244	236	221	210	198	166	132	*
WKL V 65.6 C	55	75	104	180				260	252	238	227	215	186	153	*
WKL V 65.6 B	60	80	124	185				276	270	256	247	235	210	180	*
WKL V 65.6 A	75	100	140	192				294	288	276	268	258	235	209	177
								318	312	300	292	282	261	236	207

H	m	52	73	94	119	143	168	192	216	241	265	293	320
	ft	170	240	310	390	470	550	630	710	790	870	960	1050

Q	m3 /h	20	30	40	45	50	60	70	80
	g.p.m	76	114	152	170	190	227	265	303

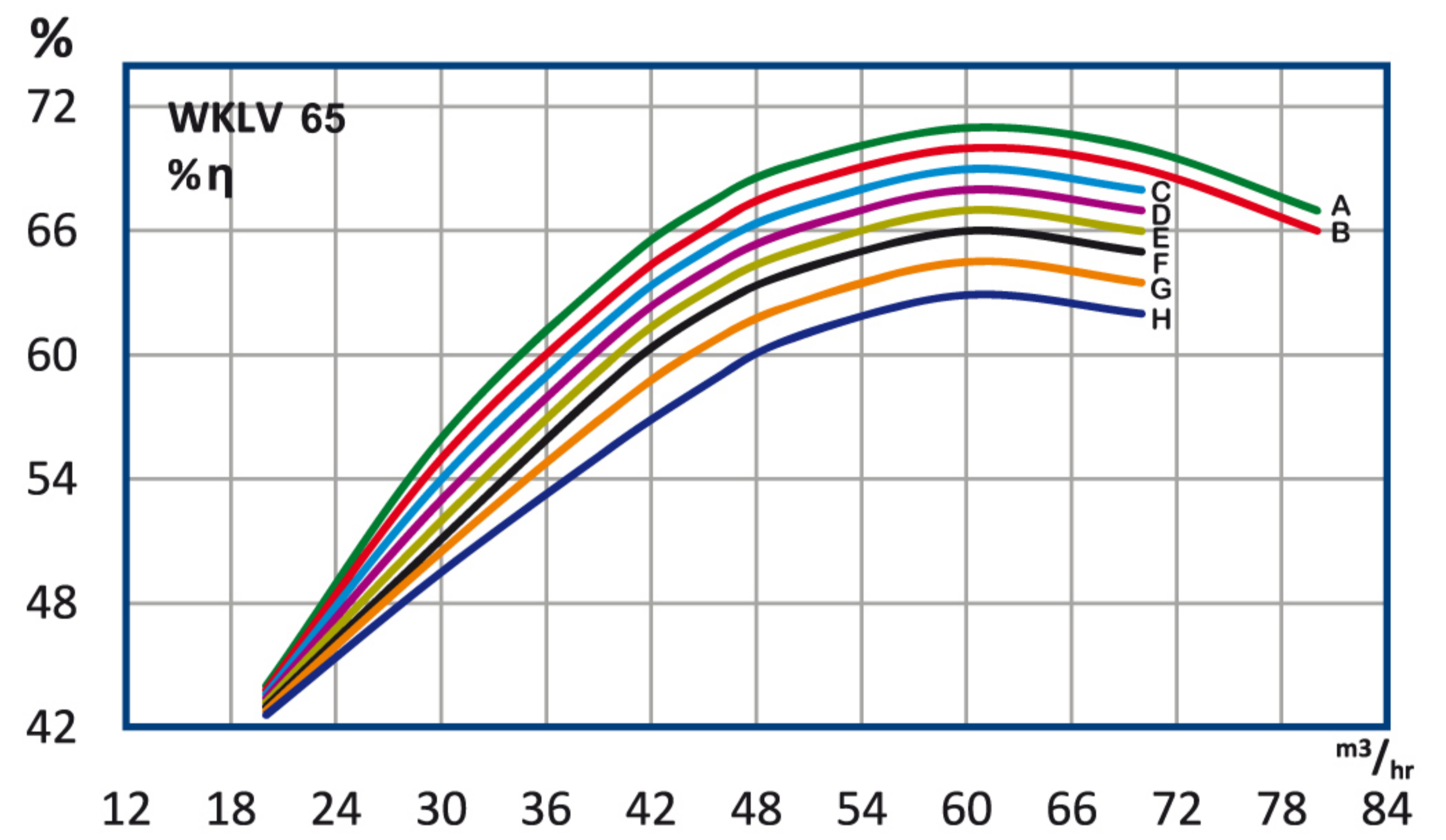
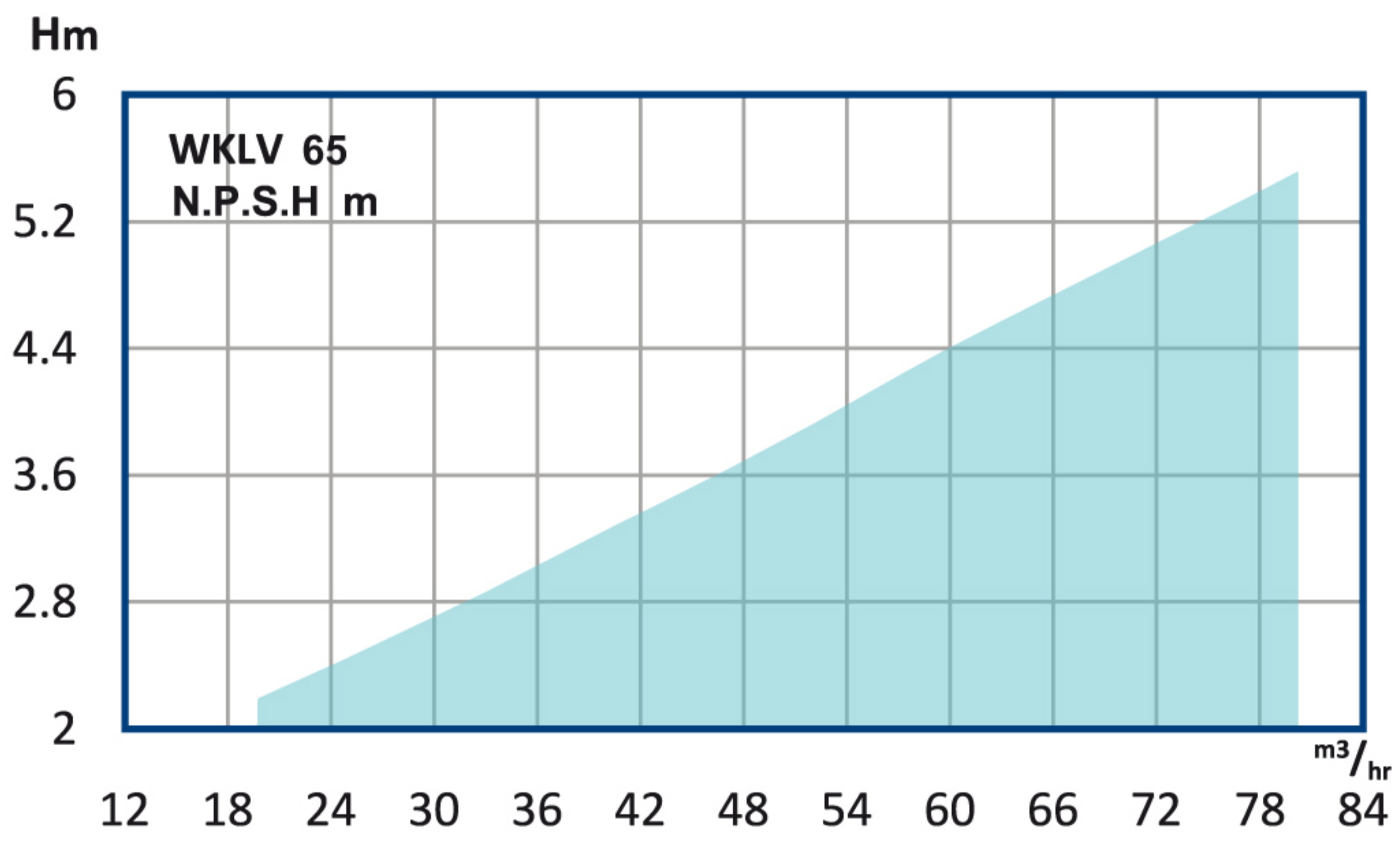
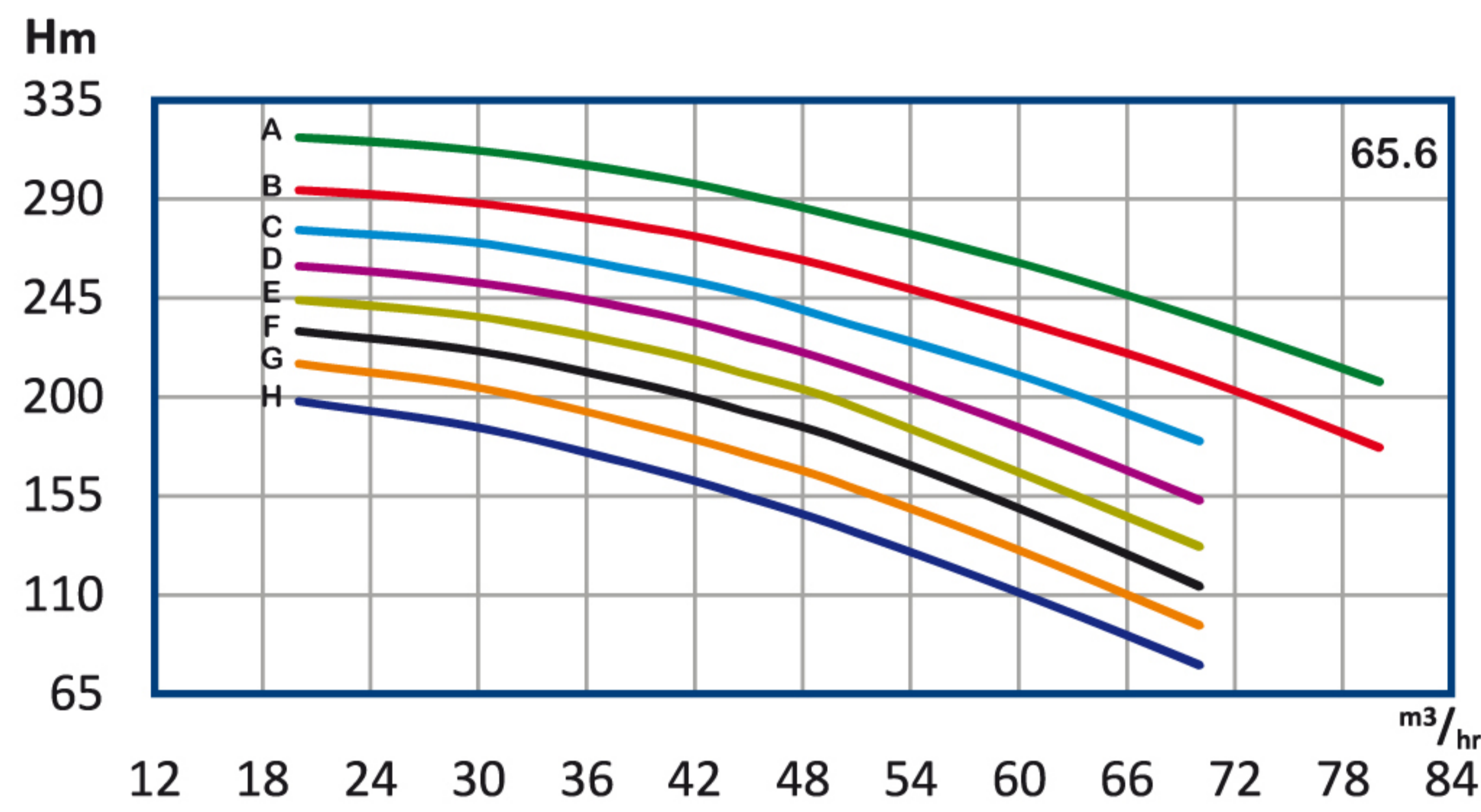
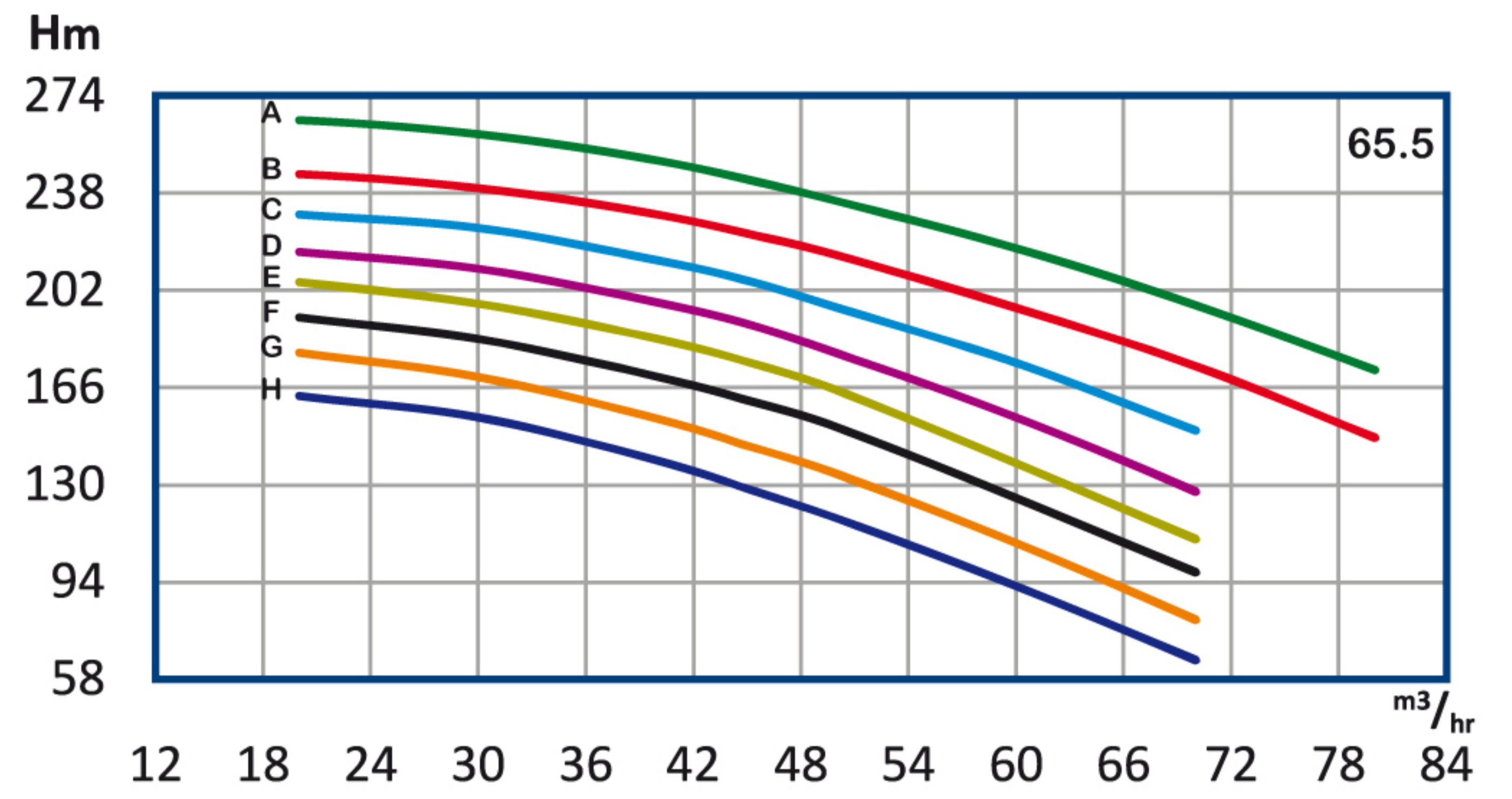
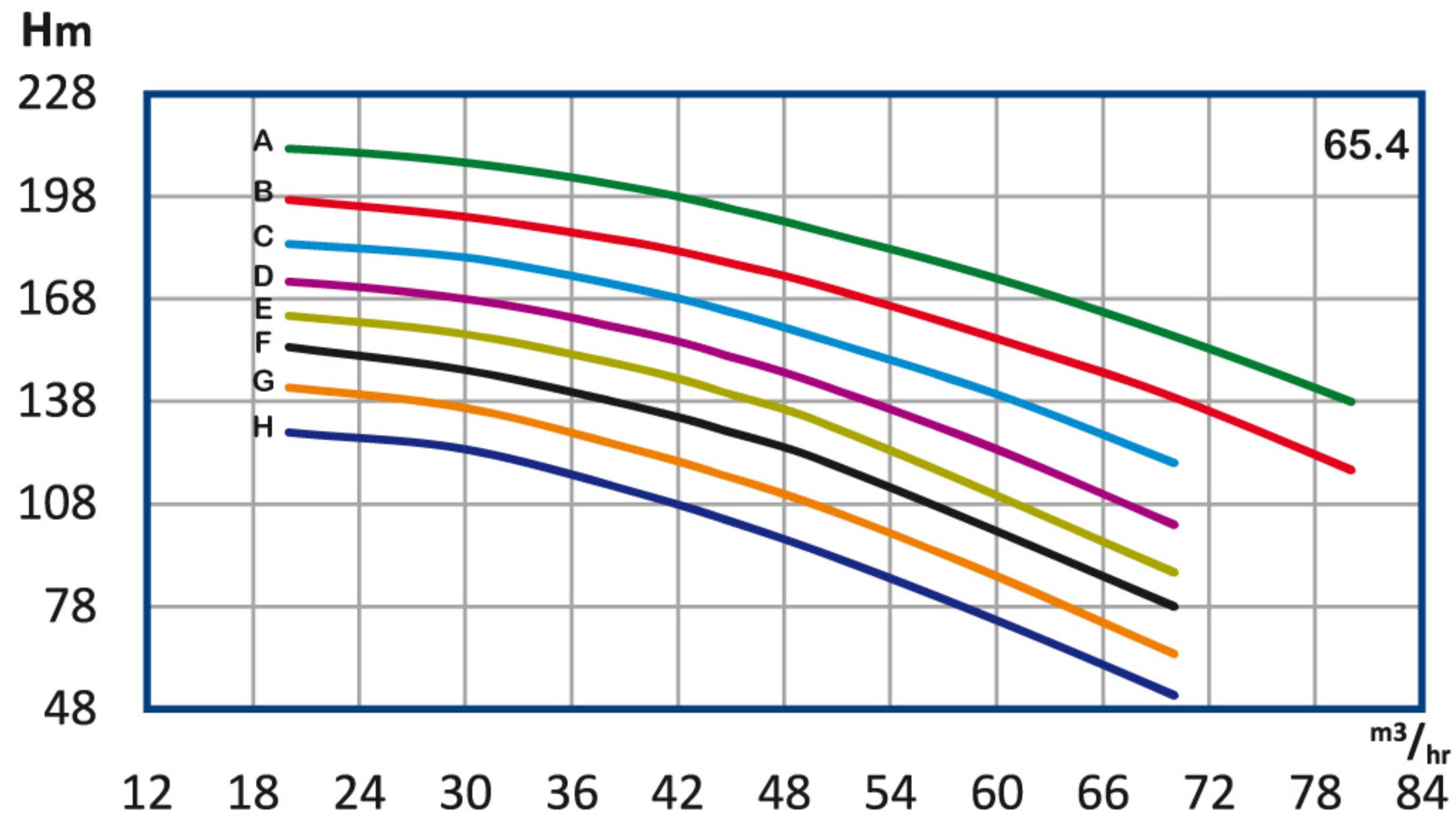

n≈ 2900 rpm

پمپ WKL 65 , WKL V

تیپ پمپ	توان P		آمپر A	قطر پروانه D (mm)	قطر فلنج mm		Q آبدھی								
	KW	HP			مکش	رانس	m <sup>3</sup> /h	20	30	40	45	50	60	70	80
							l/s	5.56	8.34	11.1	12.5	13.9	16.7	19.5	22.3
WKL V 65.7 H	37	50	69	155	80	65	H ( m )	230	217	194	180	165	130	91	*
WKL V 65.7 G	45	60	83	160				251	238	216	202	188	152	112	*
WKL V 65.7 F	45	60	83	165				270	258	238	226	212	175	137	*
WKL V 65.7 E	55	75	104	170				287	276	258	245	231	193	154	*
WKL V 65.7 D	55	75	104	175				303	294	277	266	250	217	179	*
WKL V 65.7 C	60	80	124	180				322	315	298	288	274	245	210	*
WKL V 65.7 B	75	100	140	185				343	336	322	312	301	274	244	207
WKL V 65.7 A	75	100	140	192				371	364	350	340	329	305	275	242
WKL V 65.8 H	45	60	83	155				264	248	222	206	188	148	104	*
WKL V 65.8 G	45	60	83	160				288	272	246	231	214	174	128	*
WKL V 65.8 F	55	75	104	165				308	294	272	258	242	200	156	*
WKL V 65.8 E	60	80	124	170				328	315	294	280	264	221	176	*
WKL V 65.8 D	60	80	124	175				345	336	316	304	286	248	204	*
WKL V 65.8 C	75	100	140	180				368	360	341	329	313	280	240	*
WKL V 65.8 B	90	125	166	185				392	384	368	357	344	313	278	236
WKL V 65.8 A	90	125	166	192				424	416	400	389	376	348	314	276

H	m	91	122	152	183	213	244	274	305	335	366	396	427
	ft	300	400	500	600	700	800	900	1000	1100	1200	1300	1400

Q	m <sup>3</sup> /h	20	30	40	45	50	60	70	80
	g.p.m	76	114	152	170	190	227	265	303

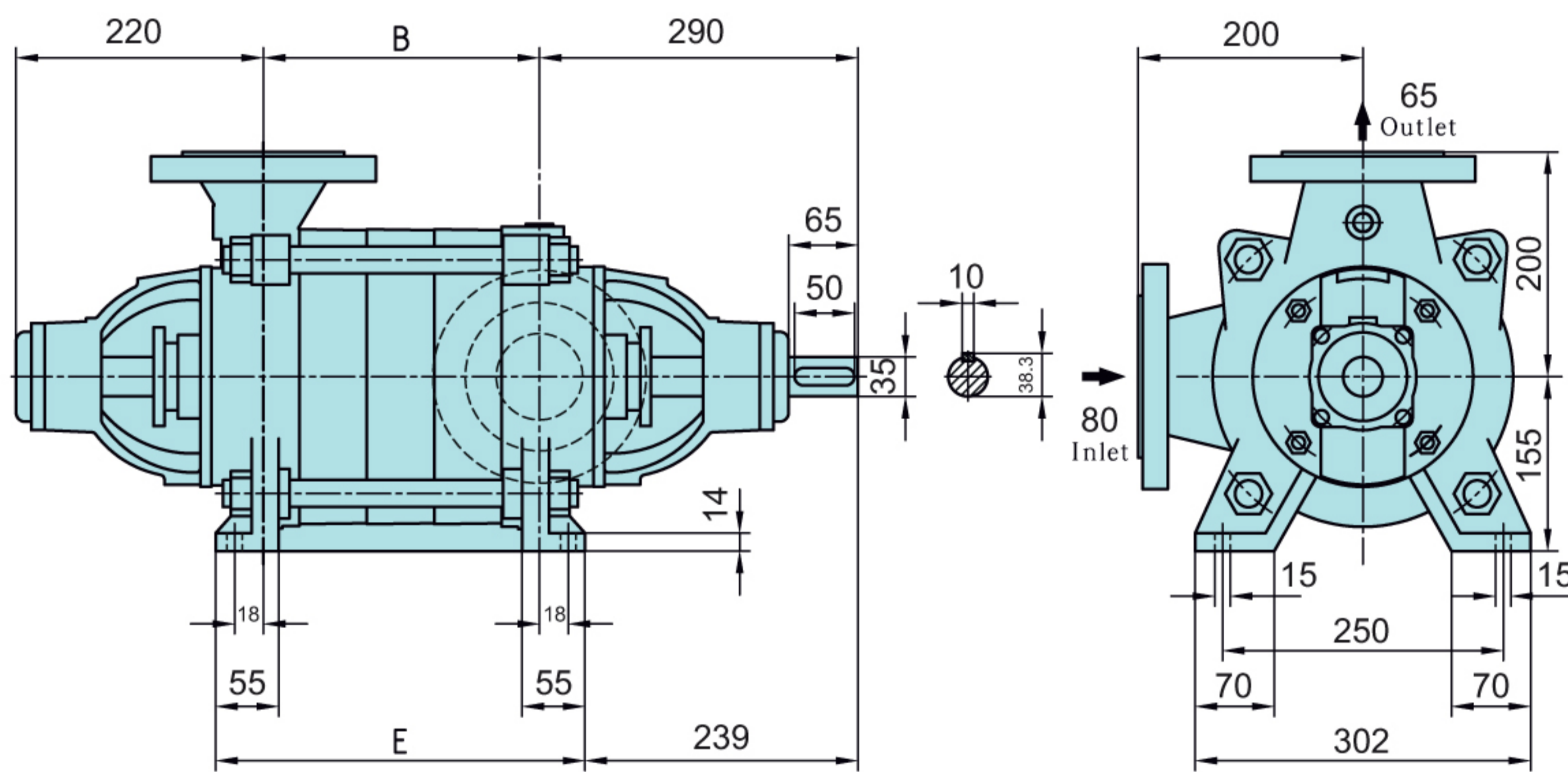
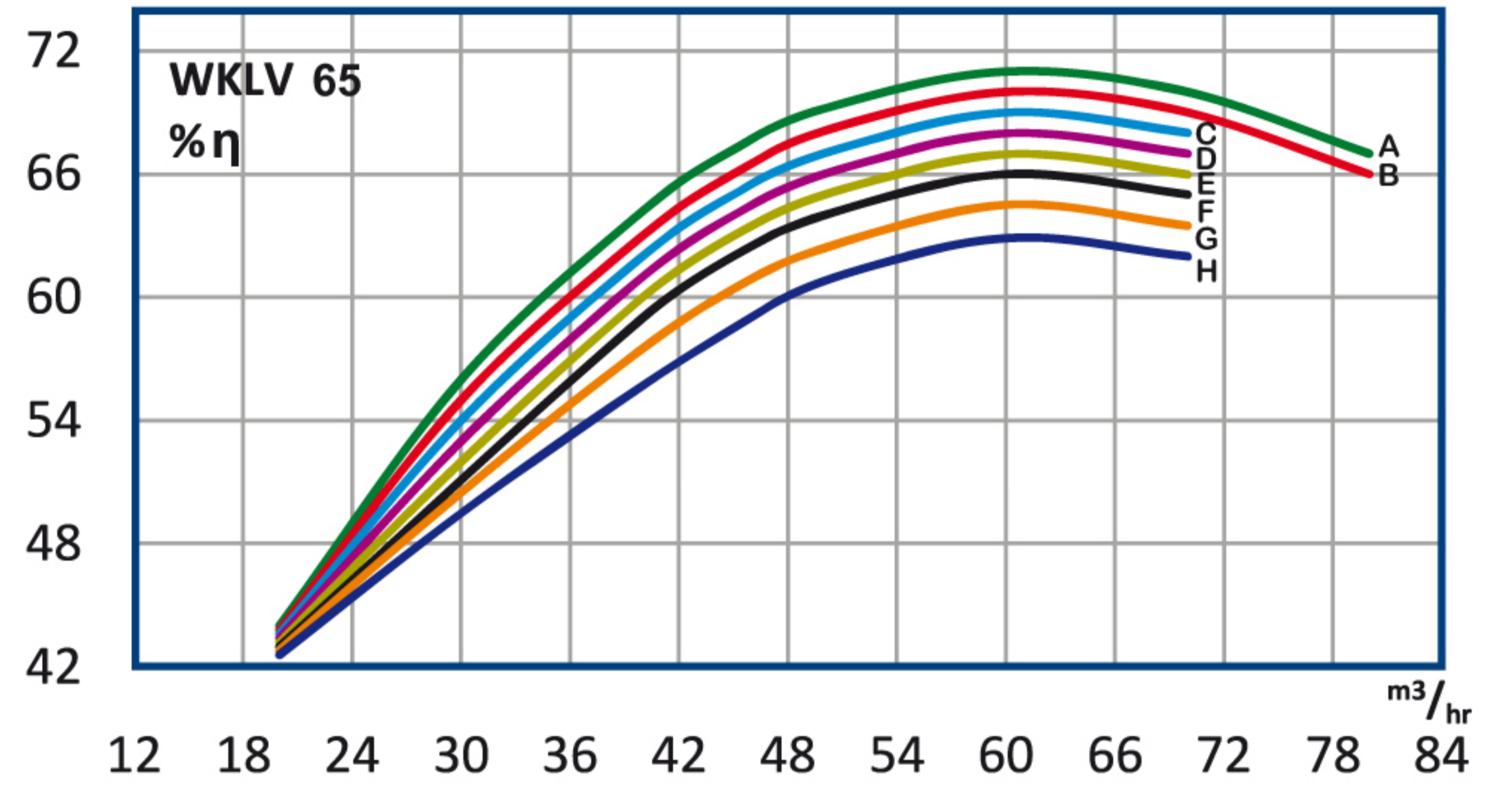
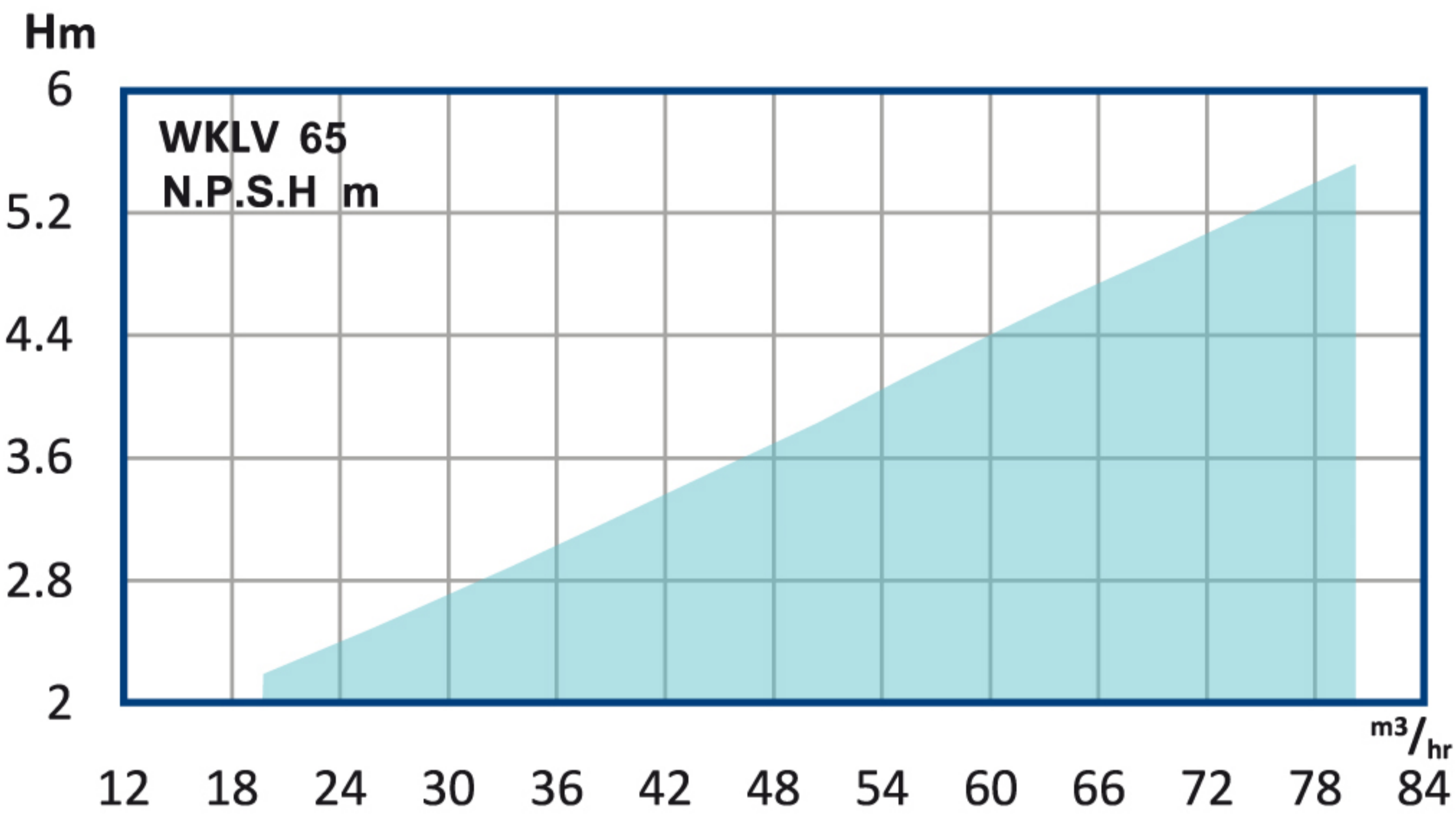
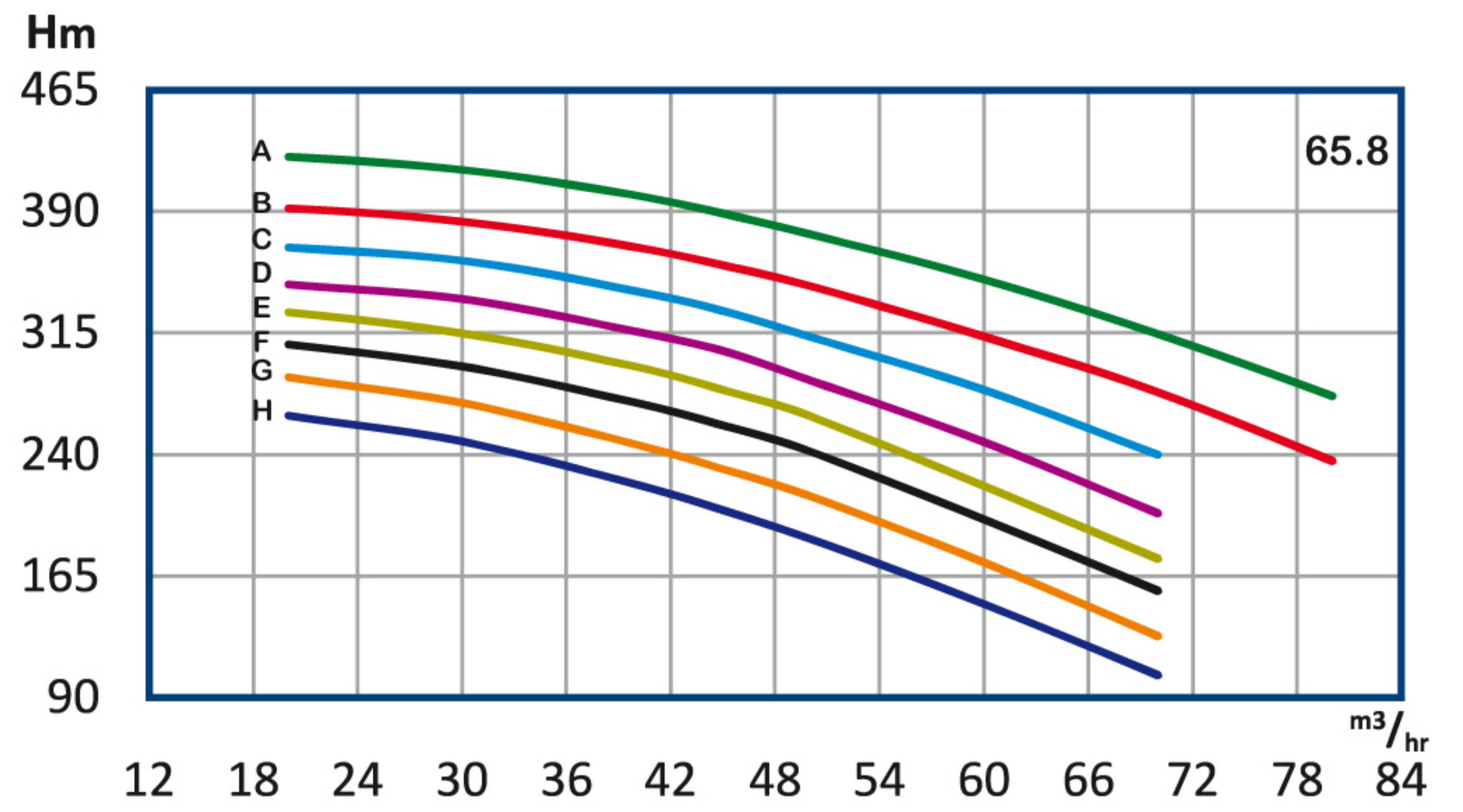
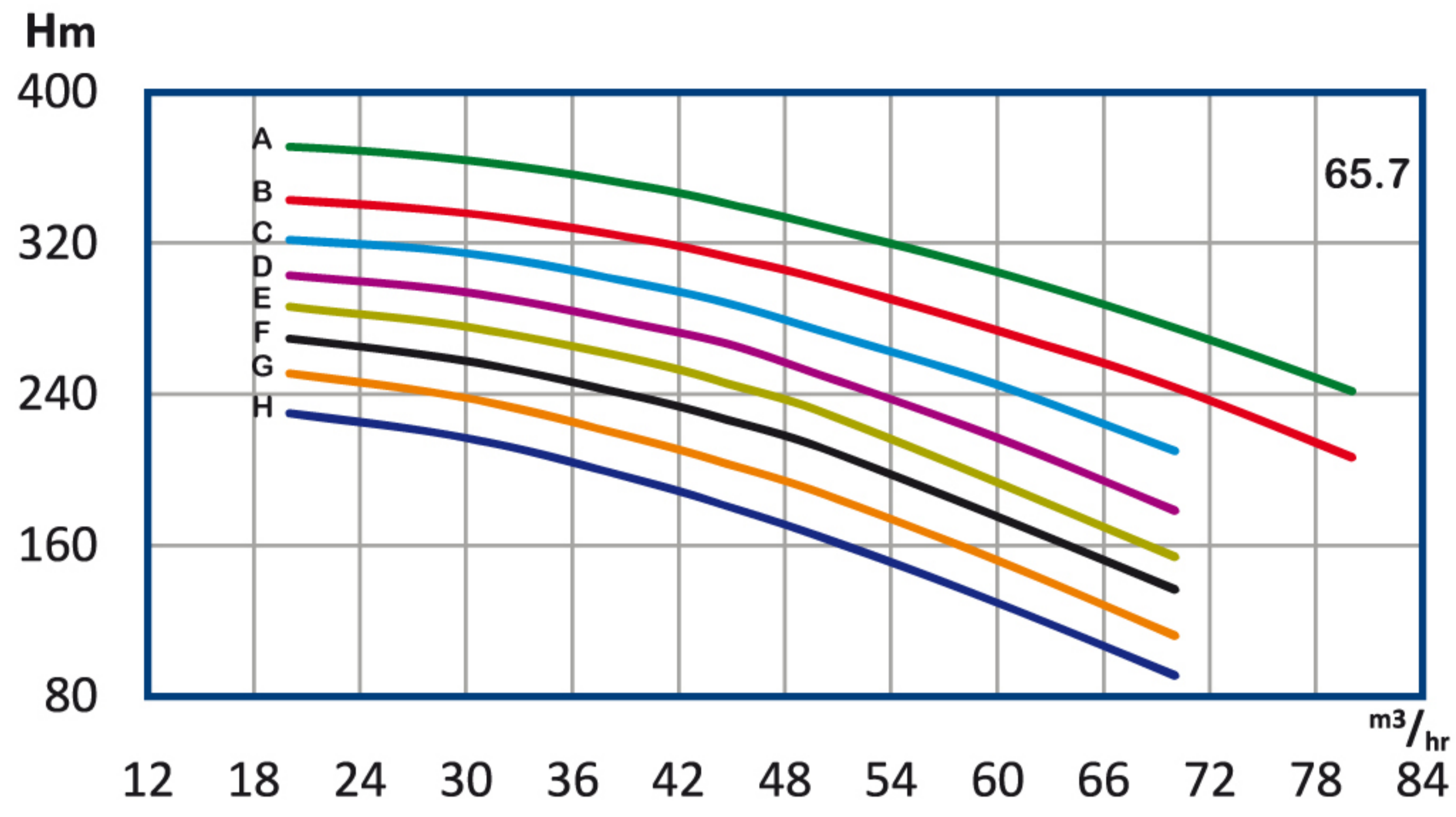

جدول طول پمپ (mm) WKL 65

تعداد طبقه	B	E	تعداد طبقه	B	E
1	87	289	5	327	429
2	147	249	6	387	489
3	207	309	7	447	549
4	267	369	8	507	609

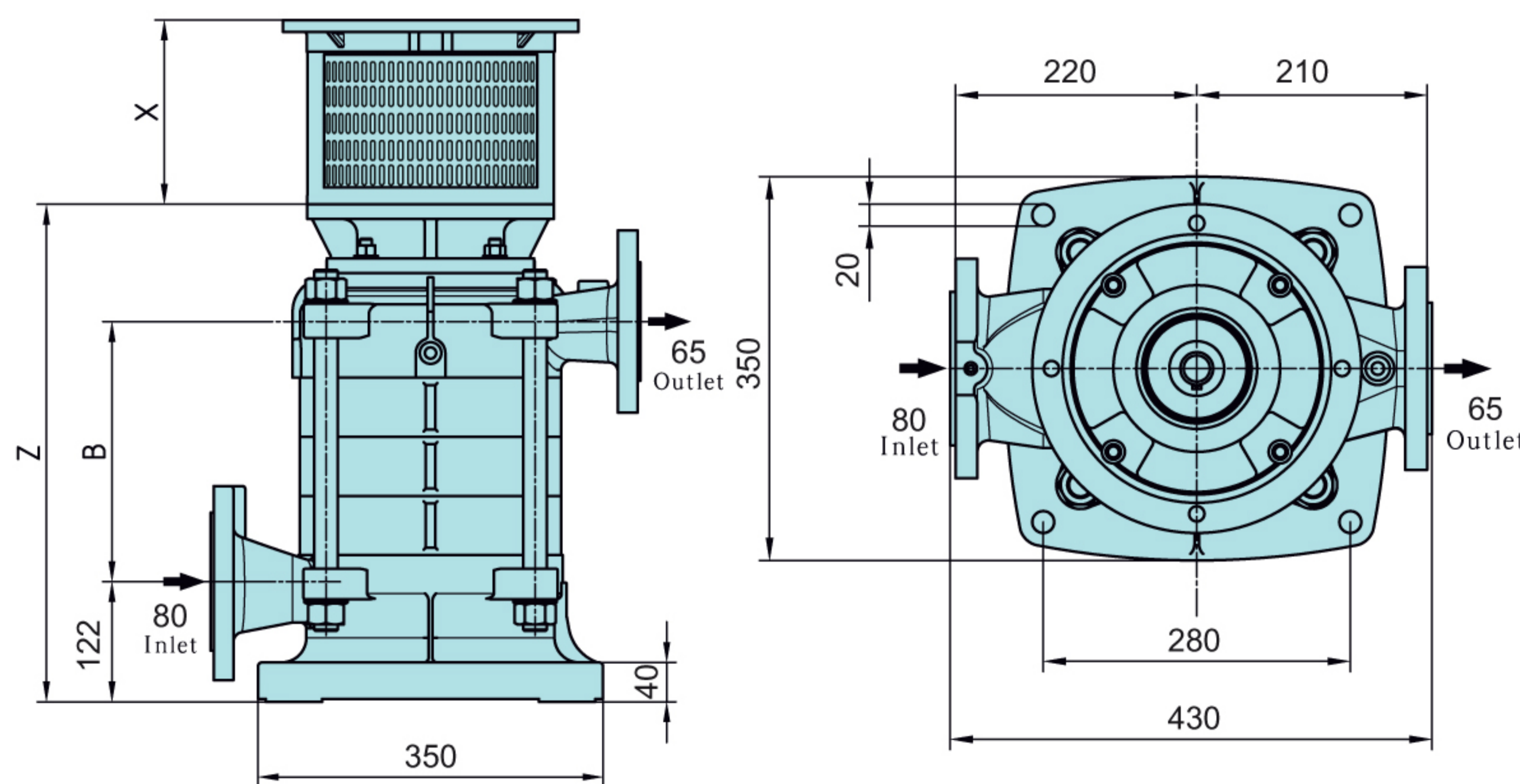

جدول طول پمپ (mm) WKL 65

تعداد طبقه	B	Z	تعداد طبقه	B	Z
1	84	325	5	324	565
2	144	385	6	384	625
3	204	445	7	444	685
4	264	505	8	504	745

X: متناسب با قدرت الکترو موتور تغییر می یابد.

جدول ابعاد پمپ های WKL4 , WKL4 ( 32-65 )

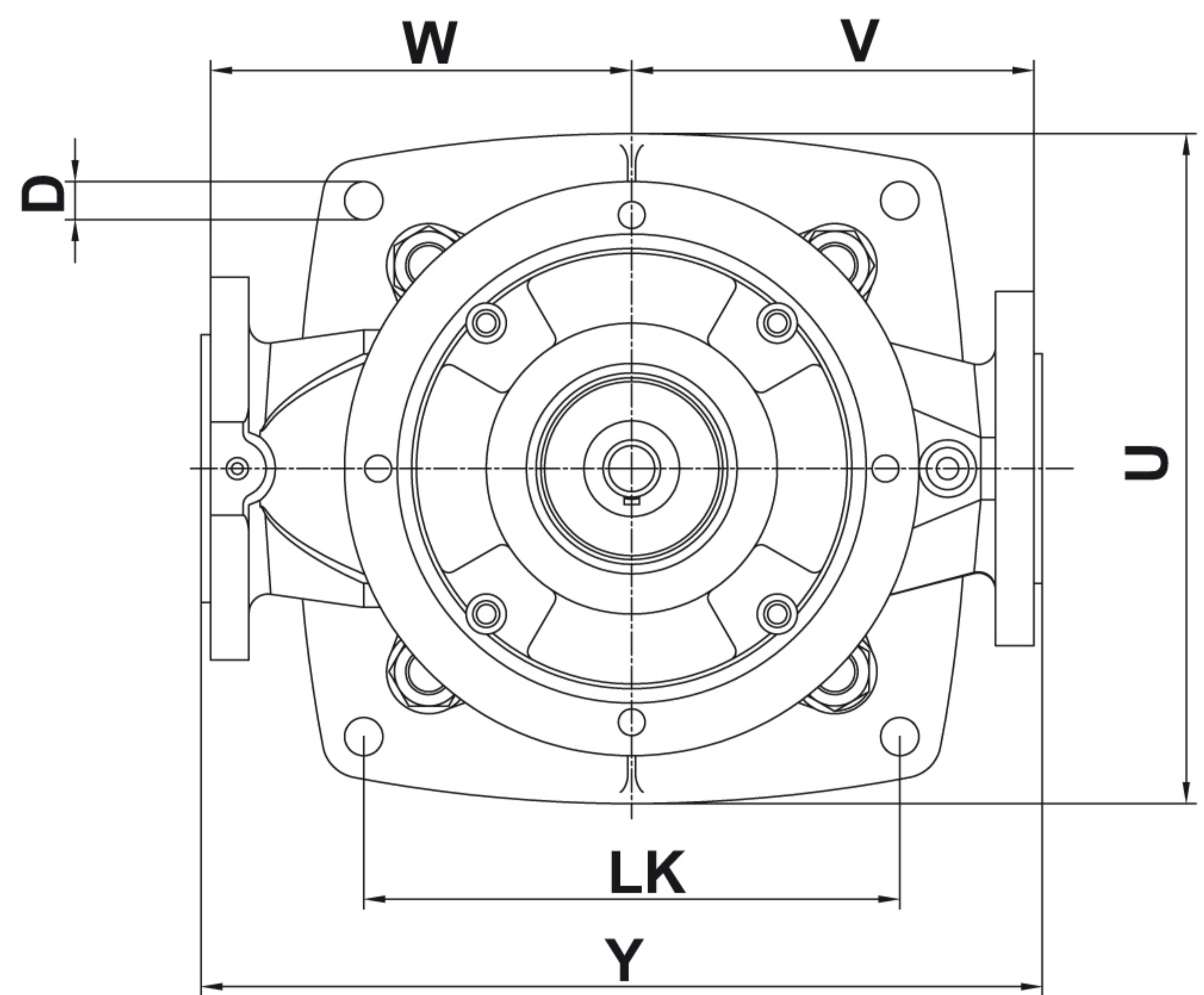
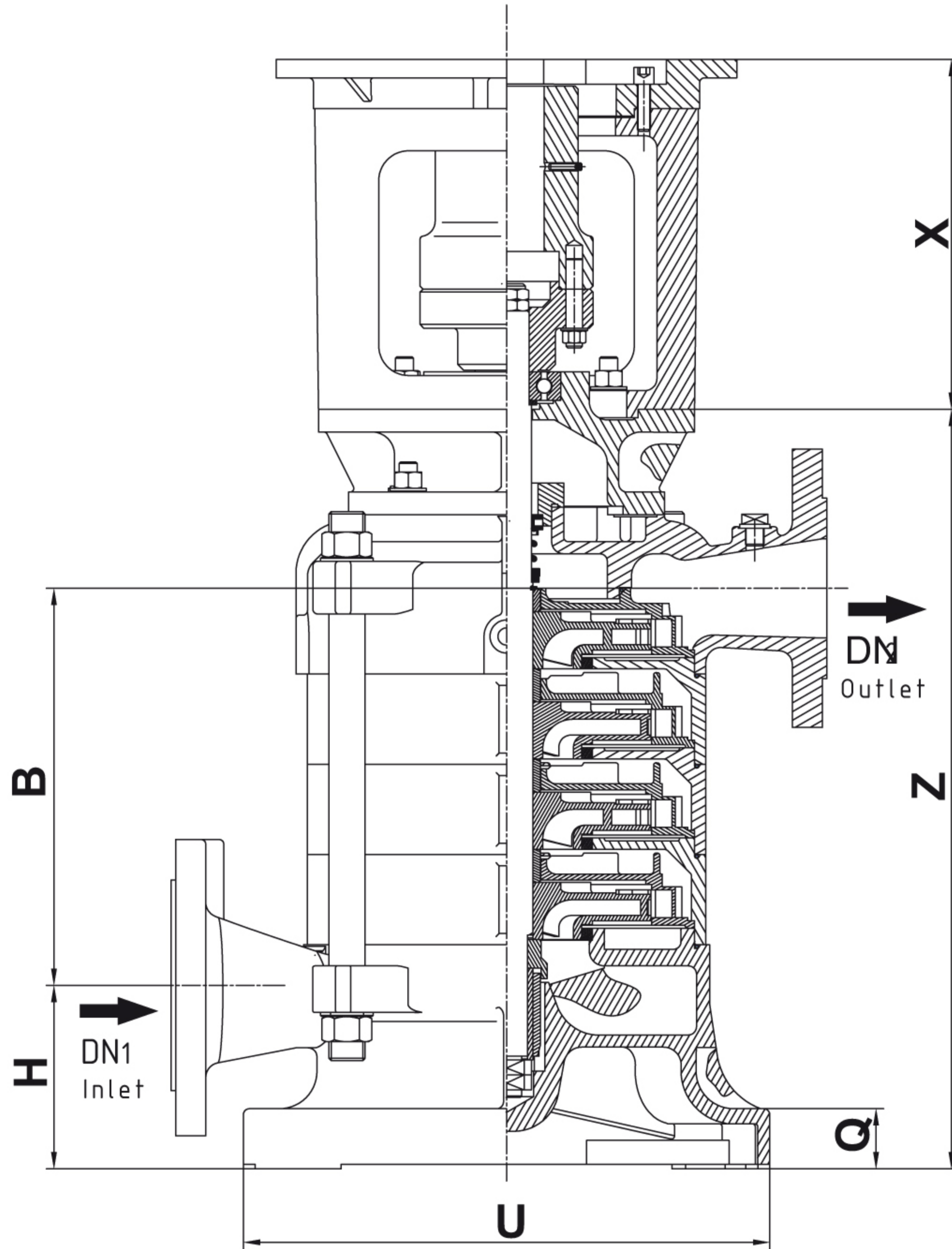

Type	(mm)									
	DN1	DN2	LK	Y	U	D	W	V	Q	H
WKL4 / WKL4 32	40	32	216	349	280	20	180	163	40	92
WKL4 / WKL4 40	50	40	238	370	300	20	192	178	46	94
WKL4 / WKL4 50	65	50	250	392	330	20	206	180	38	103
WKL4 / WKL4 65	80	65	280	430	350	20	220	210	40	122

Type	طول پمپ	(mm)																
		1	2	3	4	5	6	7	8	9	10	11	12	13	14	15	16	17
WKL4 / WKL4 32	B	76	124	172	220	268	316	364	412	460	508	556	604	652	700	748	796	844
	Z	279	327	375	423	471	519	567	615	663	711	759	807	855	903	951	999	1047
WKL4 / WKL4 40	B	89	137	185	233	281	329	377	425	473	521	569	617	665	713	761	809	*
	Z	294	342	390	438	486	534	582	630	678	726	774	822	870	918	966	1014	*
WKL4 / WKL4 50	B	82	137	192	247	302	357	412	467	522	577	632	687	742	797	*	*	*
	Z	310	365	420	475	530	585	640	695	750	805	860	915	970	1025	*	*	*
WKL4 / WKL4 65	B	84	144	204	264	324	384	444	504	564	624	684	747	*	*	*	*	*
	Z	325	385	445	505	565	625	685	745	805	865	925	985	*	*	*	*	*