



GAMAK



TECHNICAL CATALOG



Gamak	4
About Us	6
Factory	7
Export	8
Product Range	10
Technical Information	15
Standards and Recommendations	16
Mechanical Construction	17
Degree of Protection for Frame	17
Bearing Carrier Covers and Flange Enclosures	17
Recommended Heater Powers	18
Cooling (TS 3210 EN 60 034-6)	19
Terminal Box	19
Cable Entry	19
Plastic Terminal Box	19
Aluminum Terminal Box	19
Bearings	19
Standard Design with Fixed Ball Bearing	20
Reinforced Design with Cylindrical Roller Bearing	22
Shaft End	27
Vibration	27
Noise Level	27
Surface Noise - Pressure Level (LpFA)	27
Painting	27
Storage	27
Electrical Construction	28
Frame Forms and Installation Arrangements (TS 3211 EN 60 034-7)	28
Voltage and Frequency	29
Nominal Power	30
Overloadability	30
Nominal Torque	30
Insulation Class	30
Types of Operation	30
Start-up Frequency	34
Allowable Start-up Frequency per Hour at Idle (Zo)	34
Start-up Time	35
Allowable Start-up Time at Direct Start-up (s)	35
Indirect Start	36
Soft Start	36
Electrical Protection of Motors	36
Tolerances (IEC 60 034-1)	36
Standard Series Three Phase Motors	38
High Efficiency Motors with 2 poles- 3000 RPM	40
Aluminum Frame	40
Cast Iron Frame	41
High Efficiency Motors, 4 poles- 1500 RPM	42
Aluminum Frame Cast	42
Iron Frame	43
High Efficiency Motors, 6 poles- 1000 RPM	44
Aluminum and Cast-Iron Frame	44
Standard Series Motors, 2 poles- 3000 RPM	45
Aluminum and Cast Iron Frame	45
Standard Series Motors, 4 poles- 1500 RPM	46
Aluminum and Cast Iron Frame	46
Standard Series Motors, 6 poles- 1000 RPM	47
Aluminum and Cast Iron Frame	47
Standard Series Motors, 8 poles- 750 RPM	48
Aluminum and Cast Iron Frame	48
Premium Efficiency Motors	50
Cast iron frame, 2 poles- 3000 RPM	50
Cast iron frame, 4 poles- 1500 RPM	51
Premium Efficiency Motors	52
Cast iron frame, 6 poles- 1000 RPM	52
Dual Speed Motors, 4/2 poles, 1500/3000 RPM	53
Motors with Dahlander Connections	53
Motors with Two Different Windings	53

Dual Speed Motors, 4/2 poles, 1500/3000 RPM	54
(Constant Load Torque)	
Dual Speed Motors with 8/4 poles, 750/1500 RPM	55
(Constant Load Torque)	
Dual Speed Motors, 6/4 poles, 1000/1500 RPM	56
(Constant Load Torque)	
Dual Speed Motors, 4/2 poles, 1500/3000 RPM	57
Proportional to the Square of the Load Torque)	
Dual Speed Motors, 8/4 poles, 1500/3000 RPM	58
Proportional to the Square of the Load Torque)	
Dual Speed Motors, 6/4 poles, 1500/3000 RPM	59
Proportional to the Square of the Load Torque)	
Options	60
Three Phase Squirrel Cage Induction Motors	60
Foot-Mounted (B3) - Aluminum Frame	61
Foot-Mounted (B3) - Cast Iron Frame	62
(Form A-B5) - Aluminum Frame with Flange	63
(Form A-B5) - Cast Iron Frame with Flange	64
(Form A-B35) - Foot-Mounted Aluminum Frame and Flange	65
(Form A-B35) - Foot-Mounted Cast Iron Frame and Flange	66
(Form C-B14) - Aluminum Frame with Flange	67
(Form C-B14) - Cast Iron Frame with Flange	68
Foot Mounted and Flanged (Form C-B34) - Aluminum Frame	69
(Form C-B34) - Foot-Mounted Cast Iron Frame and Flange	70
Spare Parts	71
Standard Series Single Phase Motors	72
Single Phase Fully Enclosed (IP 55) Standard Asynchronous Motors	74
Design with Permanent Circuit Capacitor	74
Start-up + Design with Permanent Circuit Capacitor	74
Electronic Relay	74
Centrifugal Switch	74
Frame, Bearing Carrier Covers and Flanges	75
Enclosure Degree of Protections	75
Terminal Box	75
Cable Entry	75
Shaft End	75
Vibration	75
Painting	75
Storage	75
Bearings	75
Allowable Mechanical Forces	76
Allowable External Axial Forces	76
Voltage and Frequency	77
Nominal Power	77
Nominal Torque	77
Changing the Direction of Rotation	77
Idling	77
Operational Characteristics	78
Motors with Permanent Circuit Capacitor (M21D)	78
Start-up + Motors with Permanent Circuit Capacitor (MS21D)	79
Start-up + Motors with Permanent Circuit Capacitor (MK21D)	80
Single Phase Motors (Motor Dimensions)	81
Foot Mounted Motor - B3, B6, B7, B8, B15, V5, V6	81
Motor with Flange (Form "A" - DIN EN 50 347) - B5, V1, V3	81
Foot-Mounted Motor and Flange (Form "A" - DIN EN 50 347) - B35	82
Motor with Flange (Form "C" - DIN EN 50 347) - B14, V18, V19	82
Foot-Mounted Motor and Flange (Form "C" - DIN EN 50 347) - B34	83
Spare Parts	84
New Series Motors	85
Attachable Feet Housings	86
Fixed Feet Housing	86
Frame, Bearing Carrier Covers and Flanges	86
High Efficiency Motors	87
Aluminum Frame, 2 poles (3000 RPM)	87
High Efficiency Motors	88
Aluminum Frame, 4 poles (1500 RPM)	88
Aluminum Frame, 6 poles (1000 RPM)	88
Cast Iron Frame, 2 poles (3000 RPM)	89

Cast Iron Frame, 4 poles (1500 RPM)	89
Cast Iron Frame, 6 poles (1000 RPM)	89
New Series Premium Efficiency Motors	90
Aluminum Frame, 2 poles (3000 RPM)	90
Aluminum Frame, 4 poles (1500 RPM)	90
Aluminum Frame, 6 poles (1000 RPM)	90
Cast Iron Frame, 2 poles (3000 RPM)	91
Cast Iron Frame, 4 poles (1500 RPM)	91
Cast Iron Frame, 6 poles (1000 RPM)	91
New Series Motors	92
Aluminum Frame, 2 poles (3000 RPM)	92
Spare Parts	94
(B3) Foot-Mounted Motors	95
Aluminum and Cast Iron Frame	95
(Form A - B5) Motors with Flange	96
Aluminum and Cast Iron Frame	96
(Form C - B35) Motors Foot-Mounted and Flange	97
Aluminum and Cast Iron Frame	97
(Form C - B14) Motors with Flange	98
Aluminum and Cast Iron Frame	98
(Form C - B34) Motors with Flange	99
Aluminum and Cast Iron Frame	99
Special Series Smoke Extraction Motors	100
Mechanical Properties	102
Operational Characteristics	103
2 poles (3000 RPM)	104
4 poles (1500 RPM)	105
Dual Speed Smoke Extraction Motors	105
Dahlander Link Proportional to the Square of the Speed Load Torque	
4/2 poles (1500/3000) RPM	105
8/4 poles (750/1500) RPM	105
Dual Speed Smoke Extraction Motors	106
(Proportional to the Square of the Speed Load Torque -	
Two Different Windings)	
6/4 poles (1000/1500) RPM	106
Dimensions Fully Closed Cooled with Air Passing Over (TEAO) Motors	107
Foot-Mounted (B3) - Cast Iron Frame	107
Spare Parts	108
Pad Mounted Smoke Extraction Motors	109
2 poles (3000 RPM)	109
4 poles (1500 RPM)	109
4/2 poles 1500/3000 RPM	110
8/4 poles , 750/1500 RPM	110
6/4 poles , 1000/1500 RPM	110
Pad Mounted Smoke Extraction Motors	110
Dimensions - Pad Mounted Smoke Extraction Motors	111
Spare Parts	112
Special Series Ex-Proof Motors	114
Gamak Flame Proof Ex-Proof Motors	116
Ex-Proof Series - Operational Characteristics Standard Efficiency Motors (IE1)	117
2 poles (3000 RPM)	117
4 poles (1500 RPM)	117
6 poles (1000 RPM)	118
8 poles (750 RPM)	118
Ex-Proof Series - Operational Characteristics Standard Efficiency Motors (IE2)	119
2 poles (3000 RPM)	119
4 poles (1500 RPM)	120
6 poles (1000 RPM)	121
Spare Parts	122
Foot Mounted (B3) Cast Iron Ex-Proof Motors	123
Foot Mounted (B35) Cast Iron Ex-Proof Motors	124
Special Series Crusher Motors	126
Crusher Motors	128
Crushing - Technical Characteristics Standard Efficiency Motors	129
Fixed Feet Hosing, 4 poles (1500 RPM)	129

Attachable Feet Housings, 4 poles (1500 RPM)	129
Fixed Feet Housing, 4 poles (1500 RPM)	130
Attachable Feet Housings, 4 poles (1500 RPM)	130
Spare Parts	132
Special Series Milking Machine Motors	134
Milking Machine Motors	136
Milking - Technical Characteristics	137
Special Milking Machine Motors With Permanent Circuit Capacitors	137
4 poles (1500 RPM), with Fixed Feet Housing	137
4 poles (1500 RPM), with Fixed Feet Housing	137
General Information	138
Speed Control Applications	140
Speed Adjustment for Caged Asynchronous Motors	140
Operating below and above the Nominal Value in Speed Control	141
Applications	
Operating Below Nominal Speed	141
Encoder Usage	141
Major Issues to Consider in Encoder Selection	141
As follows	
Forced Cooling Kit	142
Operating Above Nominal Speed	142
Shaft Voltages	143
Important Note	143
Pulleys for Belts	144
Efficiency and Power Coefficient at Different Loads	145
Operations and Maintenance Data	146
Transport	146
Ventilation and Cooling	146
Water Drain Holes	146
Elimination of Parasites	146
Installation	146
Alignment	146
Transmission Concepts and	147
Balancing Pulleys	147
Insulation Resistance	147
Putting into Operation	148
Maintenance of Bearings	148
Changing Bearings	149
Bearings Seals	149
Possible Motor Malfunctions and Remedies	150
Index	152

* GAMA reserves the right to partially or completely change the technical specifications given in this catalog without prior notice.



ABOUT US

GAMAK was founded in 1961 to overcome the shortage of domestic products in the field of “Electric Motor”, which is one of the most important products needed by the Turkish industry for manufacturing. In a short time, we started to produce the first electric motors of Turkish origin. We created an alternative that eliminated the problems associated with the cost, spare parts supply and price by the use of imported motors. We have been appreciated for our quality. We have continued to grow and develop day by day.

In half a century, we have become one of the leading electric motor manufacturers not only in Turkey, but also in the world. With our electric motors that we produce in the power range of 0.06 kW - 3.000 kW, we have succeeded in meeting almost all needs in the motor industry. We have produced almost each part required for the electric motor in our own plant; we have gathered the entire production under one roof. We have become one of the two producers in the world that can produce their own wire. We have established one of Europe’s leading laboratories; we opened a new era in efficiency.

Today, we continue to strengthen the production power of the Turkish industry with our 50,000 m² production plant on 330,000 m² land and a team of approximately 1,000 employees.

FACTORY

In our production plant built on a 38.000 m² land in Topkapı in the early 60’s, we had produced the first electric motor of Turkey with type 90 body and 1,5 kW power. When we started mass production in 1965, our production capacity was limited to only 1,000 units per year. We started to manufacture every part used in the production of the electric motors by ourselves in our 50,000 m² facility on 330,000 m² land in Dudullu built by the mid-70s. The manual processes in the production of the electric motors were automated in the course of time. Although there are still departments where competent manpower is used, the production is largely made by the machines of modern technology. Today, our factory includes units such as pressing, mechanical processing, wire winding, assembly, molding, repair and maintenance, aluminum injection, where the production of lighter bodies is made, special production units according to demand and needs, a laboratory which is one of the few test stations in Europe and the unit of wire enamel where we produce copper wire. Indeed, we are one of the two companies in the world producing copper wire.

Our production plant is one of the few electric motor factories in the world, and all production is gathered under a single roof. There we have the capacity to produce 1,000,000 units of product per year with aluminum and cast iron bodies, 0.06 - 3,000 kW power and 56 - 630 types. Every single day, we take our production and quality to the next level, with both our competent workforce and our state-of-the-art machinery.



As one of the few companies in the world that can produce its own wire, we use wires that we thin between 2 mm - 0.2 mm for our products. In our facility where we have one of the few laboratories in Europe, we produce the highest standard products with maximum efficiency. On one hand, we produce motors with high efficiency (IE2 - IE3), on the other hand, we create the infrastructure required for the production of new generation, efficient motors (IE4) with our R&D investments. Thanks to this potential, we manage the production in a fast, dynamic and flexible fashion. With our ability to produce special motors for special demands and needs, which cannot be fulfilled by other companies in the world, we participate in important projects in our country and in the world (especially in public space projects). In production, we compete with our only true competitor in the world, ourselves, every day.

EXPORT

At GAMAK, we do not stop seeing our superiority in the domestic market; we also give great importance to increasing our global market share. We export our motors (IE3) produced in accordance with the European Standards to more than 40 countries in almost every region of the world, especially in the EMEA region. Particularly, we are among the top 10 companies that export electric motors to the EMEA region. In addition to our new technology motors with high efficiency standards, we continue to manufacture and export (IE1 - IE2) motors preferred especially in the Middle Eastern and African regions. Thanks to the mobility provided by the production of all parts in our own plant, we can build our machine park to produce according to the standards required by the regions. This operation gives great advantage to us in meeting all needs in the field of export and enables us to differentiate from our competitors.



”

PRODUCT RANGE

“

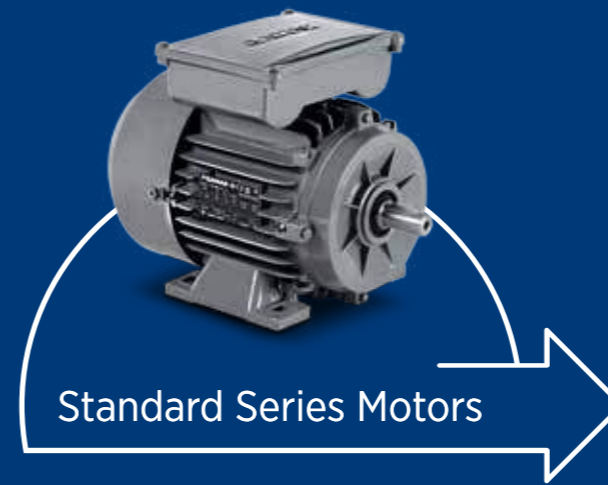

- **Single Phase**
 - Permanent Circuit Capacitor
 - Start-up + Permanent Circuit Capacitor
- **3 Phase**
 - **Single Speed**
 - IE
 - IE2
 - IE3
 - **Dual Speed**
 - Constant Load Torque
 - Load Torque Proportional to the Square of the Speed



- **3 Phase Motors**
 - IE2 (2, 4, 6 Poles)
 - IE3 (2, 4, 6 Poles)



- **Smoke Extraction Motors**
 - Smoke Extraction Foot Mounted Motors
 - Dual Speed Single Speed Ventilation
 - Pad Mounted Smoke Extraction Motors
 - Single Speed
 - Dual Speed
- **Ex-Proof Motors**
 - d Class
 - Flame Proof
 - IE1 2, 4, 6, 8 poles
 - IE2 2, 4, 6 poles
- **Crusher Motors**
 - IE2
 - IE3
- **Milking Machine Motors**
 - Permanent Circuit Capacitor

G2TA		A	O80	M	2	A	B142	1A	O1	AAB					
G1TA	General Purpose Attachable Feet Housings IE1	A AL	063	Motor Types S	Frame Length 2	No of Poles A	Package Length B3	Order of Installation —	Voltage Motor Characteristic —	Special Version Motor Types					
G2TA	General Purpose Attachable Feet Housings IE2	P Pk	071							M	4	B	B6	Special Shaft Motors	European Motors
G3TA	General Purpose Attachable Feet Housings	—	080							L	6	C	B7	Milking Machine Motors	UL Motors
G4TA	General Purpose Attachable Feet Housings IE4	—	090							H	8	D	B8	Crusher Motors	Tropic Motors
G1SA	General Purpose Fixed Feet Housing IE1	—	100							—	10	E	V5	—	Marine Motors
G2SA	General Purpose Fixed Feet Housing IE2	—	112							—	12	—	V6	—	Cooling Tower Motors
G3SA	General Purpose Fixed Feet Housing IE3	—	132							—	4/2	—	B5	—	Stator with Windings
G4SA	General Purpose Fixed Feet Housing IE4	—	160							—	8/4	—	V1	—	Raw Rotor
M1SD	Single Phase Permanent Circuit	—	180							—	6/4	—	V3	—	Stator without Windings
M1SM	Single Phase Start-up + Permanent Circuit	—	200							—	12/4	—	B14	—	—
M1SR	Single Phase Start-up + Permanent Circuit with Relay	—	225	—	—	—	B18	—	—						
D2F3	Smoke Fixed Feet Housing IE2 f300	—	250	—	—	—	V19	—	—						
D2F4	Smoke Foot Mounted IE2 f400	—	280	—	—	—	B35	—	—						
D2P3	Smoke Pad Mounted IE2 f300	—	315	—	—	—	V15	—	—						
D2P4	Smoke Pad Mounted IE2 f400	—	355	—	—	—	V36	—	—						
V1CD	Ventilation - Multi Speed	—	400	—	—	—	B34	—	—						
T1CD	Machine Tool - Multi Speed	—	450	—	—	—	V15	—	—						
E1SA	Exproof IE1	—	—	—	—	—	V36	—	—						
E2SA	Exproof IE2	—	—	—	—	—	V34	—	—						
—	—	—	—	—	—	—	V58	—	—						
—	—	—	—	—	—	—	V69	—	—						
—	—	—	—	—	—	—	B9	—	—						
—	—	—	—	—	—	—	V8	—	—						
—	—	—	—	—	—	—	V9	—	—						
—	—	—	—	—	—	—	B15	—	—						
—	—	—	—	—	—	—	B30	—	—						
—	—	—	—	—	—	—	B342	—	—						
—	—	—	—	—	—	—	—	—	Special Flange-BS						

Level1 Product Type	Level2 Motor Type	Level3 No of Phases	Level4 Purpose of Usage	Level5 Frame Type	Level6 Feet Housing Selection	Level7 Efficiency				
Asynchronous Squirrel Cage Electric Motors	General Purpose Motors	Three Phase Motors	IEC Standard Motors	Cast Iron Frame	Standard Fixed Feet Housing	IE1 G1SSP IE2 G2SSP IE3 G3SSP IE4 G4SSP				
					Standard Feet Housing	IE1 G1TSP IE2 G2TSP IE3 G3TSP IE4 G4TSP				
					Fixed Feet Housing	IE1 G1SAP IE2 G2SAP IE3 G3SAP IE4 G4SAP				
					Aluminum Frame	Standard Fixed Feet Housing	IE1 G1SSA IE2 G2SSA IE3 G3SSA IE4 G4SSA			
						Fixed Feet Housing	IE1 G1SAA IE2 G2SAA IE3 G3SAA IE4 G4SAA			
						Feet Housing	IE1 G1TAA IE2 G2TAA IE3 G3TAA IE4 G4TAA			
						Fixed Feet Housing	IE1 N1SDA IE2 N1TDA IE3 N1SRA IE4 N1TRA			
						Feet Housing	IE1 N1SMA IE2 N1TMA IE3 N1SDA IE4 N1TDA			
					Single Phase Motors	Permanent Capacitor Motors	Aluminum Frame	Fixed Feet Housing	IE1 N1SDA	
						Motors with Start-up Relay	Aluminum Frame	Fixed Feet Housing	IE1 N1SRA	
				Centrifuge Motors		Aluminum Frame	Feet Housing	IE1 N1TRA		
				New Permanent Capacitor Motors		Aluminum Frame	Fixed Feet Housing	IE1 N1SMA		
				Motors with New Start-up Relay		Aluminum Frame	Feet Housing	IE1 N1TMA		
				Multi Speed Motors		Three Phase Motors	Dahlender D/YY Fixed Torque	Cast Iron Frame	Fixed Feet Housing	IE1 C1SAP
								Aluminum Frame	Standard Fixed Feet Housing	IE1 C1SSP
		Aluminum Frame	Standard Fixed Feet Housing					IE1 C1SSA		
		Dahlender Y/YY Variable Torque	Cast Iron Frame				Fixed Feet Housing	IE1 C1SAA		
			Aluminum Frame				Standard Fixed Feet Housing	IE1 C1TAA		
			Aluminum Frame				Standard Fixed Feet Housing	IE1 C2SAP		
		Single Phase Motors	Double Winding Y/Y Fixed Torque			Cast Iron Frame	Standard Fixed Feet Housing	IE1 C2SSP		
						Aluminum Frame	Standard Fixed Feet Housing	IE1 C2SSA		
						Aluminum Frame	Fixed Feet Housing	IE1 C2SAA		
			Double Winding Y/Y Variable Torque			Cast Iron Frame	Fixed Feet Housing	IE1 C2TAA		
					Aluminum Frame	Fixed Feet Housing	IE1 J1SAP			
					Aluminum Frame	Standard Fixed Feet Housing	IE1 J1SSP			
		Three Speed Y-Δ/YY Fixed Torque	Cast Iron Frame		Standard Fixed Feet Housing	IE1 J1SSA				
			Aluminum Frame		Standard Fixed Feet Housing	IE1 J1SAA				
			Aluminum Frame		Feet Housing	IE1 J1TAA				
		Special Motors	Three Phase Motors	Single Phase Motors	Copper Wire Milking Machine Motors	Aluminum Frame	Fixed Feet Housing	IE1 M1SBA		
					Alm. Wire Milking Machine Motors	Aluminum Frame	Fixed Feet Housing	IE1 M1SSA		
	Oil Pump Motors				Without Body	Without Feet	IE1 Y1P1A			
	Crusher Motors			Cast Iron Frame	Standard Fixed Feet Housing	IE2 K2SSP				
					Standard Fixed Feet Housing	IE3 K3SSP				
					Feet Housing	IE4 R4TAA				
				RAM Motors	Aluminum Frame	Fixed Feet Housing	IE4 R4SAA			
					Cast Iron Frame	Feet Housing	IE2 S2SAP			
					Cast Iron Frame	Feet Housing	IE3 S3SAP			
	Cooling Tower Motors			Aluminum Frame	Standard Fixed Feet Housing	IE2 S2SSA				
					Standard Fixed Feet Housing	IE3 S3SSA				
					Fixed Feet Housing	IE2 S2SAA				
				Ex-Proof Motors	Cast Iron Frame	Fixed Feet Housing	IE3 S3SAA			
						Feet Housing	IE2 S2TAA			
						Feet Housing	IE3 S3TAA			
	F300 Smoke Extraction Motors		Cast Iron Frame	Ex-Proof Motors	Standard Fixed Feet Housing	IE1 E1SSP				
					Standard Fixed Feet Housing	IE2 E2SSP				
					Without Feet	IE3 D2P3P				
				Standard Fixed Feet Housing	Without Feet	Dual Speed	DVP3P			
					Without Feet	IE1 D1S3P				
					Without Feet	IE2 D2S3P				
			F400 Smoke Extraction Motors	Cast Iron Frame	Standard Fixed Feet Housing	Without Feet	IE3 D3S3P			
						Without Feet	Dual Speed	DVS3P		
						Without Feet	IE2 D2F3P			
					Fixed Feet Housing	Without Feet	IE3 D3F3P			
						Without Feet	Dual Speed	DVF3P		
						Without Feet	IE2 D2P4P			
				Cast Iron Frame	Standard Fixed Feet Housing	Without Feet	IE3 D3P4P			
						Without Feet	Dual Speed	DVP4P		
						Without Feet	IE1 D1S4P			
	Fixed Feet Housing	Without Feet	IE2 D2S4P							
		Without Feet	IE3 D3S4P							
Without Feet		Dual Speed	DVS4P							
Without Feet	IE2 D2F4P									
Without Feet	IE3 D3F4P									
Without Feet	Dual Speed	DVF4P								



”
TECHNICAL
INFORMATION
“

This catalog is prepared to give necessary information on the mechanical and electrical characteristics of 3-phase, cage rotor, fully closed, asynchronous motors manufactured for general use in the industry in accordance with the recommendations of the Turkish Standards Institute "TS" and the International Electrotechnical Commission "IEC".

GAMAK asynchronous motors are designed, manufactured and controlled in accordance with the following standards and recommendations.

TS	IEC	DIN/EN	
TS EN 50347	*60072-1	DIN EN 50437	Dimensions and nominal power of rotary electric machines Foot-Mounted and flange.
TS EN 50347	60072-1	DIN EN 748-1	Cylindrical shaft ends.
TS EN 60034-30-1	60034-30-1	DIN EN 60034-1	Classification and performance.
TS EN 60034-2	60034-2-1	DIN EN 60034-2-1	Methods for experimental assessment of losses and efficiency at rotating electrical machines.
TS 3209	60034-5	DIN EN 60034-5	Enclosure Degree of Protections.
TS EN 60034-6	60034-6	DIN EN 60034-6	Cooling methods.
TS EN 60034-7	60034-7	DIN EN 60034-7	Symbols for frame forms and orders of installation.
TS EN 60034-8	60034-8	DIN EN 60034-8	Marking of the terminals and the direction of rotation.
TS EN 60034-9	60034-9	DIN EN 60034-9	Noise limits.
TS EN 60034-11	60034-11	DIN EN 60034-11	Rules for the protection against heat.
TS EN 60034-12	60034-12	DIN EN 60034-12	Features for start-up.
TS EN 60034-14	60034-14	DIN EN 60034-14	Mechanical vibration: Measuring, evaluating and limits of the intensity.
TS EN 60038	60038	DIN EN 60038	Electric network voltages.
TS EN 60085	60085	DIN EN 60085	Classification of materials used in the insulation of electrical machines according to their thermal stability properties in the workplace.
TS EN 60034-1	60034-1	DIN EN 60034-1	Declared characteristics and operating characteristics of rotary electrical machines.
TS EN 60034-26	60034-26	DIN EN 60034-26	Effects of unbalanced voltages on the performance of three-phase cage induction motors.
TS EN 60072-1	60072-1	DIN 748-1	Induction motors - 3 phase, standard size and output power, general purpose - Frame numbers 56 to 315 and flange numbers 65 to 740.
-	60072-2	DIN 748-1	Induction motors - 3 phase, standard size and output power, general purpose - Frame numbers 355 to 1000 and flange numbers 1180 to 2360.
-	60034-31	DIN IEC 60034-31	Selection of energy saving motors including variable speed applications - Reference guide.
TS EN 60947-8	60947-8	-	Control units for embedded thermal protection (PTC) used in rotating electric machines.

(* IEC 60072-1 defines only the dimensions and nominal power of rotating electric machines Foot-Mounted and flange respectively, but does not establish any relationship between nominal powers and frame sizes. On the other hand, TS EN 50347 and DIN EN 50347 both define the size and nominal power of rotary electrical machines Foot-Mounted and flange according to their structure, and the relationship between them.

Frame, Bearing Carrier Covers and Flanges

The materials used in the motor bodies, bearing carrier covers and flanges are given in the following table according to their size.

Frame Size	Frame	Covers	Flanges		
			B5	B14/Küçük	B14/Büyük
56...100	Aluminum	Aluminum	Aluminum	Aluminum	Aluminum
112	Aluminum	Aluminum	Aluminum	Aluminum	Aluminum
132	Aluminum or Cast Iron	Aluminum or Cast Iron	Aluminum or Cast Iron	Aluminum	Aluminum
160	Aluminum or Cast Iron	Aluminum or Cast Iron	Cast Iron	Cast Iron	Cast Iron
180	Aluminum or Cast Iron	Aluminum or Cast Iron	Cast Iron	-	-
200	Aluminum or Cast Iron	Cast Iron	Cast Iron	-	-
225...450	Cast Iron	Cast Iron	Cast Iron	-	-

Except for aluminum elite motors, all foot mounted motors are cast integrated to the frame. On motors of size 132 ... 180, two lifting eyes are cast integrated to the frame. In addition, a lifting eye in accordance with DIN 580 can be installed optionally on motors with sizes of 160 ... 180.

All motors in sizes 200 to 630 have a lifting eye (DIN 580).

Enclosure Degree of Protections

The degree of protection is indicated with IP and two characteristic numbers, which are the English initials of the words "Ingress Protection", in accordance with TS 3209 EN 60034-5.

Icon	First Digit	Second Digit
	Protection against accidental touch and foreign object ingress	Protection against water
IP 55	Full protection against accidental touches on moving tension parts inside the enclosure.	Protection against damage by water sprayed onto the machine from any direction.
IP 56	Protection against harmful amounts of dust accumulation. Although dust ingress is not completely prevented, the amount of dust that will affect the operation of the motor is prevented from entering the enclosure.	Protection against damage by storm or pressurized water entering the machine and damaging it on the ship deck.

* We produce IP65 and IP66 upon request.

Note: This standard does not cover the special protection degrees required by machines that are intended to be operated in explosive environments and extraordinary operating conditions such as moisture, corrosive vapors, insects and fungi.

GAMAK electric motors are manufactured in accordance with IP 55 protection degree to be able to operate in dusty and humid environments. For this reason, motors can be put into operation in a covered outdoor environment without the need to take any special precautions against mild atmospheric conditions. Motors should be protected against direct sunlight.

However, the necessary protective measures, which are briefly stated below, must be taken against extremely harsh climatic conditions such as working in outdoor environment, humidity at the degree of wetness, corrosive chemical or coastal atmosphere.

- Special protective paint should be used,
- Protection degree IP 56 should be stipulated,
- Winding heads should be protected with a special lacquer against excessive moisture,
- In all kinds of vertical installations open to the atmosphere, the following solutions should be applied in a way that do not interfere with the cooling system of the motor against water leakage into the motor from the shaft ends:
 - Shaft end downwards : The enclosure should be covered with an additional protective cover (canopy),
 - Shaft end upwards : It should be covered with a special protective cover or fitted with a bearing seal.
- The measures to be taken against water condensation are as follows:
The water drain holes covered with plastic plugs are opened at the lowest point of the housing according to the motor's design/installation lay-out and must be kept clean at all times. If the plugs are removed, the degree of protection of the motor enclosure will become IP 44.

However, it is the best method to prevent water condensation by always keeping the internal body temperature of fully enclosed motors at the prescribed level. For this, we recommend the following:

Two heaters with the total power recommended in the table below should be placed on the front and rear winding heads of the motor. However, the heater must be disabled before the motor is started-up.

Recommended Heater Powers:

Frame Size	Heater	
	Voltage V	Power (Total) W
71		16
80...100	110	40
112...180	or	60
200...280	220	80
315...450		120

Another solution is to apply a voltage as low as 5 ... 10% of the motor supply voltage and a current of 20 ... 30% of the rated current to the U1 and V1 terminals by means of an auto-transformer after the voltage feed to the motor is cut off.

Cooling (TS 3210 EN 60 034-6)

Motors with frame size 56 do not have a cooling fan (IC 410) and are cooled by free dispersion. Motors with frame sizes 63 ... 450 are cooled from the outside by a cooling impeller operating in a perforated housing made of steel plate (IC 411). Holes are drilled on the rear surface of the propeller housing in accordance with the conditions of the standard finger test and allowing sufficient air flow. The cooling blades for 63 ... 355 frame size motors are made of high-quality reinforced Polyamide material and for 400 and 450 frame sizes they are made of aluminum alloy. The cooling fan is fixed to the shaft outlet at the rear of the motor and operates regardless of the direction of rotation.

Terminal Box

All terminal boxes are suitable for IP 65 protection degree and are placed on the upper front of the motor and they can be rotated 180° so that the supply cable entry can be made easily from both sides. In general construction, motors have 6 fixed ends and there is a grounding screw in the terminal box in direct contact with the body. The terminal boxes of motors with frame sizes 56 ... 180 are made of high-quality reinforced Polyamide material, and those with frame sizes 200 ... 450 are pressure die-cast aluminum alloy resistant to corrosion. On request, the terminal boxes of motors with frame sizes 71 ... 132 are manufactured from corrosion resistant pressure die-cast aluminum alloy.

Cable Entry

Cable entries into the terminal box are provided by means of fittings manufactured in accordance with EN 60423 and DIN EN 50 262 or by means of waterproof (IP 68) glands upon special request.

Frame Size	Plastic Terminal Boxes					Aluminum Terminal Boxes						
	56-63	71-80-90	100-112	132	160-180	71-80-90-100-112	132	160-180	200-225	250-280-315	355	400*-450*
Cable Entry Gland	M16	M20	M25	M32	M40	M20	M25	M32	M50	M63	PQ70	PQ70
No of Glands	1	1	1	2	2	1	2	2	2	2	2	4
Gland Outer Diameter (mm)	5 - 10	10 - 14	13 - 18	18 - 25	22 - 32	10 - 14	13 - 18	18 - 25	30 - 38	34 - 44	59	59
Largest Total Conductor Cross Section (mm²)	1.5	2.5	2.5	6	16	2.5	6	16	50	120	240	240

Bearings

High quality, sound-controlled fixed ball bearings (DIN 625) or cylindrical roller bearings (DIN 5412) are used in motors.

In GAMAK electric motors, single row fixed ball bearing design is standard. The radial and axial forces that can be carried by the standard design bearings in the bearing arrangement shown in Figures 1, 2, 3 and 4 on the next page are given in the charts on the next page. If the radial force applied to the motor shaft end is higher than the values given on page 22 in motors with frame size 132 and above, a cylindrical roller bearing design with more radial force carrying capacity should be selected (Figure 5). If the axial force applied to the motor shaft end is above the values given in the tables, please consult us as a special design may be necessary.

Standard Design with Fixed Ball Bearing

Frame Size	No of Poles	Front Bearing	Rear Bearing	Table Nr.	Frame Size	No of Poles	Front Bearing	Rear Bearing	Table Nr.	
56	2-4	200 ZZ		1	132	2-4-6-8	6208 C3		4	
63	2-4	6201 ZZ			160	2-4-6-8	6309 C3			
71	2-4-6-8	6202 ZZ			180	2-4-6-8	6310 C3			
80	2-4-6-8	6204 ZZ			200	2-4-6-8	6312 C3			
90	2-4-6-8	6205 ZZ			225	2-4-6-8	6313 C3			
100-112	2-4-6-8	6206 ZZ			250	2-4-6-8	6315 C3			
132	2-4-6-8	6208 ZZ			280	2	6315 C3			
160	2-4-6-8	6309 ZZC3	6209 ZZC3			280	4-6-8	6316 C3		
180	2-4-6-8	6310 ZZC3	6210 ZZC3			315	2	6316 C3		
200	2-4-6-8	6312 ZZC3	6212 ZZC3		2-3	315	4-6-8	6318 C3		
225	2-4-6-8	6313 ZZC3	6213 ZZC3	355		2	6318 C3			
250	2-4-6-8	6315 ZZC3	6215 ZZC3	355		4-6-8	6321 C3			
280	2	6315 ZZ C3		400		2	6318 C3			
280	4-6-8	6316 ZZ C3		400		4-6-8	6324 C3			
				450		2	6320 C3			
				450		4-6-8	6326 C3			

Orders of Bearings

Lubrication Nipples

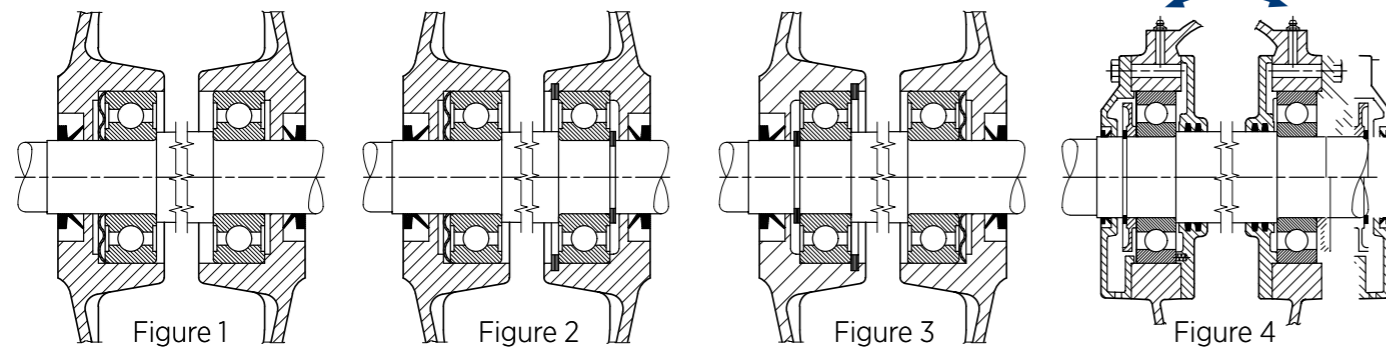

Front Free bearing (Spring must be tensioned)	Rear Free bearing	Front Free bearing (Spring must be tensioned)	Rear Fixed bearing	Front Fixed bearing	Rear Free bearing (Spring must be tensioned)	Front Free bearing (Spring must be tensioned)	Rear Fixed bearing
--	-----------------------------	--	------------------------------	-------------------------------	---	--	------------------------------

- The axial clearance of fixed ball bearing housings is limited by the pre-stressed spring (bearing compression spring - Figures 1, 2, 3) or coil springs (Figure 4). So, bearing vibrations and noise are minimized and bearing life is extended.
- Frame size 56... 132 motors (Table 1) and frame size 160... 280 motors (Tables 2 and 3) use fixed ball bearings closed on both sides (ZZ), lubricated for life by the manufacturer.
- The motors with frame size 56 ... 132 are produced in standard form with ZZ closed bearings with bearing pressure spring at the front as shown in Figure 1 and without locking according to Table 1.
- The motors with frame size 160 ... 280 are produced in standard form with ZZ closed bearings with bearing pressure spring at the front as shown in Figure 2 and with locking according to Table 2 and 3.
- The motors with frame size 315 ... 450 are produced as shown in Figure 4 in standard production with the locking of oil splashing discs at the front and rear and with lubricated bearings, with front and rear locking according to Table 4. Instead of bearing pressure springs of type 315 and above, coil springs are used at the front. The bearings used are open type ball bearings and there are nipples for lubrication during operation.
- According to special customer request, motors with frame size 56 ... 280 are installed in shaft up or down installation positions (V1-V3-V5-V6-V8-V9-V15-V18-V19-V36-V58-V69) in accordance with Table 1, 2 and 3, ZZ closed bearings can be produced with front locking and bearing pressure spring at the back as shown in Figure 3. The purpose here is to prevent the shaft from moving in axial direction when necessary. The bearing arrangement made is expressed as a fixed bearing.
- In line with special customer demand, motors with frame sizes 132... 280 are produced with locking of oil splashing discs at the front and rear and with lubricated bearings as shown in Figure 4, with front and rear locking according to Table 4. The bearing pressure spring used is located at the front.
- Standard motors between 56... 132 types and 280... 450 types are manufactured with the same bearing (in closed ZZ bearing structure or with lubrication). The bearing used at the rear in the same-bearing arrangement is designed to be the same as the one used at the front.
- In line with special customer demands, motors with the same-bearing arrangement can be produced for higher allowable axial forces in motors between 160...250 types.

Reinforced Design with Cylindrical Roller Bearing (For High Radial Forces)

Please consult us if belt/pulley drive is used on motors with frame size 132 and above, as you may need to choose cylindrical roller bearing design.

Frame Size	No of Poles	Front Bearing	Rear Bearing	Table Nr.
132	2-4-6-8	NU 208 E	6208 C3	5
160	2-4-6-8	NU 309 E	6309 C3	
180	2-4-6-8	NU 310 E	6310 C3	
200	2-4-6-8	NU 312 E	6312 C3	
225	2-4-6-8	NU 313 E	6313 C3	
250	2-4-6-8	NU 315 E	6315 C3	
280	2	NU 315 E	6315 C3	
280	4-6-8	NU 316 E	6316 C3	
315	2	NU 316 E	6316 C3	
315	4-6-8	NU 318 E	6318 C3	
355	2	NU 318 E	6318 C3	
355	4-6-8	NU 321 E	6321 C3	
400	2	NU 318 E	6318 C3	
400	4-6-8	NU 324 E	6324 C3	
450	2	NU 320 E	6320 C3	
450	4-6-8	NU 326 E	6326 C3	

**Orders of Bearings
Lubrication Nipples**

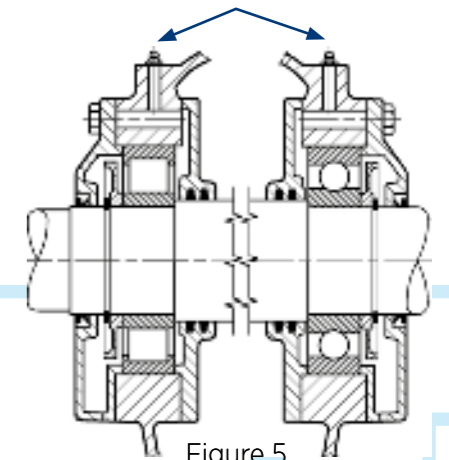

Front
Roller Bearing

Rear
Fixed Bearing

In motors where the design with the cylindrical roller bearing (NU series) is used, there will be slippage between the rolling surfaces of the bearing and the rollers, which will cause the rollers to slide and thus shorten the bearing life, if the radial force is too small during the operation. If the radial force is too small or there is severe shock loads or vibration, so, please consult us as special bearing construction may be necessary. The reinforced design with cylindrical roller bearing is manufactured with lubrication nipple (Figure 5) in motors with frame sizes 132 ... 450. Allowable radial forces are given on page 22, axial forces are given on pages 25-26.

Maintenance of the Bearings

Relubricating Intervals in Lubricated Motors (Hours)

No of Poles	Frame Size					
	132-160	180-200	225-250	280-315	355-400	450
2	5000	4000	3000	2500	2000	2000
4	10000	8000	6000	5000	4000	3000
≥6	15000	12000	9000	7000	5000	4000

The table given above is valid for Gamak motor-lubricated bearings to be used in clean environments, installation of the shaft in horizontal position, -20 / + 40 ° C operating temperature, and <80% relative humidity. The lubrication interval should be halved for vertical running of the motor shaft. Lubrication period should also be halved if the environment is dusty.

Amount of Lubricant for Lubricated Motors (Gram)

No of Poles	Frame Size								
	132	160	180	200	225-250	280	315-355	400	450
2						35	45	50	-
4	10	15	20	25	40	70	90	90	110
≥6									

Depending on the motor structure and operating cycles, the amount of lubrication for each type is specified on the list above.

Allowable Radial Forces

Fr= Radial force (N)
 X = Distance between the shaft step and the force application point (mm).
 Xmax equals to the shaft length The pulley axis should remain within the shaft length.

- P : Motor power (kW)
- n : Speed at full load (RPM)
- D : Pulley diameter (mm)
- k : Belt tension coefficient (approx.)
 - For drive with flat belt and idler pulley: k=2
 - For drive with V-belt: k=2,25
 - For drive with flat belt and multi V-belt without idler pulley: k=3

$$F_r = 1,91 \frac{Pk}{D.n} \cdot 10^7 \text{ (N)}$$

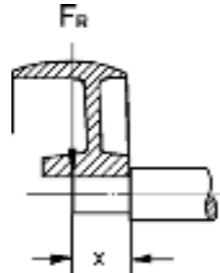

Standard Design with Fixed Ball Bearing (Axial Force Fa = 0)

Frame Size	3000 RPM		1500 RPM		1000 RPM		750 RPM	
	X ₀ N	X _{max} N	X ₀ N	X _{max} N	X ₀ N	X _{max} N	X ₀ N	X _{max} N
56	260	230	330	290	-	-	-	-
63	350	300	450	390	-	-	-	-
71	400	340	510	430	580	490	640	540
80	660	540	840	680	980	800	1070	880
90	740	600	930	760	1070	870	1190	970
100	1040	830	1310	1050	1500	1210	1670	1340
112	1040	840	1300	1050	1490	1210	1650	1340
132	1520	1220	1940	1560	2220	1790	2490	2000
160	2800	2230	3520	2800	4050	3220	4470	3560
180	3230	2630	4090	3330	4710	3830	5180	4210
200	4290	3540	5450	4500	6220	5140	6900	5700
225	4780	3980	6030	4810	6880	5500	7650	6100
250	5800	4730	7330	6000	8420	6870	9230	7540
280	5770	4800	7860	6610	9040	7600	10100	8480
315	6000	5100	8760	7270	9910	8220	11100	9180
355	6700	5800	10400	8620	12300	10100	13700	11300
400	5800	5100	10700	9060	12400	10500	14000	11900
450	*	*	11900	10300	13900	12000	15700	13600

Reinforced Design with Cylindrical Roller Bearing (Axial Force Fa = 0)

Frame Size	3000 RPM		1500 RPM		1000 RPM		750 RPM	
	X ₀ N	X _{max} N	X ₀ N	X _{max} N	X ₀ N	X _{max} N	X ₀ N	X _{max} N
132	3900	3100	4800	3800	5500	4400	6000	4800
160	6890	5490	8480	6750	9620	7660	10500	8370
180	7730	6270	9540	7750	10800	8790	11800	9580
200	10600	8740	13100	10800	14700	12200	16100	13300
225	12600	10500	15600	12400	17600	14000	19300	15400
250	16700	13700	20700	16900	23400	19100	25400	20700
280	16800	14200	22100	18600	25000	21000	27400	23000
315	18000	15500	28900	23700	32600	26800	35600	29200
355	23500	20200	26100	21500	29700	24500	32600	26900
400	22500	19800	36400	30900	41200	35000	44800	38000
450	*	*	40800	35400	46300	40100	50800	44000

* Given upon request.

Frame Size	HORIZONTAL SHAFT					VERTICAL SHAFT									
	Pulling	Pushing			Fr=0	Shaft / Down					Shaft / Up				
		max.F _r		Force Down		Force Up		Force Down		Force Up					
	Fr=0	at X ₀	at X _{max}	at X ₀	at X _{max}	Fr=0	at X ₀	at X _{max}	Fr=0	at X ₀	at X _{max}	Fr=0	at X ₀	at X _{max}	Fr=0
N	N	N	N	N	N	N	N	N	N	N	N	N	N	N	

2 poles (3000 RPM)

56	50	140	120	180	40	40	40	140	130	190	130	120	170	60	60	60
63	80	170	150	220	70	70	70	180	150	230	160	140	210	90	90	90
71	100	190	160	240	90	90	90	200	170	250	170	140	230	110	110	110
80	140	320	270	410	120	120	120	340	280	430	300	250	400	160	160	160
90	160	350	290	430	130	130	130	370	320	470	310	250	410	190	190	190
100	220	490	400	590	170	170	170	520	440	650	430	340	560	270	270	270
112	220	490	410	590	160	160	160	530	450	660	420	340	550	280	280	280
132	350	710	580	820	200	200	200	820	690	1000	530	400	700	500	500	500
160	1650	1090	840	1230	1210	950	1470	1270	1010	1530	790	530	1050	1690	1430	1950
180	1820	1190	920	1300	1250	980	1550	1460	1190	1760	740	460	1030	1980	1710	2270
200	2590	1910	1590	2090	1830	1490	2230	2270	1940	2670	1330	990	1730	2770	2440	3170
225	2820	2070	1730	2260	1920	1560	2390	2510	2150	2970	1360	1000	1830	3070	2710	3530
250	3120	2410	1950	2580	1990	1510	2530	3000	2520	3540	1450	980	1990	3530	3060	4080
280	5200	4420	4040	4670	3710	3280	4420	5250	4810	5950	3180	2740	3880	5780	5350	6490
315	5090	4780	5050	5090	2710	2290	2410	7110	6690	7810	2710	2290	3410	7110	6690	7810
355	5670	5300	5710	5670	2510	2020	3270	8840	8350	9600	-	-	-	-	-	-
400	5080	4790	5100	5080	*	*	*	10850	10440	11670	-	-	-	-	-	-
450	*	*	*	*	*	*	*	*	*	*	-	-	-	-	-	-

4 poles (1500 RPM)

56	50	210	190	260	40	40	40	210	190	270	200	180	260	60	60	60
63	80	270	240	330	70	70	70	270	240	350	260	230	330	90	90	90
71	100	290	250	360	90	90	90	300	260	370	270	230	340	110	110	110
80	140	490	420	610	120	120	120	510	440	640	460	390	590	160	160	160
90	160	540	460	650	120	120	120	570	490	700	490	410	620	200	200	200
100	220	740	630	880	150	150	150	790	680	970	660	540	830	290	290	290
112	220	750	640	870	130	130	130	810	700	980	640	530	810	310	310	310
132	350	1090	920	1240	180	180	180	1210	1040	1450	880	710	1120	520	520	520
160	2110	1510	1180	1690	1540	1200	1880	1740	1400	2090	1120	780	1460	2160	1820	2510
180	2340	1660	1310	1820	1630	1260	2020	1990	1620	2380	1110	740	1500	2510	2140	2900
200	3370	2610	2180	2870	2440	1990	2970	3020	2570	3560	1940	1490	2470	3520	3070	4060
225	3650	2860	2300	3090	2480	1900	3100	3410	2840	4030	1920	1340	2540	3970	3400	4590
250	4060	3290	2680	3520	2610	1980	3340	4010	3380	4740	2080	1450	2800	4550	3920	5270
280	7060	6720	6240	7060	4900	4290	5910	7970	7360	8980	4900	4290	5910	7970	7360	8980
315	7840	7440	7390	7840	4620	3870	5750	10200	9420	11300	4620	3870	5750	10200	9420	11300
355	9410	8950	9700	9410	3870	2910	5330	14600	13600	16100	-	-	-	-	-	-
400	9280	8740	9420	9280	*	*	1760	20500	19600	22100	-	-	-	-	-	-
450	10300	9770	10440	10370	*	*	2400	21900	21000	23600	-	-	-	-	-	-

* For these values, please consult.

Frame Size	HORIZONTAL SHAFT				VERTICAL SHAFT															
	Pulling		Pushing		Shaft / Down						Shaft / Up									
	F _r =0		max.F _r		F _r =0		max.F _r		F _r =0		max.F _r		F _r =0		max.F _r		F _r =0			
	at X ₀		at X _{max}		at X ₀		at X _{max}		at X ₀		at X _{max}		at X ₀		at X _{max}		at X ₀		at X _{max}	
	N	N	N	N	N	N	N	N	N	N	N	N	N	N	N	N	N	N	N	N

6 poles (1000 RPM)

71	100	360	320	450	80	80	80	380	330	470	340	300	430	120	120	120
80	140	630	550	770	110	110	110	660	570	810	590	500	740	170	170	170
90	160	680	580	810	110	110	110	710	610	870	620	520	770	210	210	210
100	220	940	800	1100	140	140	140	1000	850	1200	840	700	1050	300	300	300
112	220	940	810	1090	120	120	120	1010	880	1220	810	680	1010	320	320	320
132	350	1370	1170	1560	150	150	150	1520	1310	1800	1130	920	1410	550	550	550
160	2470	1840	1450	2040	1780	1370	2190	2120	1720	2530	1360	950	1770	2540	2140	2950
180	2730	2010	1590	2210	1910	1480	2380	2360	1930	2830	1400	960	1860	2880	2450	3340
200	3920	3130	2620	3420	2810	2290	3450	3610	3080	4240	2310	1790	2950	4110	3580	4740
225	4240	3450	2800	3680	2810	2120	3540	4160	3470	4890	2250	1560	2980	4720	4030	5450
250	4750	3940	3220	4210	3060	2320	3920	4780	4030	5630	2530	1780	3390	5310	4570	6170
280	8340	7950	7340	8340	5900	5180	7090	9280	8560	10500	5900	5180	7090	9280	8560	10500
315	9170	8700	8790	9170	5260	4380	6600	12200	11300	13500	5260	4380	6600	12200	11300	13500
355	11100	10600	11300	11100	5220	4090	6940	16600	15400	18300	-	-	-	-	-	-
400	11200	10600	11500	11200	1600	*	3500	22700	21700	24600	-	-	-	-	-	-
450	12200	11500	12300	12280	1670	*	3600	25200	24100	27200	-	-	-	-	-	-

8 poles (750 RPM)

71	100	420	370	520	80	80	80	440	390	540	400	350	500	120	120	120
80	140	730	630	880	110	110	110	750	650	920	680	590	860	170	170	170
90	160	800	690	950	110	110	110	830	720	1010	740	620	920	210	210	210
100	220	1100	940	1300	140	140	140	1160	1000	1400	1000	840	1240	300	300	300
112	220	1100	940	1270	120	120	120	1170	1020	1400	970	810	1200	320	320	320
132	350	1610	1380	1850	180	180	180	1740	1500	2070	1390	1160	1720	520	520	520
160	2760	2090	1640	2340	2020	1570	2480	2360	1910	2820	1600	1150	2060	2780	2330	3240
180	3040	2290	1820	2520	2130	1640	2650	2680	2190	3200	1610	1130	2130	3200	2710	3720
200	4410	3550	2970	3910	3230	2630	3940	4020	3430	4730	2730	2130	3440	4520	3930	5230
225	4780	3870	3130	4220	3320	2550	4140	4510	3750	5340	2760	1990	3580	5070	4310	5900
250	5290	4440	3640	4750	3430	2600	4390	5340	4500	6300	2900	2060	3860	5880	5040	6840
280	9480	8990	8230	9480	6930	6120	8280	10200	9390	11600	6930	6120	8280	10200	9400	11600
315	10400	9880	9790	10400	6350	5360	7860	13300	12300	14800	6350	5360	7860	13300	12300	14800
355	12700	12100	12600	12700	6580	5310	8510	17900	16600	19800	-	-	-	-	-	-
400	12600	12000	12900	12600	2430	1200	4540	25000	23700	27100	-	-	-	-	-	-
450	14100	13300	14200	14100	3330	2100	5500	26800	25700	29000	-	-	-	-	-	-

Frame Size	HORIZONTAL SHAFT				VERTICAL SHAFT															
	Pulling		Pushing		Shaft / Down						Shaft / Up									
	F _r =0		max.F _r		F _r =0		max.F _r		F _r =0		max.F _r		F _r =0		max.F _r		F _r =0			
	at X ₀		at X _{max}		at X ₀		at X _{max}		at X ₀		at X _{max}		at X ₀		at X _{max}		at X ₀		at X _{max}	
	N	N	N	N	N	N	N	N	N	N	N	N	N	N	N	N	N	N	N	N

2 poles (3000 RPM)

132	1370	1100	750	1370	960	620	1290	1200	850	1520	960	620	1290	1200	850	1520
160	2450	2040	1440	2450	1740	1140	2270	2220	1620	2750	1740	1140	2270	2220	1620	2750
180	2820	2400	1780	2820	1750	1330	2550	2680	2050	3280	1950	1330	2550	2680	2050	3280
200	3710	3160	2380	3710	2570	1790	3350	3520	2730	4290	2570	1790	3350	3520	2730	4290
225	4150	3480	2590	4150	2770	1870	3720	3920	3020	4870	2770	1870	3720	3920	3020	4870
250	5000	4150	2880	5000	3200	1920	4410	4750	3460	5960	3200	1920	4410	4750	3460	5960
280	5180	4080	2950	4650	3230	2090	4330	4940	3790	6040	2700	1550	3800	5470	4330	6570
315	5180	5010	3910	5180	2770	1650	3790	6420	5300	7430	2770	1650	3790	6420	5300	7430
355	5670	5660	4620	5670	2150	690	3270	8470	7020	9600	-	-	-	-	-	-
400	5090	5270	5270	5090	*	*	*	10370	9150	11670	-	-	-	-	-	-
450	*	*	*	*	*	*	*	*	*	*	-	-	-	-	-	-

4 poles (1500 RPM)

132	1820	1500	1040	1820	1280	830	1700	1610	1160	2020	1280	830	1700	1610	1160	2020
160	3240	2720	1940	3240	2320	1540	3010	2950	2160	3640	2320	1540	3010	2950	2160	3640
180	3760	3200	2390	3760	2650	1830	3440	3530	2710	4310	2650	1830	3440	3530	2710	4310
200	4950	4200	3180	4950	3530	2500	4550	4610	3580	5630	3530	2500	4550	4610	3580	5630
225	5520	4650	3250	5520	3710	2300	4960	5210	3800	6460	3710	2300	4960	5210	3800	6460
250	6640	5540	3880	6640	4340	2660	5930	6270	4600	7860	4340	2660	5930	6270	4600	7860
280	7100	6200	4630	7100	4440	3130	6040	7270	5960	8870	4440	3130	6040	7270	5960	8870
315	7840	7340	5220	7840	3910	1770	5750	9460	7320	11300	3910	1770	5750	9460	7320	11300
355	9410	9540	7920	9410	3280	1200	5330	14000	11900	16100	-	-	-	-	-	-
400	9220	9600	9700	9220	*	*	1760	19600	17100	22100	-	-	-	-	-	-
450	10370	10620	10800	10350	*	*	2400	21100	18600	23600	-	-	-	-	-	-

6 poles (1000 RPM)

132	2160	1770	1250	2160	1550	1030	2040	1890	1390	2380	1550	1030	2040	1890	1390	2380
160	3840	3240	2320	3840	2760	1830	3570	3520	2600	4330	2760	1830	3570	3520	2600	4330
180	4460	3790	2850	4460	3180	2230	4100	4150	3190	5070	3180	2230	4100	4150	3190	5070
200	5820	4960	3780	5820	4150	2950	5340	5450	4250	6640	4150	2950	5340	5450	4250	6640
225	6500	5530	3900	6500	4330	2680	5800	6240	4590	7710	4330	2680	5800	6240	4590	7710
250	7860	6580	4640	7860	5170	3210	7030	7420	5460	9280	5170	3210	7030	7420	5460	9280
280	8390	7320	5460	8390	5370	3490	7230	8490	6610	10400	5370	3490	7230	8490	6610	10400
315	9170	8740	6270	9170	4440	1920	6600	11300	8830	13500	4440	1920	6600	11300	8830	13500
355	11100	11300	9300	11100	4540	2110	6940	15900	13400	18300	-	-	-	-	-	-
400	11200	11700	11100	11200	*	*	3500	21700	18800	24600	-	-	-	-	-	-
450	12280	12570	12700	12300	*	*	3600	24100	21300	27000	-	-	-	-	-	-

Frame Size	HORIZONTAL SHAFT				VERTICAL SHAFT											
	Pulling		Pushing		Shaft / Down						Shaft / Up					
	max.F _r		F _r =0		Force Down			Force Up			Force Down			Force Up		
	F _r =0	at X ₀	at X _{max}	F _r =0	max.F _r	at X ₀	at X _{max}	F _r =0	max.F _r	at X ₀	at X _{max}	F _r =0	max.F _r	at X ₀	at X _{max}	F _r =0
N	N	N	N	N	N	N	N	N	N	N	N	N	N	N	N	N

8 poles (750 RPM)

132	2450	2000	1400	2450	1790	1200	2340	2090	1500	2650	1790	1200	2340	2090	1500	2650
160	4340	3640	2620	4340	3150	2130	4060	3910	2890	4820	3150	2130	4060	3910	2890	4820
180	5010	4270	3210	5010	3590	2530	4620	4660	3590	5690	3590	2530	4620	4660	3590	5690
200	6580	5590	4260	6580	4770	3430	6110	6070	4730	7410	4770	3430	6110	6070	4730	7410
225	7360	6180	4370	7360	5080	3240	6720	6830	4990	8480	5080	3240	6720	6830	4990	8480
250	8800	7370	5220	8800	5830	3660	7910	8270	6100	10400	5830	3660	7910	8270	6100	10400
280	9510	8210	6140	9510	6310	4210	8400	9340	7240	11500	6310	4210	8400	9340	7240	11500
315	10400	9760	7000	10400	5440	2630	7860	12300	9540	14800	5440	2630	7860	12300	9540	14800
355	12700	12800	10300	12700	5830	3120	8510	17200	14400	19800	-	-	-	-	-	-
400	13000	13400	12200	13000	2000	*	5230	23100	19900	26400	-	-	-	-	-	-
450	14100	14400	14000	14100	*	*	5500	25800	22500	29000	-	-	-	-	-	-

- All values are:
 - Based on L10 bearing shelf-life of at least 20,000 hours.
 - For 50 Hz frequency.
- For 60 Hz network, please consult.

Shaft End

In our standard production, the shaft end of the motors is single-sided and is fitted with an appropriate wedge (TS EN 50 347 / IEC 60 072-1). In addition, a thread in accordance with DIN 332-2 shape "D" is tapped on the shaft end. Upon request, motors can be manufactured with shaft ends on both sides. The shaft end runoff, the concentricity of the flange step and the perpendicularity of the surface are within the normal class limits specified in TS EN 50 347 / IEC 60 072-1. Upon request, manufacturing can also be made within the tolerance of "Sensitive Class".

Vibration

the HALF WEDGE placed on the shaft end. For this reason, the pulley, gear, coupling etc. that are attached to the shaft end of the motor, the dynamic balance of the transmission elements and the fan should be made on a straight mandrel before the key way is opened.

Noise Level

The limits of the noise level in general purpose electrical machines are specified in TS EN 60034-9. The noise level in GAMAK electric motors is well below the specified limits. There are 3 main sources of noise:

- 1. Magnetic forces:** They force the stator package to vibrate in the radial direction.
- 2. Bearings:** Balls and rollers make noise due to geometrical structural defects.
- 3. Cooling fan:** It makes the noise called ventilation sound.

The most powerful of these 3 main sources of noise is usually the fan. This is particularly evident in large motors. Special measures can be taken to reduce noise on request. Noise in the air is detected in a soundproof and anechoic test room in accordance with DIN EN 21 680-1. The surface sound pressure level (L_{pfA}) in dB (A) unit is the average of the sound pressure values read on the "A" scale of the sound measuring device in measurements made at different locations 1 m from the motor surface. Tolerance +3dB (A). The values below are valid for 50 Hz network frequency. For 60 Hz, values increase by about 4dB (A).

Surface Noise - Pressure Level (L_{pfA})

Frame Size	2 poles dB(A)	4 poles dB(A)	6 poles dB(A)	8 poles dB(A)
56	44	44	-	-
63	54	43	-	-
71	54	46	42	43
80	56	50	47	48
90	62	54	48	48
100	64	55	52	52
112	66	56	56	54
132	68	61	60	58
160	70	64	63	61
180	72	64	64	62
200	74	66	64	63
225	76	66	65	63
250	76	67	66	64
280	76	70	67	66
315	79	75	72	70
355	83	76	75	71
400	82	78	76	71
450	84	78	76	74

* Please consult for these values.

Painting

High efficiency (IE2) motors are RAL 7031 (DIN 1843) gray colored, and Premium efficiency (IE3) and these motors are blue colored RAL 5007 (protective paint). This conforms to ISO 12944 C3M class. On request, a special exterior paint, resistant to excessively humid atmosphere, chemicals and micro-organisms, can be applied. Different color, different category (C4, C5) options are evaluated upon request.

Storage

If the motors are to be stored for a long time, they must be kept in moisture-free, vibration-free, clean and well-ventilated places, and the insulation resistance must be measured before they are put into service and the windings must be dried if necessary.

Frame Forms and Installation Arrangements (TS 3211 EN 60 034-7)

Foot-Mounted

Figure	Icon	Description	Frame Size
	IM B3 IM 1001	Floor mounted.	56...450L
	IM B6 IM 1051	Wall mounted. Seen from the drive side foot mounted on the left.	56...315M
	IM B7 IM 1061	Wall mounted. Seen from the drive side foot mounted on the right.	56...315M
	IM B8 IM 1071	Ceiling mounted.	56...315M
	IM V5 IM 1011	Wall mounted. Shaft end downwards.	56...315M
	IM V6 IM 1031	Wall mounted. Shaft end downwards.	56...315M

Foot-Mounted, with Flange

Figure	Icon	Description	Frame Size
	IM B35 IM 2001	Floor mounted, flanged connection. Flange form A, "FF"	56...450L
	IM V15 IM 2011	Wall mounted, flanged connection, Flange form A, "FF" Shaft end downwards.	56...315L
	IM V36 IM 2031	Wall mounted, flanged connection, Flange form A, "FF" Shaft end upwards.	56...315M
	IM B34 IM 2101	Floor mounted, flanged connection. Flange form C, "FT"	56...160L
	IM V58 IM 2111	Wall mounted, flanged connection, Flange form C, "FT" Shaft end downwards.	56...160L
	IM V69 IM 2131	Wall mounted. Flanged connection. Flange form C, "FT" Shaft end upwards.	56...160L

Without Foot, With Flange

Figure	Icon	Description	Frame Size
	IM B5 IM 3001	Flange mounted. Flange form A, "FF"	56...315M
	IM V1 IM 3011	Flange mounted at the bottom. A, "FF" Shaft end downwards.	56...450L
	IM V3 IM 3031	Flange mounted at the top. Flange form A, "FF" Shaft end upwards.	56...315M
	IM B14 IM 3601	Flange mounted. Flange form C, "FT"	56...160L
	IM V18 IM 3611	Flange mounted at the bottom. Flange form C, "FT" Mill Shaft end downwards.	56...160L
	IM V19 IM 3631	Flange mounted at the top. Flange form C, "FT" Shaft end upwards.	56...160L

Without Foot, Without Front Cover (Pad Mounted)

Figure	Icon	Description	Frame Size
	IM B9 IM 9101	Frame mounted at the front end.	56...315M
	IM V8 IM 9111	Frame mounted at the front end. Shaft end downwards.	56...450L
	IM V9 IM 9131	Frame mounted at the front end. Shaft end upwards.	56...315M

Foot mounted, without Front Cover

Figure	Icon	Description	Frame Size
	IM B15 IM 1201	Floor mounted connected from frame front.	56...450L

Without Foot, with Front Cover (Pad Mounted)

Figure	Icon	Description	Frame Size
	IM B30 IM 9201	4 separate points on the frame.	80-100L

Voltage and Frequency

The motors are manufactured as standard according to 400 V rated voltage and 50 Hz frequency, upon request, production can be made for voltages up to 110 ... 660 V and frequencies 50-60 Hz. Variations of ± 5% in nominal voltage and ± 2% in frequency practically do not cause any change in motor power. The temperature of motors continuously operating at the lower and upper limit values of the allowable voltage variation may exceed the allowable temperature rise limit by maximum 10K according to the winding insulation class. Motors manufactured according to a frequency of 50 Hz frequency can usually be connected to a network with 60 Hz frequency. In this case, the catalog values are multiplied by the approximate coefficients given in the chart to find new operating values at various voltages.

50 Hz	60 Hz								
	Network voltage V	Power	Speed	I _N	M _N	I _A /I _N	M _A /M _N	M _K /M _N	I ₀
230	230	1	1,2	1	0,83	0,87	0,75	0,85	0,73
	*230	1,15	1,2	1,15	0,96	0,98	0,93	1	1,12
	250	1,1	1,2	1	0,91	0,96	0,83	0,94	0,85
	264	1,15	1,2	1	0,96	1	0,93	1	0,93
400	400	1	1,2	1	0,83	0,87	0,75	0,85	0,73
	*400	1,15	1,2	1,15	0,96	0,98	0,93	1	1,12
	440	1,1	1,2	1	0,91	0,96	0,83	0,94	0,85
	460	1,15	1,2	1	0,96	1	0,93	1	0,93
415	480	1,2	1,2	1	1	1,03	0,98	1,03	0,98
	415	1	1,2	1	0,83	0,87	0,75	0,85	0,73
	*415	1,15	1,2	1,15	0,96	0,98	0,93	1	1,12
	460	1,1	1,2	1	0,92	0,98	0,90	0,96	0,87
500	480	1,15	1,2	1	0,96	1	0,93	1	0,93
	500	1	1,2	1	0,83	0,87	0,75	0,85	0,73
	*500	1,15	1,2	1,15	0,96	0,98	0,93	1	1,12
	550	1,1	1,2	1	0,92	0,98	0,90	0,96	0,87
600	575	1,15	1,2	1	0,96	1	0,93	1	0,93
	600	1,2	1,2	1	1	1,03	0,98	1,03	0,98

*Special winding for 60 Hz.

I_N: Nominal Current I₀: Current Under No Load M_A: Start-up Torque I_A: Start-up Current M_N: Nominal Torque M_K: Overturning Torque

The following standard powers should be taken as basis in the selection of motors specially wound for conformance to 60 Hz network. Depending on the power and speed of the motors, it is possible to increase the power by up to 20%. Therefore, please consult for higher power demands than the powers listed in the below table.

Standard Power at 50 Hz (kW)	Standard Power at 60 Hz (kW)	Standard Power at 50 Hz (kW)	Standard Power at 60 Hz (kW)	Standard Power at 50 Hz (kW)	Standard Power at 60 Hz (kW)
0,06	0,07	4	4,6	90	103
0,09	0,105	5,5	6,3	110	126
0,12	0,14	7,5	8,6	132	152
0,18	0,21	11	12,7	160	184
0,25	0,29	15	17,3	200	230
0,37	0,43	18,5	21,3	250	288
0,55	0,63	22	25,3	315	360
0,75	0,86	30	34,5	355	410
1,1	1,27	37	42,6	400	460
1,5	1,73	45	51,8	450	515
2,2	2,5	55	63,5	500	575
3	3,5	75	86,5		

Please consult for the power values to be obtained in the special winding above 500 kW rated power and 60 Hz.

According to the IEC 60034-30 standard, efficiency values are assessed separately for each power rate for 50Hz and 60Hz operation. Please consult for the efficiency values the motors will have in case they are wound for 50Hz and operated at 60Hz or specifically wound for 60Hz.

Nominal Power

The nominal power is the mechanical power specified on the plate of the P_N motor given to the shaft at nominal values. The effective power P₁ is the power drawn by the motor from the network, and it is greater than the mechanical power output on the shaft due to losses. $P_1 (W) = \sqrt{3} \cdot U \cdot I \cdot \cos \Phi$
 Efficiency (η) is the division of the mechanical power to the effective power. The efficiency values given in the catalog are calculated by the method of summing up the losses according to IEC 60 034-2-1: 2014. (For more details, see page 36). The nominal powers given in this catalog are the mechanical powers delivered by the motor shaft at nominal voltage and frequency, at 40°C ambient temperature, at locations up to 1000 m above sea level and in continuous operation (S1) type. When standard GAMAK motors manufactured in F insulation class are operated at ambient temperatures above 40°C and at places higher than 1000 m altitude, their nominal power changes at the following rates:

Ambient Temperature	°C	<30	30..40	45	50	55	60	Height	m	1000	2000	3000	4000
Nominal Power	%	107	100	95	90	85	80	Nominal Power	%	100	95	90	80

If the ambient temperature and altitude both change together, multiply the rated power by the coefficients of altitude and temperature to find the new allowable power. If the power reduction exceeds 15%, the running characteristics of the motor will be unfavorable due to the low usage factor. In this case, please consult us. At altitudes above 1000 m, if the ambient temperature of 35°C decreases by the following amounts for every 100 m height increase, the nominal power will not change.
 1.0°C for insulation class F
 1.25°C for insulation class H

Overloadability

If excessive current of 1.5 times the nominal current passes at intervals of 15 minutes and for 2 minutes from a standard asynchronous motor operating at a regime temperature of 1.0°C for insulation class H, and 1.25°C for insulation class H, there will not be any temperature rise that will damage the motor windings. Standard asynchronous motors can withstand instantaneous excessive torques up to 1.6 times the nominal torque for 15 seconds while operating at their nominal voltage and frequency. Longer overloads than described above depend on the size of the motor and the temperature rise characteristic, the duration and frequency of the overload, and the application of the overload when the motor is running at cold or regime temperature.

Nominal Torque

The torque delivered by the motor shaft:
$$\frac{\text{Nominal Power (kW)}}{\text{Nominal speed (RPM)}}$$

Nominal torque (Nm) = 9550

1 kgf m = 9,81 Nm - 10 Nm

Motor torque at start-up must always be higher than the counter torque of the driven machine.

Insulation Class

In our standard production, motors are insulated in Class F up to 315 Type, in Class H at 315 and above. Although the allowable temperature rise limit of Class F with the resistance method is 105K, GAMAK motors are designed to operate within the Class B limit (80K) to have a longer life and better performance. This allows motors up to 160 (included) frame size to withstand ambient temperatures of 60°C and larger ones up to 55°C, or alternatively, their power can be increased by 15% and 10% respectively, or they can withstand the harsh conditions in the supply voltage. Upon request, motors are produced in a higher insulation class, Class H (125K). The round copper enameled coil wire used in our standard production is produced with two layers (2L) of enamel. The first layer is enameled with polyesterimide in "H" (180°C) thermal class, and the second layer with polyamide in "N + C" (200°C) thermal class.

Motor windings are dipped in an H class synthetic varnish (polyester) to increase resistance to vibration and provide a superior heat permeability, and then baked and dried. The windings of the motors we manufacture as standard are insulated in accordance with tropical climate conditions. Thus, they can be used in places with medium humidity other than normal climatic conditions as well as resistant to aggressive gases, steam and oily environments. On request, winding insulation is made to withstand 95% relative humidity.

Types of Operation

The operating regime is a working program that includes the periods and sequence of application of the loads applied to the motor together with the periods of idle running and stopping. The type of operating regime is the order of the motor operating with one or more specific loads that do not change in specified periods. Electric motors are manufactured for a wide variety of operating conditions. Standard operating regime types are classified in TS 3067 / IEC 60 034-1.

S1: Continuous Operation

Operation of the motor under constant load until thermal stability is reached.

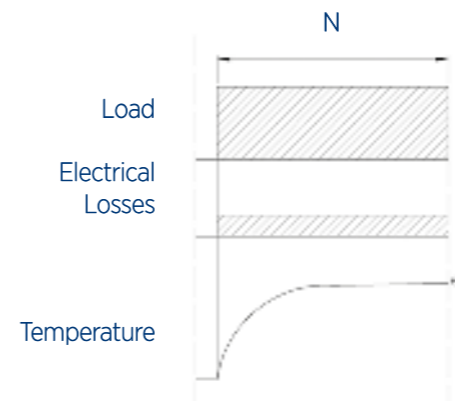

S2: Short Continuous Operation

The running of the motor under constant load for a period not sufficient to reach thermal stability and then stopping until it cools down to ambient temperature. Operating time is recommended to be 10, 30, 60 and 90 minutes.

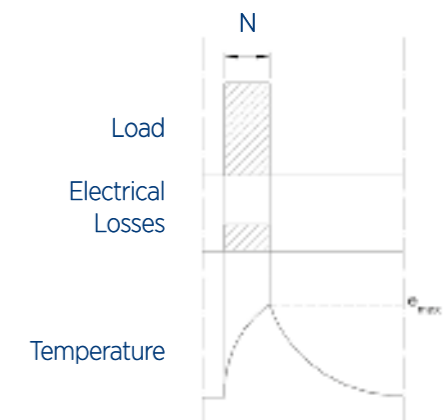

S3: Intermittent Operation at Intervals

It consists of the same set of working periods. Each period has two parts; the first part is working under constant load, the other is to stop. Start-up current does not cause an increase in temperature. The operating period is 10 minutes unless otherwise agreed. Relative operating time is predicted as 15%, 25%, 40% and 60% of a period.

AN OPERATING PERIOD

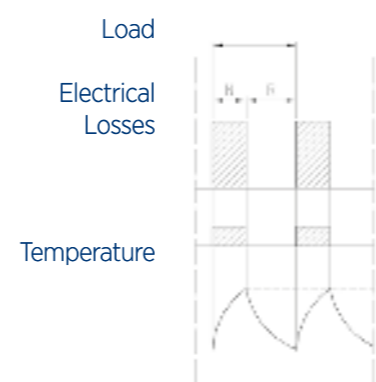

S4: Intermittent Operation at Intervals With Start-ups

It consists of the same set of working periods. Each period consists of a long enough start-up period to cause a temperature increase, operation under constant load and a stopping period. The operating periods are too short for the motor to reach thermal equilibrium. The start-up load torque (N), the number of start-ups per hour, relative operating time as a percentage and the coefficient for the Torque of inertia should be given.

AN OPERATING PERIOD

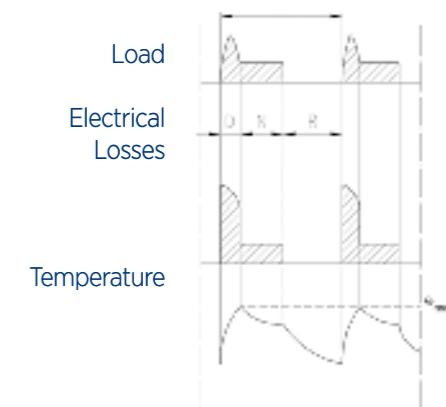

S5: Intermittent Operation at Intervals and Electrical Braking

It consists of the same set of working periods. Each period consists of a long enough start-up, running under constant load, instantaneous electrical braking and stopping. Load torque (N) at start-ups/brakes, number of start-ups/brakes per hour, relative running time in percentage and coefficient for Torque of inertia Torque should be given.

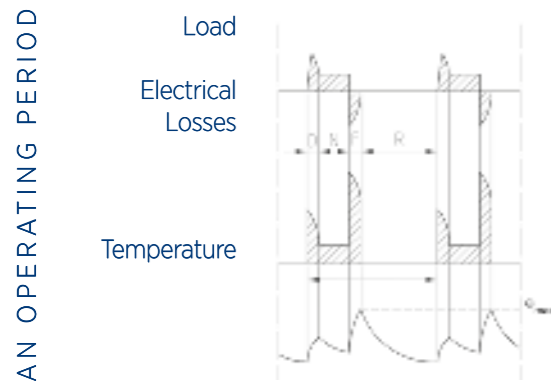

S6: Continuous Operation at Intervals

It consists of the same set of working periods. Each period has two parts; the first part is to run under constant load, the other is to run unloaded. There are no stops in this type of operation. Running periods are too short to reach thermal stability. The operating period is 10 minutes unless otherwise agreed. Relative operating time is predicted as 15%, 25%, 40% and 60% of a period.

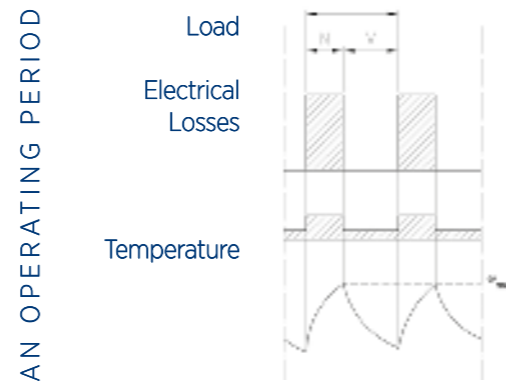

S7: Continuous Operation with Electrical Braking

It consists of the same set of working periods. Each period consists of a long enough start-up period, constant load operation and electrical braking to cause a temperature increase. There is no stopping in this type of operation. Working periods are too short to achieve thermal equilibrium. Load and inertia torque coefficient should be given during the working period.

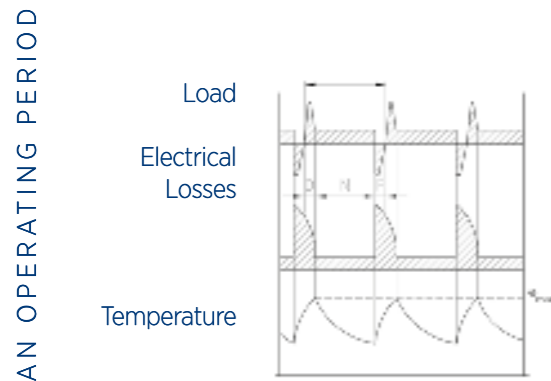

S8: Period Load-Speed Commutative Operation

It consists of the same set of working periods. Each period consists of operating under a fixed load at a predetermined speed, followed by operating under one or more other fixed loads at different speeds. There is no stopping in this type of operation. Operating periods are too short to achieve thermal equilibrium. For each speed in the operating period, load and relative operation times and the coefficient for the torque of inertia should be given.

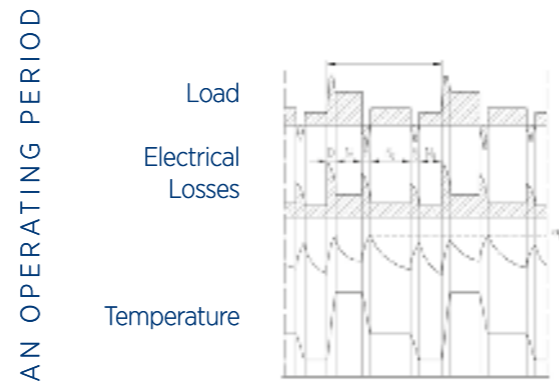

S5: S9: Non-Periodic Load-Speed Variable Operation

Load and speed change non-periodically within a defined operating range. In this type of operation, there are usually overloads above the motor's nominal power. Load and coefficient for Torque of inertia each speed must be given.

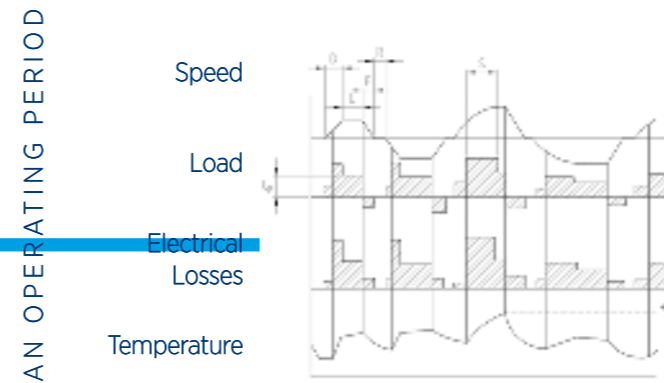

- N : Operation under nominal conditions
- D : Start-up
- F : Electrical braking
- L : Operation under variable loads
- R : Stop
- V : Idling
- S : Operation under overload
- Cp : Full load

Relative operating time: It is the ratio of the operating time of the motor at load, including the start-up and electrical braking periods, expressed as a percentage of the period duration.

$$\text{Coefficient for the Torque of inertia} = \frac{J_M / J_Z}{J_M}$$

- J_M : Torque of Inertia of the motor (kgm²).
- J_Z : Total Torque of inertia of the work machine and fittings such as the coupling relative to the motor shaft (kgm²).

It should also be noted that the type of braking is mechanical or electrical [direct current braking or alternating current braking (by changing the direction of rotation of the motor)].

The operating values given in the catalog belong to the continuous operation (S1) type. However, the S1 type motors that we manufacture as a standard can work in all other operating types, provided that they do not exceed the allowable maximum temperature.

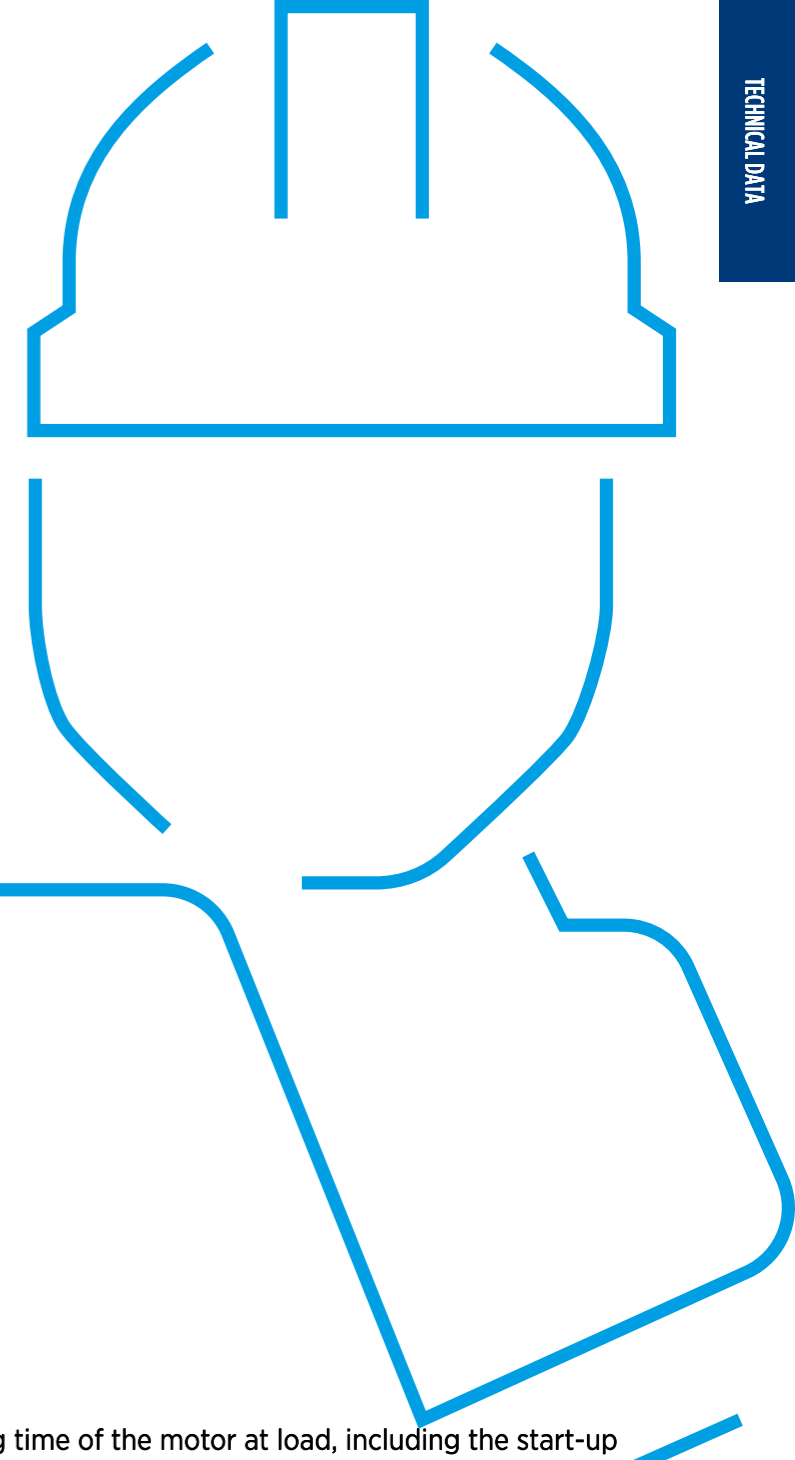

Start-up Frequency

If an asynchronous motor starts up frequently, the start-up warm-up limits the number of start-ups that can be made in a given period of time. Permissible start-up frequency values (z0) per hour in idle operation are given in the table below for GAMAK motors. The number of start-ups (z) that an asynchronous motor can make per hour depends on the operating conditions and is calculated according to the following formula.

$$z = \frac{J_M}{J_M + J_Z} \cdot \frac{M_M - M_L}{M_M} \cdot \left[1 - \left(\frac{P}{P_N} \right)^2 \right] \cdot z_0$$

- z : Start-up frequency per hour under given operating conditions.
- z₀ : Frequency of start-ups per hour in idling (given in the chart).
- J_M : Torque of Inertia of the motor (kgm²).
- J_Z : Total Torque of inertia of the work machine and fittings such as the coupling relative to the motor shaft (kgm²).
- M_M : Motors average torque during acceleration (Nm).
- M_L : Average torque of the work machine during acceleration (Nm).
- P_N : Motor nominal power (kW).
- P : The power required by the work machine (kW).

If an asynchronous motor starts and stops frequently under operating conditions, the allowable motor power P is smaller than the nominal power PN and is calculated according to the formula below.

$$P = P_N \sqrt{1 - \frac{z}{z_0} \cdot \frac{J_M + J_Z}{J_M} \cdot \frac{M_M}{M_M - M_L}}$$

For GAMAK motors, MM can be taken about twice the motor nominal torque. The electrical direction change generates about 3.5 ... 4 times the heat from the take-off, so one change of direction equals about 4 starts. For this reason, the allowable frequency of direction change per hour is assessed by dividing the departure frequency into 4. However, the load torque ML is not taken into account in the direction change calculations.

Allowable Start-up Frequency per Hour at Idle (Z₀)

Frame Size	Motor speed (RPM)			
	3000	1500	1000	750
*56	12200	21100	-	-
63	31000	49000	-	-
71	15700	21700	32000	35000
80	9800	18500	29000	33000
90	S	9400	17500	26600
	L	9100	16800	24500
100	L	6600	11200	14000
112	M	3500	9400	13000
132	S	2200	5100	10000
	M	-	4900	8000
160	M	1100	3100	4200
	L	1050	3000	3700
180	M	700	2200	-
	L	-	2100	3500
200	L	520	2000	3200
225	S	-	1900	-
	M	450	1800	2300
250	M	350	1000	1900
280	S	230	740	1500
	M	210	700	1200
315	S	140	460	840
	M	120	420	700
	L	100	370	600
355	M	60	180	300
	L	50	160	250
400	L	**	140	200
450	L	**	120	150

* There is no cooling fan (IC 410 / IEC 60 034-6). ** Please consult for these values.

Start-up Time

For the safe start-up of an asynchronous motor, during acceleration the motor torque must be large enough than the load torque of the work machine at each speed. In particular, the start-up torque of the motor must be greater than the load torque of the work machine at standstill. Special rotors that increase motor start-up torques can be made for drives with high load torques during acceleration.

The start-up time is a very important factor in the operating behavior of the electric motor. Since each start heats up the asynchronous motor with cage rotor, it is necessary to limit the start-up time and frequency in order not to damage the motor. The calculation of the departure time is generally complicated. In the first approach, the following formula can be applied.

$$t_a = \frac{(J_M + J_Z) \cdot n}{9,55 \cdot (M_M - M_L)}$$

- t : Start-up-up Time (s)
- J_M : Torque of Inertia of the motor (kgm²)
- J_Z : Total Torque of inertia of the work machine and fittings such as the coupling relative to the motor shaft (kgm²)
- n : Motor operation speed (RPM)
- M_M : Motors average torque during acceleration (Nm)
- M_L : Average torque of the work machine during acceleration (Nm)

If the start-up time obtained from this way is less than the allowable values in the chart for GAMAK motors, there is no problem in terms of heating of the motor at this start-up. The allowable values of the start-up time depends on whether the motor starts-up in cold or at the operating temperature. In cases where the calculated start-up time exceeds the allowable value, measures can be taken to facilitate the start-up or a motor selection with more suitable start-up features can be chosen. In drives where the load torque increases with the square of the speed and the torque of inertia is not too high, a cage rotor induction motor can usually start up in a cold state 3 times and at operating temperature 2 times consecutively. For the next start-up, it is necessary to wait until it cools down (about half an hour). In this case, please consult us.

Allowable Start-up Time at Direct Start (S)

Frame Size	Motor Speed (RPM)							
	3000		1500		1000		750	
	When Cold	At Operating Temperature	When Cold	At Operating Temperature	When Cold	At Operating Temperature	When Cold	At Operating Temperature
56	90	35	180	75	-	-	-	-
63	70	28	100	45	-	-	-	-
71	50	20	75	30	140	55	140	55
80	40	15	60	25	90	35	90	35
90	35	13	50	20	65	25	65	25
100	32	12	40	17	50	20	50	20
112	30	11	35	14	40	16	40	16
132	28	10	30	12	32	13	32	13
160	26	9	27	10	28	10	28	10
180	24	8	25	9	25	9	25	9
200	22	8	23	8	23	9	23	9
225	20	7	21	8	22	8	22	8
250	19	7	20	7	21	8	21	8
280	18	6	19	7	20	7	20	7
315	18	6	18	6	19	7	19	7
355	16	5	16	5	17	6	17	6
400	*	*	14	4	15	5	15	5
450	*	*	14	4	15	5	15	5

Y/Δ The time for start-up is three times the time for direct start given above.
* Please consult for these values.

The easiest way to start a caged asynchronous motor is to connect the motor to the network directly. The required start-up equipment is only a direct starter. In this most preferred method, attention should be paid to the rules and limitations of electrical administrations due to the high start-up current.

No of Poles	Limits of nominal power (kW) at 400 V, 50 Hz	
	220-240 V (Δ) / 400 V (Y)	400 V (Δ)
2 and 4	≤3 kW	≥ 3,7kW
6	≤2,2 kW	≥ 3kW
8	≤1,5 kW	≥ 2,2kW
Methods for start-up	Direct	Y / Δ or others

Indirect Start

Star-delta start can be used if the start-up current of the motor is greater than the mains limit value. In delta connection, a motor that is wound according to the mains phase-phase voltage (e.g. 380V, 400V) is started in star connection. In this method, the start-up current and torque decrease to approximately 1/3 of the direct start-up value. In order to limit the current and torque pulses in the transition from star to delta, the transition should be made as close as possible (93 ... 95%) to the motor nominal speed. However, it is possible to reduce the high start-up current of large motors a little more by connecting star-delta (Y / Δ / Δ).

Soft Start

In some cases, motors are required to start softly, the start-up current is not important. A soft starter can then be used. In this way, the start-up time can be adjusted according to a soft start and the motor operation can be adjusted according to the requirement of the voltage by continuously monitoring, thus minimizing the losses. When using a soft starter, the torque curve of the motor must match the characteristics of the driven machine.

Electrical Protection of Motors

Winding temperatures in motors should not exceed the defined values. Therefore, the thermal protection of the windings should be selected in a way that best suits the operating conditions. Generally, motors are protected by bimetallic mechanism circuit breakers or overload relays that provide delayed overcurrent protection. However, this protection is particularly effective during the start-up process. Furthermore, motors are protected against excessive temperature increases that may occur due to any reason by means of thermostats, which are bimetal switches, thermistors and semiconductor temperature sensors, placed in the windings. Since thermistor protection controls the temperature in the winding, which is the most critical point, it is safer than other motor protection systems regardless of external factors and operating type. Fuses normally protect the system only, not the motor.

Tolerances (IEC 60 034-1)

Efficiency	
Motors up to 150 kW : P<150 kW	- 0,15 (1 - η)
Motors bigger than 150 kW : P>150 kW	- 0,10 (1 - η)W
Power coefficient cos φ	
	$\frac{1 - \cos \varphi}{6}$ min. 0,02 max. 0,07
Slipping (at full load and operating temperature)	
	For PN < 1 kW motors, ± %30 is allowed. For PN > 1 kW motors, ± %20 is allowed.
Start-up current	
	± 20%
Start-up torque	
	- From %15 to + %25 (With special agreement, +%25 can be exceeded)
Overturning Torque	
	- 10% (Even after this tolerance ratio is applied, the maximum torque should not be less than 1.6 times the nominal torque.)
Torque of Inertia	
	± 10%
Noise limit	
	+ 3dB (A)

The below table shows the efficiency categories specified in the IEC 60034-30-1: 2014 standard.

IE4 Süper Premium IE3 Premium (very high) Efficiency IE2 High Efficiency IE1 Standard Efficiency	IEC 60034-30-1:2014	0,12-1000 kW 2,4,6 and 8 pole motors
---	---------------------	---

According to the communiqué entering into force in Turkey on April 2, 2012, the power range should be 0.75... 375kW, and the number of poles covered should be 2, 4 and 6 poles in the motors.

According to the relevant communiqué, as of 2017, all 2, 4 and 6-pole motors with a power range of 0.75... 375 kW must be in IE3 efficiency class. The use of IE2 motors is only permitted in speed control applications.

According to the communiqué updated on March 13, 2015, the efficiency class will also be applied in the following cases;

- At an altitude of 4000 m above sea level and an ambient temperature of up to 60 °C (the previous communiqué covered up to 1000m and 40 °C)
- If the efficiency test of motors that are fully integrated into a product such as reducer, pump, fan and compressor can be done independently of the product, they are covered by the new communiqué. (For example, efficiency classes are also applied to motors that are coupled to the reducer with a special shaft and/or cover.)

According to the IEC 60034-2-1: 2014 standard, the methods to be used to determine the losses and efficiency in electric motors are specified. The measurement methods specified in the standard, in which more precise measurement and calculation methods are used for the calculation of additional losses, are as follows:

Test Standard IEC 60 034-2-1:2014

- Direct measurement method
- Indirect measurement method
 - Additional losses (P_{LL}) are determined based on test results at different load values.
 - Additional losses (P_{LL}) are taken into account at rates varying between 2.5% and 1% of the input power in motors from 0.1 kW to 1000 kW.
 - Additional losses (P_{LL}) are based on mathematical calculations.

The results of the tests performed to assess the efficiency classes of the motors are determined according to the test results obtained at different load values of the additional losses in the indirect measurement method.

The efficiency values on the Operational Characteristics pages are calculated by the indirect measurement method in accordance with the IEC 60034-2-1: 2014 standard. Additional losses are assessed based on test results performed at variable load values. This is considered the most accurate method.

STANDARD
SERIES

”
THREE PHASE
MOTORS
“

OPERATIONAL CHARACTERISTICS

3 Phase, 400 V, 50 Hz | Type of Operation: S1 (Continuous Operation)

Protection Degree: IP 55 | Insulation Class: H (180°C) | Heat Increase Limit: B (80K)

Standard Series
Three Phase Motors

IE2

ALUMINUM FRAME

2 poles - 3000 RPM

Nominal Power	Type	At Nominal Power							At Start-up				Tilting Moment Ratio	Moment of Inertia	Approx. Weight
		Speed	Current	Torque	Power Coefficient Cos φ	Efficiency η			Current Ratio		Torque Ratio				
		RPM	A	Nm		4/4	3/4	1/2	Direct	Y/Δ	Direct	Y/Δ			
0,75	AGM2E 80 M 2a	2860	1,7	2,5	0,82	77,4	77,4	74,6	6,2	-	2,5	-	3	0,00053	8
1,1	AGM2E 80 M 2b	2880	2,3	3,6	0,87	79,6	79,6	77,9	6,3	-	2,7	-	3	0,00066	8,8
1,5	AGM2E 90 S 2a	2880	3,3	5	0,81	81,3	81,3	79,8	6,3	-	2,3	-	3	0,0011	11,5
2,2	AGM2E 90 L 2b	2870	4,5	7,3	0,85	83,2	83,2	81,9	6,6	-	2,6	-	3,1	0,0014	13,9
3	AGM2E 100 L 2a	2880	5,9	9,9	0,89	84,6	84,6	84,1	6	-	2,5	-	3	0,0025	20
4	AGM2E 112 M 2a	2880	7,9	13,3	0,85	85,8	85,8	85	7,2	2,4	2,8	0,9	3,5	0,0039	21,5
5,5	AGM2E 132 S 2a	2900	10,3	18,1	0,89	87	87	86,5	6,6	2,2	2,5	0,8	3,1	0,0108	37
7,5	AGM2E 132 S 2b	2910	13,6	24,6	0,90	88,1	88,1	87,9	7,2	2,4	3	1	3,4	0,014	44
11	AGM2E 160 M 2a	2945	19,5	35,7	0,91	89,4	89,4	88,6	7,7	2,6	3,4	1,1	3,6	0,030	67
15	AGM2E 160 M 2b	2945	28,3	48,6	0,85	90,3	90,3	89,7	7,5	2,5	3	1	3,5	0,041	81
18,5	AGM2E 160 H 2c	2950	32,3	59,9	0,91	90,9	90,8	90,1	7,7	2,6	2,5	0,8	3	0,048	102
22	AGM2E 180 M 2a	2950	38,3	71,2	0,91	91,3	91,3	90,8	8,2	2,7	3	1	3,5	0,066	135
30	AGM2E 200 L 2a	2970	52	96,5	0,91	92	92	91,2	8,3	2,8	2,7	0,9	3	0,13	160
37	AGM2E 200 L 2b	2970	65	119	0,89	92,5	92,5	91,7	8,3	2,8	2,7	0,9	3	0,15	190

Efficiency values are calculated by the indirect measurement method in accordance with IEC 60034-2-1: 2014 standard. Additional losses are assessed based on test results performed at variable load values.

Standard Series
Three Phase Motors

IE2

OPERATIONAL CHARACTERISTICS

3 Phase, 400 V, 50 Hz | Type of Operation: S1 (Continuous Operation)

Protection Degree: IP 55 | Insulation Class: F (155°C) | Heat Increase Limit: B (80K)

CAST IRON FRAME

2 poles - 3000 RPM

Nominal Power	Type	At Nominal Power							At Start-up				Tilting Moment Ratio	Moment of Inertia	Approx. Weight
		Speed	Current	Torque	Power Coefficient Cos φ	Efficiency η			Current Ratio		Torque Ratio				
		RPM	A	Nm		4/4	3/4	1/2	Direct	Y/Δ	Direct	Y/Δ			
5,5	GM2E 132 S 2a	2900	10,3	18,1	0,89	87	87	86,5	7,3	2,4	2,8	0,9	3,5	0,0108	49
7,5	GM2E 132 S 2b	2910	13,6	24,6	0,90	88,1	88,1	87,9	7,2	2,4	3	1	3,4	0,014	56
11	GM2E 160 M 2a	2945	19,5	35,7	0,91	89,4	89,4	88,6	7,7	2,6	3,4	1,1	3,6	0,03	100
15	GM2E 160 M 2b	2945	28,3	48,6	0,85	90,3	90,3	89,7	7,5	2,5	3	1	3,5	0,041	113
18,5	GM2E 160 L 2c	2950	32,3	59,9	0,91	90,9	90,8	90,1	7,7	2,6	2,5	0,8	3	0,048	135
22	GM2E 180 M 2a	2950	38,3	71,2	0,91	91,3	91,3	90,8	8,2	2,7	3	1	3,5	0,066	158
30	GM2E 200 L 2a	2970	52	96,5	0,91	92	92	91,2	8,3	2,8	2,7	0,9	3	0,13	210
37	GM2E 200 L 2b	2970	65	119	0,89	92,5	92,5	91,7	8,3	2,8	2,7	0,9	3	0,15	240
55	GM2E 250 M 2a	2980	94	176,3	0,91	93,2	93,7	92,2	7,6	2,5	2,6	0,9	2,7	0,41	445
75	GM2E 280 S 2a	2980	128	240,4	0,91	93,8	94	92,5	7	2,3	2,4	0,8	2,5	0,53	512
90	GM2E 280 M 2b	2980	152	288,4	0,91	94,1	94,1	92,7	8,5	2,8	2,7	0,9	3	0,62	585
110	GM2E 315 S 2a	2980	192	352,5	0,88	94,3	94,3	92,8	7	2,3	2,5	0,8	3	1	675
132	GM2E 315 M 2b	2980	224	423	0,90	94,6	94,5	92,9	8	2,7	2,5	0,8	3	1,2	742
160	GM2E 315 M 2c	2980	266	512,8	0,92	94,8	94,8	93,4	7,8	2,6	2,5	0,8	3	1,4	812
185	GMM2E 315 L 2d	2980	307	592,9	0,92	95	95	93,6	8	2,7	2,5	0,8	3	1,5	912
200	GMM2E 315 L 2e	2980	330	640,9	0,92	95	95	93,6	8	2,7	2,5	0,8	3	1,5	912
250	GMM2E 315 L 2f	2970	415	803,6	0,92	95	95	93,6	7,5	2,5	2,5	0,8	2,9	1,94	932
250	GMM2E 355 M 2a	2980	420	801,2	0,90	95	95	93,6	8	2,7	2	0,7	2,3	3,3	1170
315	GMM2E 355 M 2b	2980	530	1009,5	0,90	95	95	93,7	8	2,7	2	0,7	2,3	4,1	1300
355	GMM2E 355 M 2c	2980	600	1137,7	0,90	95	95	93,8	8	2,7	2	0,7	2,3	4,5	1360
400	GMM2E 355 L 2d	2980	670	1281,9	0,91	95	95	93,8	8	2,7	2	0,7	2,3	4,7	1520

*Nominal current at 690 V.

Efficiency values are calculated by the indirect measurement method in accordance with IEC 60034-2-1: 2014 standard. Additional losses are assessed based on test results performed at variable load values.

OPERATIONAL CHARACTERISTICS

3 Phase, 400 V, 50 Hz | Type of Operation: S1 (Continuous Operation)

Protection Degree: IP 55 | Insulation Class: H (180°C) | Heat Increase Limit: B (80K)

Standard Series
Three Phase Motors

IE2

ALUMINUM FRAME

4 poles - 1500 RPM

Nominal Power	Type	At Nominal Power							At Start-up				Tilting Moment Ratio	Moment of Inertia	Approx. Weight
		Speed	Current	Torque	Power Coefficient Cos φ	Efficiency η			Current Ratio		Torque Ratio				
		RPM	A	Nm		4/4	3/4	1/2	Direct	Y/Δ	Direct	Y/Δ			
0,75	AGM2E 80 M 4b	1410	2	5,1	0,68	79,6	79,6	77,6	5	-	2,6	-	2,8	0,0014	10,4
1,1	AGM2E 90 S 4a	1420	2,6	7,4	0,75	81,4	81,4	80,5	5,5	-	3	-	3,3	0,0022	12,5
1,5	AGM2E 90 L 4b	1430	3,5	10	0,75	82,8	82,8	81,5	5,9	-	3,3	-	3,5	0,003	15,5
2,2	AGM2E 100 L 4a	1435	5	14,6	0,76	84,3	84,3	82,5	5,9	-	2,9	-	3,4	0,0044	17,5
3	AGM2E 100 H 4b	1435	6,6	20	0,77	85,5	85,7	84	6,2	-	2,9	-	3,4	0,0057	24
4	AGM2E 112 M 4a	1455	8,4	26,3	0,81	86,6	86,7	85,3	6,6	2,2	2,5	0,8	3,3	0,0106	30
5,5	AGM2E 132 S 4a	1465	11,2	35,9	0,81	87,7	87,7	87,2	7	2,3	2,8	0,9	3,5	0,026	41
7,5	AGM2E 132 M 4b	1465	15,4	48,9	0,79	88,7	88,8	88,1	7,1	2,4	2,7	0,9	3,4	0,026	48
11	AGM2E 160 M 4a	1465	21,3	71,7	0,83	89,8	89,9	89,3	6,9	2,3	2,8	0,9	3,1	0,067	85
15	AGM2E 160 H 4b	1465	29,8	97,8	0,8	90,6	90,7	89,7	7,5	2,5	2,6	0,9	3,5	0,088	105
18,5	AGM2E 180 M 4a	1470	34,5	120,2	0,85	91,2	91,4	90,4	7,7	2,6	3,2	1,1	3,4	0,13	145
22	AGM2E 180 L 4b	1470	42,5	142,9	0,82	91,6	91,4	90,6	8,3	2,8	2,7	0,9	3,8	0,15	160
30	AGM2E 200 L 4a	1470	55	194,9	0,85	92,3	92,4	92,1	8	2,7	3,1	1	3,6	0,22	175

Efficiency values are calculated by the indirect measurement method in accordance with IEC 60034-2-1: 2014 standard. Additional losses are assessed based on test results performed at variable load values.

Standard Series
Three Phase Motors

IE2

OPERATIONAL CHARACTERISTICS

3 Phase, 400 V, 50 Hz | Type of Operation: S1 (Continuous Operation)

Protection Degree: IP 55 | Insulation Class: F (155°C) | Heat Increase Limit: B (80K)

PİK GÖVDE

4 poles - 1500 RPM

Nominal Power	Type	At Nominal Power							At Start-up				Tilting Moment Ratio	Moment of Inertia	Approx. Weight
		Speed	Current	Torque	Power Coefficient Cos φ	Efficiency η			Current Ratio		Torque Ratio				
		RPM	A	Nm		4/4	3/4	1/2	Direct	Y/Δ	Direct	Y/Δ			
5,5	GM2E 132 S 4a	1465	11,2	35,9	0,81	87,7	87,7	87,2	7	2,3	2,8	0,9	3,5	0,021	53
7,5	GM2E 132 M 4b	1465	15,4	48,9	0,79	88,7	88,8	88,1	7,1	2,4	2,7	0,9	3,4	0,026	61
11	GM2E 160 M 4a	1465	21,3	71,7	0,83	89,8	89,9	89,3	6,9	2,3	2,8	0,9	3,1	0,067	115
15	GM2E 160 L 4b	1465	29,8	97,8	0,8	90,6	90,7	89,7	7,5	2,5	2,6	0,9	3,5	0,088	135
18,5	GM2E 180 M 4a	1470	34,5	120,2	0,85	91,2	91,4	90,4	7,7	2,6	3,2	1,1	3,4	0,13	165
22	GM2E 180 L 4b	1470	42,5	142,9	0,82	91,6	91,4	90,6	8,3	2,8	2,7	0,9	3,8	0,15	180
30	GM2E 200 L 4a	1470	55,0	194,9	0,85	92,3	92,4	92,1	8	2,7	3,1	1	3,6	0,22	225
55	GM2E 250 M 4a	1475	96,8	356,1	0,88	93,5	93,6	93,2	7,6	2,5	3,1	1	2,9	0,72	420
75	C.GM2E 250 M 4b	1475	132	485,6	0,87	94	94	93,2	7,5	2,5	3,1	1,1	2,7	1	490
75	GM2E 280 S 4a	1480	133	484	0,87	94	94,1	93,4	7	2,3	2,6	0,9	2,8	0,96	550
90	GM2E 280 M 4b	1480	158	580,7	0,87	94,2	94,5	93,8	7,4	2,5	2,9	1	3	1,15	615
110	C.GM2E 280 M 4c	1485	195	707,4	0,86	94,5	94,5	93,8	7,4	2,5	2,9	1	3	2,1	750
110	GM2E 315 S 4a	1485	195	707,4	0,86	94,5	94,5	93,8	7,4	2,5	2	0,7	3	2,1	784
132	GM2E 315 M 4b	1485	230	848,9	0,87	94,7	94,5	93,8	7,4	2,5	2,1	0,7	3	2,5	861
160	GM2E 315 M 4c	1485	280	1029	0,87	94,9	94,9	94	7	2,3	2	0,7	2,9	2,8	882
185	GMM2E 315 L 4d	1485	323	1189,7	0,87	95,1	95,1	94,2	7,4	2,5	2,2	0,7	3	2,9	962
200	GMM2E 315 L 4e	1485	350	1286,2	0,87	95,1	95,4	94,2	8	2,7	2,5	0,8	3	3,1	1015
250	GM2E 315 H 4f	1485	425	1607,1	0,89	95,1	95,1	94,2	8,1	2,7	2,3	0,8	3	3,5	1200
250	GMM2E 355 M 4a	1485	445	1607,7	0,85	95,1	95,1	94,2	6,4	2,1	2,1	0,7	2,8	5,5	1378
315	GMM2E 355 M 4b	1490	560	2019	0,85	95,1	95,1	94,5	6,4	2,1	2	0,7	2,8	6	1400
355	GMM2E 355 M 4c	1490	630	2275,3	0,86	95,1	95,4	94,2	7	2,3	2	0,7	2,8	6,5	1438
400	GMM2E 355 L 4d	1490	710	2563,8	0,86	95,1	95,1	94,5	7	2,3	2	0,7	2,8	7,2	1639

*Nominal current at 690 V.

Efficiency values are calculated by the indirect measurement method in accordance with IEC 60034-2-1: 2014 standard. Additional losses are assessed based on test results performed at variable load values.

HIGH EFFICIENCY MOTORS

OPERATIONAL CHARACTERISTICS

3 Phase, 400 V, 50 Hz | Type of Operation: S1 (Continuous Operation)
Protection Degree: IP 55 | Insulation Class: H (180°C) | Heat Increase Limit: B (80K)

Standard Series
Three Phase Motors

IE2

ALUMINUM FRAME

6 poles - 1000 RPM

Nominal Power kW	Type	At Nominal Power							At Start-up				Tilting Moment Ratio	Moment of Inertia	Approx. Weight
		Speed RPM	Current A	Torque Nm	Power Coefficient Cos φ	Efficiency η			Current Ratio		Torque Ratio				
						4/4	3/4	1/2	Direct	Y/Δ	Direct	Y/Δ			
0,75	AGM2E 90 S 6a	920	2	7,8	0,71	75,9	75,9	72,4	4	-	2,2	-	2,4	0,0034	12,2
1,1	AGM2E 90 L 6b	930	2,9	11,3	0,7	78,1	78,1	75,1	4	-	2,2	-	2,4	0,0044	14
1,5	AGM2E 100 L 6a	945	3,6	15,2	0,76	79,8	79,7	76,4	4,5	-	2,2	-	2,4	0,0077	19,1
2,2	AGM2E 112 M 6a	950	5,4	22,1	0,72	81,8	81,7	78,5	4,7	-	2,2	-	2,5	0,013	26,5
3	AGM2E 132 S 6a	960	6,9	29,8	0,75	83,3	83,2	80,4	5	1,7	2,2	0,7	2,6	0,028	44
4	AGM2E 132 M 6b	960	9	39,8	0,76	84,6	84,5	81,6	5	1,7	2,2	0,7	2,6	0,037	49
5,5	AGM2E 132 H 6c	960	12,3	54,7	0,75	86	86	83,1	5	1,7	2,2	0,7	2,6	0,06	62
7,5	AGM2E 160 M 6a	960	15	74,6	0,83	87,2	87,2	84,5	6,5	2,2	2,5	0,8	3	0,08	75
11	AGM2E 160 L 6b	965	22	108,9	0,81	88,7	88,7	85,7	6,5	2,2	2,5	0,8	3	0,12	102
15	AGM2E 180 L 6a	965	29	148,4	0,83	89,7	89,7	86,8	6,5	2,2	2,4	0,8	3	0,2	165
18,5	AGM2E 200 L 6a	975	38	181,2	0,78	90,4	90,4	97,7	7	2,3	2,5	0,8	3	0,21	168
22	AGM2E 200 L 6b	970	43	216,6	0,81	90,9	90,9	88,4	7	2,3	2,5	0,8	3	0,26	185

CAST IRON FRAME

6 poles - 1000 RPM

3	GM2E 132 S 6a	960	6,9	29,8	0,75	83,3	83,2	80,4	5	1,7	2,2	0,7	2,6	0,028	56
4	GM2E 132 M 6b	960	9	39,8	0,76	84,6	84,5	81,6	5	1,7	2,2	0,7	2,6	0,037	62
7,5	GM2E 160 M 6a	960	15	74,6	0,83	87,2	87,2	84,5	6,5	2,2	2,5	0,8	3	0,08	105
11	GM2E 160 L 6b	965	22	108,9	0,81	88,7	88,7	85,7	6,5	2,2	2,5	0,8	3	0,12	132
15	GM2E 180 L 6a	965	29	148,4	0,83	89,7	89,7	86,8	6,5	2,2	2,4	0,8	3	0,2	189
18,5	GM2E 200 L 6a	975	38	181,2	0,78	90,4	90,4	97,7	7	2,3	2,5	0,8	3	0,21	202
22	GM2E 200 L 6b	970	43	216,6	0,81	90,9	90,9	88,4	7	2,3	2,5	0,8	3	0,26	222
37	GM2E 250 M 6a	985	71,4	358,7	0,81	92,2	92,2	90,1	7	2,3	3	1	2,6	0,77	380
45	GM2E 280 S 6a	985	92	436,3	0,76	92,7	92,7	90,9	7	2,3	3,3	1,1	2,6	1,2	500
55	GM2E 280 M 6b	985	107	533,2	0,80	93,1	93,1	91,5	7	2,3	3,3	1,1	2,6	1,5	553
75	C.GM2E 280 M 6c	990	144	723,4	0,80	93,7	93,7	93,2	6,9	2,3	3,8	1,3	3	2	568
75	GM2E 315 S 6a	990	139	723,5	0,83	93,7	93,7	92,4	7	2,3	2	0,7	3	2,4	727
90	GM2E 315 M 6b	990	166	868,2	0,83	94	94	92,6	7	2,3	2	0,7	3	2,9	805
110	GM2E 315 M 6c	990	198	1061,1	0,85	94,3	94,3	92,7	7	2,3	2	0,7	3	3,5	860
132	GMM2E 315 L 6d	990	237	1273,3	0,85	94,6	94,6	93	7	2,3	2,3	0,8	3	3,6	1020
160	GMM2E 315 L 6e	990	290	1543,4	0,84	94,8	94,8	93,2	7	2,3	2,3	0,8	3	4,2	1120
160	GMM2E 355 M 6a	990	305	1543,4	0,80	94,8	94,8	93,2	7	2,3	2,5	0,8	2,4	6,8	1035
200	GMM2E 355 M 6b	990	380	1929,3	0,80	95	95	93,5	7	2,3	2,5	0,8	2,4	6,8	1185
250	GMM2E 355 M 6c	990	470	2411,6	0,81	95	95	93,5	7	2,3	2,5	0,8	2,4	8,3	1390
315	GMM2E 355 L 6d	990	580	3038,6	0,83	95	95	93,5	7	2,3	2,5	0,8	2,4	10,7	1746
355	GMM2E 355 L 6e	990	650	3424,5	0,83	95	95	93,5	7	2,3	2,5	0,8	2,4	11,7	1890
355	GMM2E 400 L 6a	995	655	3407,3	0,82	95	95	93,5	7	2,3	2	0,7	2,6	19,6	2250
400	GMM2E 400 L 6b	995	740	3839,2	0,82	95	95	93,5	7	2,3	2	0,7	2,6	24,5	2575

*Nominal current at 690 V.
Efficiency values are calculated by the indirect measurement method in accordance with IEC 60034-2-1: 2014 standard. Additional losses are assessed based on test results performed at variable load values.

Standard Series
Three Phase Motors

IE-

STANDARD SERIES MOTORS

OPERATIONAL CHARACTERISTICS

3 Phase, 400 V, 50 Hz | Type of Operation: S1 (Continuous Operation)
Protection Degree: IP 55 | Insulation Class: F (155°C) | Heat Increase Limit: B (80K)

ALUMINUM FRAME

2 poles (3000 RPM)

Nominal Power kW	Type	At Nominal Power							At Start-up				Tilting Moment Ratio	Moment of Inertia	Approx. Weight
		Speed RPM	Current A	Torque Nm	Power Coefficient Cos φ	Efficiency η			Current Ratio		Torque Ratio				
						4/4	3/4	1/2	Direct	Y/Δ	Direct	Y/Δ			
0,09	AGM 56 M 2a	2800	0,25	0,3	0,82	63,4	63,1	55,8	4,1	-	2,7	-	2,8	0,00011	2,7
0,12	AGM 56 M 2b	2800	0,35	0,4	0,77	64,5	64,1	56,9	4,2	-	2,5	-	2,8	0,00012	2,8
0,18	AGM 63 M 2a	2820	0,55	0,6	0,81	64,4	64,2	57,7	4,6	-	2,9	-	2,9	0,00011	3,6
0,25	AGM 63 M 2b	2840	0,65	0,8	0,8	67,3	67,1	60,9	4,5	-	2,5	-	2,9	0,00013	4
0,37	C.AGM 63 M 2c	2850	1,1	1,2	0,75	68,1	68,1	61,3	5	-	2,5	-	2,7	0,00018	4,7
0,37	AGM 71 M 2a	2800	1,05	1,3	0,74	68,9	68,7	66,7	5	-	2,4	-	2,6	0,00026	4,9
0,55	AGM 71 M 2b	2780	1,3	1,9	0,85	72	71,8	70,3	4,5	-	2,4	-	2,6	0,00034	6

450	GMM 355 L 2e	2980	750	1442,1	0,91	95	95	93,8	7	2,3	2	0,7	2,6	5,3	1630
500	GMM 355 L 2f	2980	830	1602,3	0,92	95	95	93,8	7	2,3	2	0,7	2,6	5,9	1740
450	GMM 400 L 2a	2985	741	1439,7	0,92	95	95	93,9	7	2,3	1,5	0,5	2,2	7,1	2210
500	GMM 400 L 2b	2985	822	1599,7	0,92	95	95	93,9	7	2,3	1,5	0,5	2,2	7,9	2450
560	GMM 400 L 2c	2985	907	1791,6	0,93	95	95	94,3	7	2,3	1,5	0,5	2,2	8,8	2600
630	GMM 400 L 2d	2985	1017	2015,6	0,93	95	95	94,3	7	2,3	1,5	0,5	2,2	9,9	2820
710	GMM 400 L 2e	2985	675	2271,5	0,92	95	95	94,4	7	2,3	1,5	0,5	2,2	11,2	3000
800	GMM 450 L 2a	2986	760	2558,6	0,92	95	95	94,4	7	2,3	1	0,3	2,8	21	3600
900	GMM 450 H 2b	2986	842	2878,4	0,93	95	95	94,5	7	2,3	1	0,3	2,8	23	3800
1000	GMM 450 H 2c	2986	923	3198,3	0,94	95	95	94,5	7	2,3	1	0,3	2,8	26	4000

STANDARD SERIES MOTORS

OPERATIONAL CHARACTERISTICS

3 Phase, 400 V, 50 Hz | Type of Operation: S1 (Continuous Operation)

Protection Degree: IP 55 | Insulation Class: H (180°C) | Heat Increase Limit: B (80K)

Standard Series
Three Phase Motors

IE-

ALUMINUM FRAME

4 poles (1500 RPM)

Nominal Power kW	Type	At Nominal Power							At Start-up				Tilting Moment Ratio	Moment of Inertia	Approx. Weight
		Speed	Current	Torque	Power Coefficient Cos φ	Efficiency η			Current Ratio		Torque Ratio				
		RPM	A	Nm		4/4	3/4	1/2	Direct	Y/Δ	Direct	Y/Δ			
0,06	AGM 56 M 4a	1370	0,26	0,4	0,61	56,9	56,8	52,2	3	-	2,4	-	2,6	0,00011	2,6
0,09	AGM 56 M 4b	1375	0,4	0,6	0,58	62,5	62,3	55,1	3,1	-	2,2	-	2,4	0,00012	2,8
0,12	AGM 63 M 4a	1365	0,45	0,8	0,74	57,1	57,1	53,3	3,1	-	2	-	2,2	0,00017	3,4
0,18	AGM 63 M 4b	1340	0,6	1,3	0,73	59,7	59,7	55,8	2,9	-	2	-	2	0,00021	3,9
0,25	C.AGM 63 M 4c	1350	0,95	1,8	0,63	60,7	60,7	56,8	3	-	2	-	2	0,00026	4,5
0,25	AGM 71 M 4a	1380	0,8	1,7	0,72	61,9	61,8	58,2	2,9	-	1,8	-	2,2	0,0004	4,9
0,37	AGM 71 M 4b	1390	1,15	2,5	0,68	68,1	68,1	67,1	3,7	-	2,2	-	2,5	0,00054	5,8
0,55	C.AGM 71 M 4c	1385	1,6	3,8	0,75	68,6	68,6	67,6	3,4	-	1,9	-	2,1	0,00062	6,4
0,55	AGM 80 M 4a	1365	1,6	3,8	0,72	69,1	69	65,2	3,5	-	1,9	-	2	0,00083	7,5

CAST IRON FRAME

4 poles (1500 RPM)

450	GMM 355 L 4e	1490	800	2884,2	0,85	95,4	95,4	94,5	7	2,3	2,5	0,8	2,6	8,2	1740
500	GMM 355 L 4f	1490	890	3204,7	0,85	95,1	95,1	94,5	7	2,3	2,4	0,8	2,6	9,1	1850
450	GMM 400 L 4a	1490	770	2884,2	0,88	95,6	95,6	94,8	7	2,3	1,9	0,6	2,6	14,7	2335
500	GMM 400 L 4b	1490	860	3204,7	0,88	95,6	95,6	94,8	7	2,3	1,9	0,6	2,6	16,9	2474
560	GMM 400 L 4c	1490	970	3589,3	0,87	95,6	95,6	95,1	7	2,3	1,9	0,6	2,6	20	2745
630	GMM 400 L 4d	1490	1090	4037,9	0,87	95,6	95,6	95,1	7,2	2,4	2	0,7	2,8	21,3	2814
710	GMM 400 L 4e	1490	710	4550,7	0,87	96	96	95,2	7,2	2,4	2	0,7	3	23,8	3055
800	GMM 450 L 4a	1490	784	5127,5	0,89	95,1	95,1	95,3	7	2,3	1,8	0,6	2,5	28	3700
900	GMM 450 H 4b	1490	880	5768,5	0,89	95,1	95,1	95,3	7	2,3	1,8	0,6	2,5	32	3900
1000	GMM 450 H 4c	1490	976	6409,4	0,89	95,1	95,1	95,3	7	2,3	1,8	0,6	2,5	35	4100

*Nominal current at 690 V.

Efficiency values are calculated by the indirect measurement method in accordance with IEC 60034-2-1: 2014 standard. Additional losses are assessed based on test results performed at variable load values.

Standard Series
Three Phase Motors

IE-

STANDARD SERIES MOTORS

OPERATIONAL CHARACTERISTICS

3 Phase, 400 V, 50 Hz | Type of Operation: S1 (Continuous Operation)

Protection Degree: IP 55 | Insulation Class: F (155°C) | Heat Increase Limit: B (80K)

ALUMINUM FRAME

6 poles (1000 RPM)

Nominal Power kW	Type	At Nominal Power							At Start-up				Tilting Moment Ratio	Moment of Inertia	Approx. Weight
		Speed	Current	Torque	Power Coefficient Cos φ	Efficiency η			Current Ratio		Torque Ratio				
		RPM	A	Nm		4/4	3/4	1/2	Direct	Y/Δ	Direct	Y/Δ			
0,18	AGM 71 M 6a	915	0,6	1,9	0,68	63	62,9	58,7	3,2	-	1,7	-	2,1	0,00064	5
0,25	AGM 71 M 6b	915	0,87	2,6	0,68	63,8	63,7	59,6	3,2	-	1,7	-	2,1	0,00086	5,7
0,37	AGM 80 M 6a	910	1,1	3,9	0,67	72,9	72,8	70,1	3,6	-	2,1	-	2,4	0,0017	8,1
0,55	AGM 80 M 6b	890	1,5	5,9	0,75	70,4	70,3	68,2	3,5	-	1,9	-	2	0,0022	9,4

CAST IRON FRAME

6 poles (1000 RPM)

450	GMM 400 L 6c	995	840	4319,1	0,81	95,4	95,4	93,9	6,5	2,2	1,8	0,6	2,6	26,6	2705
500	GMM 400 L 6d	995	920	4799	0,82	95,4	95,4	93,9	7	2,3	1,8	0,6	2,6	29,2	2855
560	GMM 400 L 6e	995	1010	5374,9	0,84	95	95	93,5	7	2,3	1,8	0,6	2,6	32,2	3030
630	GMM 450 L 6a	995	685	6046,7	0,81	95,7	95,7	94,1	6,6	2,2	1,9	0,6	2,5	37	3800
710	GMM 450 L 6b	995	713	6814,6	0,87	95	95	93,5	6,6	2,2	1,9	0,6	2,5	41	4000
800	GMM 450 H 6c	995	794	7678,4	0,88	95	95	93,5	6,6	2,2	1,9	0,6	2,5	46	4200

*Nominal current at 690 V.

Efficiency values are calculated by the indirect measurement method in accordance with IEC 60034-2-1: 2014 standard. Additional losses are assessed based on test results performed at variable load values.

STANDARD SERIES MOTORS

Standard Series
Three Phase Motors

OPERATIONAL CHARACTERISTICS

3 Phase, 400 V, 50 Hz | Type of Operation: S1 (Continuous Operation)
Protection Degree: IP 55 | Insulation Class: H (180°C) | Heat Increase Limit: B (80K)

IE-

ALUMINUM FRAME

8 poles - 750 RPM

Nominal Power kW	Type	At Nominal Power							At Start-up				Tilting Moment Ratio	Moment of Inertia	Approx. Weight
		Speed	Current	Torque	Power Coefficient Cos φ	Efficiency η			Current Ratio		Torque Ratio				
		RPM	A	Nm		4/4	3/4	1/2	Direct	Y/Δ	Direct	Y/Δ			
0,09	AGM 71 M 8a	690	0,4	1,2	0,56	56,5	56,5	47,4	2,3	-	1,7	-	1,9	0,00064	5
0,12	AGM 71 M 8b	670	0,6	1,7	0,51	56,7	56,7	47,7	2,2	-	1,9	-	2	0,00086	5,7
0,18	AGM 80 M 8a	695	0,9	2,5	0,48	60,3	60,3	54,7	3	-	2,8	-	3	0,0017	8,1
0,25	AGM 80 M 8b	680	1,1	3,5	0,5	630	63	57,6	2,9	-	2,6	-	2,8	0,0022	9,4
0,37	AGM 90 S 8a	690	1,3	5,1	0,6	66,7	66,7	61,5	3,2	-	1,8	-	2	0,0029	11,3
0,55	AGM 90 L 8b	670	1,8	7,8	0,63	69,6	69,6	64,6	3	-	1,4	-	1,7	0,0038	13,3
0,75	AGM 100 L 8a	700	2,5	10,2	0,74	61,2	61,2	61,2	3,4	-	1,8	-	2,1	0,0062	17,4
1,1	AGM 100 L 8b	700	3,3	15	0,73	66,5	66,5	66,4	3,2	-	1,7	-	1,8	0,0084	19,1
1,5	AGM 112 M 8a	700	4,4	20,5	0,7	70,2	71	71	3,6	-	1,9	-	2,2	0,013	21,5
2,2	AGM 132 S 8a	700	5,4	30	0,76	77,2	77,1	73,1	3,8	1,3	2,1	0,7	2,4	0,024	32
3	AGM 132 M 8b	690	7,3	41,5	0,76	78,1	78	74,2	3,6	1,2	2,2	0,7	2,2	0,033	40
4	AGM 160 M 8a	710	9,1	53,8	0,77	82,2	82,2	79,3	4,8	1,6	2,1	0,7	2,4	0,06	63
5,5	AGM 160 M 8b	720	12,5	73	0,78	81,4	81,4	79,6	5,3	1,8	2,2	0,7	2,7	0,083	73
7,5	AGM 160 L 8c	715	17	100,2	0,77	83,1	83,1	83	5,8	1,9	2,4	0,8	2,9	0,12	120
11	AGM 180 L 8a	720	24	145,9	0,78	85,2	85,2	82,1	6,8	2,3	2,7	0,9	3	0,2	138
15	AGM 200 L 8a	725	32	197,6	0,78	86,2	85,2	84,2	6	2	2,1	0,7	2,9	0,29	155

CAST IRON FRAME

8 poles - 750 RPM

2,2	GM 132 S 8a	700	5,4	30	0,76	77,2	77,1	73,1	3,8	1,3	2,1	0,7	2,4	0,024	47
3	GM 132 M 8b	690	7,3	41,5	0,76	78,1	78	74,2	3,6	1,2	2,2	0,7	2,2	0,033	56
4	GM 160 M 8a	710	9,2	53,8	0,79	80	80	79	4,8	1,6	2,1	0,7	2,4	0,06	84
5,5	GM 160 M 8b	720	12,6	73	0,78	81,4	81,4	79,6	5,3	1,8	2,2	0,7	2,7	0,083	98
7,5	GM 160 L 8c	715	18	100,2	0,76	83,1	83,1	83	5,8	1,9	2,4	0,8	2,9	0,12	120
11	GM 180 L 8a	720	23,8	145,9	0,78	85	85,2	82,1	6,8	2,3	2,7	0,9	2	0,2	164
15	GM 200 L 8a	725	32	197,6	0,78	86,2	85,2	84,2	6	2	2,1	0,7	2,9	0,29	205
30	GM 250 M 8a	735	59	389,8	0,82	89,8	89,8	86,2	6,1	2	1,8	0,6	2,6	0,92	383
37	GM 280 S 8a	730	73	484	0,82	88,8	88,8	85,2	4,7	1,6	2	0,7	2	1,3	465
45	GM 280 M 8b	730	86	588,7	0,83	91,4	91,4	87,4	4,9	1,6	1,9	0,6	1,8	1,6	508
55	GM 315 S 8a	740	110	709,8	0,77	93,7	92,2	87,4	5,7	1,9	1,8	0,6	2	2	708
75	GM 315 M 8b	740	153	967,9	0,76	92,7	91,3	87,4	5,9	2	1,9	0,6	2	2,5	745
90	GM 315 M 8c	740	180	1161,5	0,77	93,6	92,2	88,6	6,2	2,1	1,9	0,6	2	3	820
110	GMM 315 L 8d	740	209	1419,6	0,82	92,6	92,6	89,1	6,5	2,2	1,9	0,6	2	4	860
132	GMM 315 L 8e	740	262	1703,5	0,78	93,1	93,1	89,8	6	2	1,9	0,6	2	4,3	980
132	GMM 355 M 8a	740	290	1703,5	0,73	94,4	94,4	89,8	5,7	1,9	1,9	0,6	2	4,3	1222
160	GMM 355 M 8b	740	320	2064,9	0,76	94,6	94,4	90,2	5,9	2	1,9	0,6	2	8,9	1328
200	GMM 355 M 8c	740	420	2581,1	0,73	94,4	94,4	90,3	6,2	2,1	1,9	0,6	2	11	1590
250	GMM 355 L 8d	740	475	3226,4	0,7	93,5	94	94	6,5	2,2	1,9	0,6	2	13	2020
315	GMM 400 L 8a	745	650	4037,9	0,76	92,5	93	93	5,9	2	1,8	0,6	2,3	24,5	2555
355	GMM 400 L 8b	745	735	4550,7	0,73	93,5	94	94	6	2	1,8	0,6	2,3	26,6	2685
400	GMM 400 L 8c	745	845	5127,5	0,75	96,3	95,2	92	6,1	2	1,8	0,6	2,4	29	2835
450	GMM 400 L 8d	745	914	5768,5	0,75	93,5	94	94	6,2	2,1	1,8	0,6	2,5	32	3010
500	GMM 450 L 8a	745	541	6409,4	0,81	93,5	94	94	6,6	2,2	2	0,7	2,4	37	3800
560	GMM 450 L 8b	745	603	7178,5	0,81	93,5	94	94	6,6	2,2	2	0,7	2,4	41	4000
630	GMM 450 H 8c	745	675	8075,8	0,82	93,5	94	94	6,6	2,2	2	0,7	2,4	46	4200

*Nominal current at 690 V.

Efficiency values are calculated by the indirect measurement method in accordance with IEC 60034-2-1: 2014 standard. Additional losses are assessed based on test results performed at variable load values.



OPERATIONAL CHARACTERISTICS

3 Phase, 400 V, 50 Hz | Type of Operation: S1 (Continuous Operation)
 Protection Degree: IP 55 | Insulation Class: H (180°C) | Heat Increase Limit: B (80K)

Standard Series
 Three Phase Motors

IE3

CAST IRON FRAME

2 poles - 3000 RPM

Nominal Power	Type	At Nominal Power							At Start-up				Tilting Moment Ratio	Moment of Inertia	Approx. Weight
		Speed	Current	Torque	Power Coefficient Cos φ	Efficiency η			Current Ratio		Torque Ratio				
		RPM	A	Nm		4/4	3/4	1/2	Direct	Y/Δ	Direct	Y/Δ			
55	GM3E 250 M 2a	2985	92	176	0,92	94,3	94,5	93,3	8,7	2,9	2,9	1	3	0,47	480
75	GM3E 280 S 2a	2985	127	239,9	0,9	94,7	94,6	94	8	2,7	2,9	1	3,2	0,62	585
90	GM3E 280 M 2b	2985	148	287,9	0,92	95	95	93,7	8,2	2,7	2,9	1	3	0,74	645
110	GM3E 315 S 2a	2985	186	351,9	0,9	95,2	95,2	94	8	2,7	2,5	0,8	3	1,2	742
132	GM3E 315 M 2b	2985	223	422,3	0,9	95,4	95,4	94,1	8	2,7	2,4	0,8	3,5	1,4	812
160	GM3E 315 M 2c	2985	265	511,9	0,91	95,6	95,6	94,2	8	2,7	2,5	0,8	3	1,5	912
185	GMM3E 315 L 2d	2985	304	591,9	0,92	95,8	95,7	94,2	7,5	2,5	2,5	0,8	2,8	1,8	1110
200	GMM3E 315 L 2e	2985	324	639,9	0,93	95,8	95,8	94,6	7,5	2,5	2,5	0,8	2,8	1,8	1110
250	GM3E 315 H 2f	2990	410	798,5	0,92	95,8	95,8	94,6	7,5	2,5	2,5	0,8	2,8	1,8	1200
250	GMM3E 355 M 2a	2990	413	798,5	0,91	95,8	95,8	94,6	7	2,3	2	0,7	2,5	3,6	1170
315	GMM3E 355 M 2b	2990	516	1006,1	0,92	95,8	95,8	94,7	7	2,3	2	0,7	2,5	4,5	1360
355	GMM3E 355 M 2c	2990	575	1133,9	0,93	95,8	95,7	94,8	7,2	2,4	2	0,7	2,5	4,7	1420
400	GMM3E 355 L 2d	2990	660	1277,6	0,92	95,8	95,8	94,9	7	2,3	2	0,7	2,5	5,3	1630

Efficiency values are calculated by the indirect measurement method in accordance with IEC 60034-2-1: 2014 standard. Additional losses are assessed based on test results performed at variable load values.

IE3

OPERATIONAL CHARACTERISTICS

3 Phase, 400 V, 50 Hz | Type of Operation: S1 (Continuous Operation)
 Protection Degree: IP 55 | Insulation Class: F (155°C) | Heat Increase Limit: B (80K)

CAST IRON FRAME

4 poles - 1500 RPM

Nominal Power	Type	At Nominal Power							At Start-up				Tilting Moment Ratio	Moment of Inertia	Approx. Weight
		Speed	Current	Torque	Power Coefficient Cos φ	Efficiency η			Current Ratio		Torque Ratio				
		RPM	A	Nm		4/4	3/4	1/2	Direct	Y/Δ	Direct	Y/Δ			
55	GM3E 250 M 4a	1480	96	354,9	0,87	94,6	94,7	94	7,7	2,6	3,2	1,1	3	0,78	445
75	GM3E 280 S 4a	1485	133	482,3	0,86	95	94,9	94,4	7,6	2,5	2,9	1	1	1,11	605
90	GM3E 280 M 4b	1485	158	578,8	0,86	95,2	95,2	94,8	7,4	2,5	2,9	1	3	1,32	665
110	GM3E 315 S 4a	1490	194	705	0,86	95,4	95,2	95	7,4	2,5	2,4	0,8	3	2,5	861
132	GM3E 315 M 4b	1490	226	846	0,88	95,6	95,4	95,3	7,4	2,5	2,4	0,8	3	2,8	882
160	GM3E 315 L 4c	1490	275	1025,5	0,88	95,8	95,6	95,6	6,9	2,3	2,2	0,7	2,9	3	930
185	GM3E 315 L 4d	1490	321	1185,7	0,87	96	96	95,8	6,9	2,3	2,2	0,7	2,9	3,1	1015
200	GM3E 315 H 4e	1490	350	1281,9	0,86	96	95,8	95,8	7,5	2,5	2,5	0,8	3,1	3,3	1100
250	GM3E 315 H 4f	1490	435	1602,3	0,86	96	95,8	95,8	7,6	2,5	2,3	0,8	3,1	3,5	1200
250	GMM3E 355 M 4a	1490	430	1602,3	0,87	96	96	96	7,2	2,4	2,2	0,7	3	6	1400
315	GMM3E 355 M 4b	1490	540	2019	0,88	96	96	95,9	7,2	2,4	2,2	0,7	3	6,5	1438
355	GMM3E 355 L 4c	1490	610	2275,3	0,87	96	96	96,1	7,2	2,4	2,2	0,7	3	7,2	1490
400	GMM3E 355 L 4d	1490	690	2563,8	0,87	96	96,1	96	7,2	2,4	2,2	0,7	3	7,9	1720

Efficiency values are calculated by the indirect measurement method in accordance with IEC 60034-2-1: 2014 standard. Additional losses are assessed based on test results performed at variable load values.

OPERATIONAL CHARACTERISTICS

3 Phase, 400 V, 50 Hz | Type of Operation: S1 (Continuous Operation)
Protection Degree: IP 55 | Insulation Class: H (180°C) | Heat Increase Limit: B (80K)

CAST IRON FRAME

6 poles - 1000 RPM

Nominal Power kW	Type	At Nominal Power							At Start-up				Tilting Moment Ratio	Moment of Inertia	Approx. Weight
		Speed RPM	Current A	Torque Nm	Power Coefficient Cos φ	Efficiency η			Current Ratio		Torque Ratio				
						4/4	3/4	1/2	Direct	Y/Δ	Direct	Y/Δ			
37	GM3E 250 M 6a	985	70	358,7	0,82	93,3	93,2	92,9	7	2,3	2,8	0,9	2,6	0,99	440
45	GM3E 280 S 6a	990	88	434,1	0,79	93,7	93,7	92,9	6,9	2,3	3	1	2,8	1,5	553
55	GM3E 280 M 6b	990	112	530,6	0,75	94,1	94,1	92,8	7,3	2,4	3,3	1,1	3,2	1,7	578
75	GM3E 315 S 6a	990	140	723,5	0,82	94,6	94,6	94,4	7,2	2,4	2,7	0,9	3	2,9	805
90	GM3E 315 M 6b	990	166	868,2	0,82	94,9	94,9	94,5	7,2	2,4	2,7	0,9	3	3,5	860
110	GM3E 315 M 6c	990	198	1061,1	0,84	95,1	95,1	94,9	7,2	2,4	2,7	0,9	3	4,2	980
132	GMM3E 315 L 6d	990	235	1273,3	0,85	95,4	95,4	95,2	7,2	2,4	2,7	0,9	3	4,3	1150
160	GM3E 315 H 6e	990	288,5	1543,4	0,84	95,6	95,6	95,2	8,5	2,8	2,7	0,9	3,2	4,5	1200
160	GMM3E 355 M 6a	995	290	1535,7	0,83	95,6	95,6	95	7	2,3	2,4	0,8	3,2	6,8	1185
200	GMM3E 355 M 6b	995	345	1919,6	0,87	95,8	95,8	95,3	7	2,3	2,4	0,8	3,2	8,3	1390
250	GMM3E 355 L 6c	995	437	2399,5	0,86	95,8	95,8	95,4	7	2,3	2,4	0,8	3,2	10,4	1716
315	GMM3E 355 L 6d	995	555	3023,4	0,86	95,8	95,7	95,5	7	2,3	2,4	0,8	3,2	11,7	1890
355	GMM3E 400 L 6a	995	610	3407,3	0,88	95,8	95,8	95,7	6,8	2,3	2,2	0,7	2,9	23,6	2450
400	GMM3E 400 L 6b	995	690	3839,2	0,87	95,8	95,8	95,7	6,8	2,3	2,2	0,7	2,9	26,6	2705

For the asynchronous motors, motors where two or more powers and speeds can be obtained from a single structure size are called "multi-speed motors". Generally, they are manufactured with two different powers and speeds obtained from a single winding placed in the stator or from two separate windings.

These motors are divided into two groups according to the winding shape;

Motors with Dahlander Connection:

These are the motors that can obtain two different rotations in the ratio of 1:2 from a single winding placed on the stator. The motors with 4/2 and 8/4 poles on the Operational Characteristics pages are Dahlander winding motors.

Motors with Two Different Windings:

These motors consist of 2 different windings placed on the stator for 2 different rotations. This design is generally used in situations where pole ratios are unsuitable. 6/4 pole motors on the Operational Characteristics pages are motors with two different windings.

Please consult for the manufacture of 3 or 4 speed motors that can be obtained by using both winding designs together. Dual speed motors are generally designed for two different applications:

- Constant load torque (constant torque)
- Load torque proportional to the square of the speed (variable torque)

Constant Torque

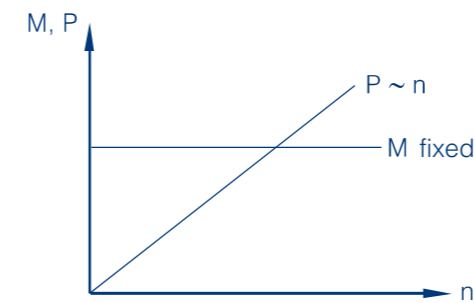

Constant torque applications include compressors, machine tools and cranes that require high torque at start-up and constant torque at low speed. The high torque requirement of the motors designed according to these applications is met by keeping the output power at low speed as high as possible.

Variable Torque

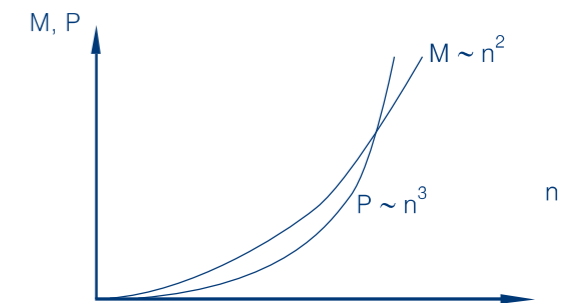

Variable torque applications include pumps and fans that do not require high torque at start-up and whose torque requirement at low-speed decreases with the square of the speed. For motors designed for these applications, when the speed ratio is 1:2, the power ratio is approximately 1:4, and when the speed ratio is 3:2, the power ratio is approximately 1:3.

For Dahlander winding motors, Δ/YY connection is made for constant torque and Y / YY connection is made for variable torque. Y / Y connection is made in both applications for motors with two separate windings. Terminal end connections of motors are as follows;

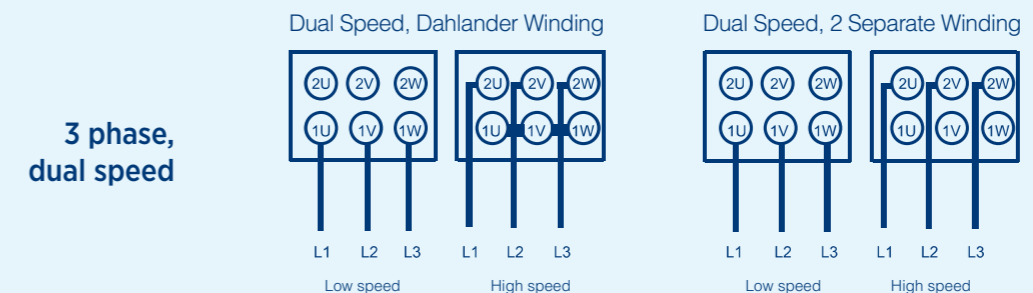

Efficiency values are calculated by the indirect measurement method in accordance with IEC 60034-2-1: 2014 standard. Additional losses are assessed based on test results performed at variable load values.

standard series- three phase motors

DOUBLE SPEED MOTORS

OPERATIONAL CHARACTERISTICS

3 Phase, 400 V, 50 Hz | Type of Operation: S1 (Continuous Operation)
Protection Degree: IP 55 | Insulation Class: H (180°C) | Heat Increase Limit: B (80K)

ALUMINUM FRAME

4/2 poles - 1500/3000 RPM

Load torque constant (Machine Tools) Single Winding - Dahlander Connection Δ/YY

Nominal Power	Type	At Nominal Power					At Start-up		Tilting Moment Ratio	Moment of Inertia J	Approx. Weight B3
		Speed	Current I _N	Torque M _N	Power Coefficient Cos φ	Efficiency η %	Current Ratio I _A / I _N	Torque Ratio M _A / M _N			
kW	RPM	A	Nm								
0,06/0,08	AGM 56 4/2a	1360/2750	0,40/0,46	0,42/0,28	0,49/0,5	42,7/48,5	2,6/2,9	1,9/2,1	2/2,2	0,00011	2,7
0,08/0,1	AGM 56 4/2b	1360/2750	0,43/0,48	0,56/0,35	0,58/0,56	44,6/52,4	2,8/3,1	2/2,2	2,1/2,3	0,00012	2,8
0,11/0,15	AGM 63 4/2a	1390/2800	0,50/0,50	0,76/0,51	0,68/0,73	45,6/57,3	2,8/3,5	1,8/1,9	1,9/2,3	0,00017	3,2
0,15/0,22	AGM 63 4/2b	1390/2800	0,67/0,64	1,03/0,75	0,66/0,81	47,6/59,3	2,7/3,7	1,9/1,8	2,3/2,2	0,00021	3,7
0,22/0,3	AGM 71 4/2a	1375/2750	0,70/0,85	1,5/1	0,73/0,84	60,3/59,4	3,0/3,3	1,5/1,4	1,9/1,8	0,00040	4,9
0,3/0,44	AGM 71 4/2b	1390/2800	0,95/1,2	2,1/1,5	0,72/0,81	61,3/63,3	3/3,1	1,5/1,3	2/1,8	0,00054	5,9
0,5/0,6	AGM 80 4/2a	1370/2780	1,4/1,6	3,5/2,1	0,79/0,86	63,3/61,4	3/3,5	1,4/1,5	1,7/2	0,00083	7,6
0,7/0,85	AGM 80 4/2b	1370/2800	2/2,3	4,9/2,9	0,75/0,76	65,3/68,3	3,3/4,	1,7/2	2/2,3	0,0011	8,7
1/1,3	AGM 90 S 4/2	1370/2750	2,5/3,3	7/4,5	0,81/0,85	69,3/65,4	3,8/3,7	1,7/1,7	2/1,8	0,0019	11,5
1,3/1,8	AGM 90 L 4/2	1390/2800	3/4,3	8,9/6,1	0,85/0,86	72,2/68,4	4,4/4,2	2/1,9	2,2/2	0,0024	13,6
1,8/2,2	AGM 100 L 4/2a	1420/2840	4,1/5,5	12,1/7,4	0,82/0,8	75,2/70,4	4,9/4,5	2/2,1	2,3/2,4	0,0038	17,3
2,4/3	AGM 100 L 4/2b	1390/2820	5,2/6,8	16,5/10,2	0,83/0,84	78,2/74,3	4,7/4,9	2/2,1	2,2/2,3	0,0050	20,8
3,7/4,5	AGM 112 M 4/2	1430/2880	7,6/10	25/15	0,86/0,82	80,2/77,3	5,6/5,3	1,9/1,9	2,3/2,4	0,0092	28,7
4,5/5,5	AGM 132 S 4/2	1430/2860	9,5/14	30/18	0,84/0,77	79,3/74,4	5,4/5,1	2/1,9	2,2/2,2	0,019	39
6,3/7,5	AGM 132 M 4/2	1440/2880	12,6/17	42/25	0,88/0,81	80,3/77,4	5,6/6,	2,3/2,4	2,5/2,6	0,026	47
7,5/10	C.AGM 132 M 4/2	1440/2890	15/21	50/33	0,85/0,86	81,3/78,4	6,4/6,4	2,5/2,1	3,1/3,1	0,032	56
9/11	AGM 160 M 4/2	1450/2900	18/23	59/36	0,86/0,88	84,3/78,4	6,2/6,3	2,3/2,4	2,4/2,6	0,054	74
12,5/15	AGM 160 L 4/2	1465/2930	24/29	81/49	0,85/0,88	86,3/83,4	5,6/6,9	2,2/2,4	2,2/2,5	0,072	104
17/20	AGM 180 L 4/2	1455/2930	33/39	112/65	0,85/0,9	85,4/80,5	6,2/7,2	2,5/2,7	2,6/3	0,13	143
21/25	AGM 200 L 4/2	1460/2920	40/46	137/82	0,89/0,9	83,5/85,5	6,6/6,8	2,4/2,6	2,4/2,7	0,19	185
25/30	C.AGM 200 L 4/2	1460/2915	45/56	164/98	0,91/0,9	86,4/84,5	6,4/6,6	2/2,2	2,3/2,6	0,23	205

CAST IRON FRAME

4/2 poles - 1500/3000 RPM

4,5/5,5	GM 132 S 4/2	1430/2860	9,5/14	30/18	0,84/0,77	79,3/74,4	5,4/5,1	2/1,9	2,2/2,2	0,019	51
6,3/7,5	GM 132 M 4/2	1440/2880	12,6/17	42/25	0,88/0,81	80,3/77,4	5,6/6	2,3/2,4	2,5/2,6	0,026	60
9/11	GM 160 M 4/2	1450/2900	18/23	59/36	0,86/0,88	84,3/78,4	6,2/6,3	2,3/2,4	2,4/2,6	0,054	105
12,5/15	GM 160 L 4/2	1465/2930	24/29	81/49	0,85/0,88	86,3/83,4	5,6/6,9	2,2/2,4	2,2/2,5	0,072	140
17/20	GM 180 L 4/2	1455/2930	33/39	112/65	0,85/0,9	85,4/80,5	6,2/7,2	2,5/2,7	2,6/3	0,13	170
21/25	GM 200 L 4/2	1460/2920	40/46	137/82	0,89/0,9	83,5/85,5	6,6/6,8	2,4/2,6	2,4/2,7	0,19	235
25/30	C.GM 200 L 4/2	1460/2915	45/56	164/98	0,91/0,9	86,4/84,5	6,4/6,6	2/2,2	2,3/2,6	0,23	255
31/37	GM 225 M 4/2	1460/2915	56/70	203/121	0,88/0,89	89,4/84,5	5,6/5,6	1,9/1,9	2/2,3	0,35	320
39/45	GM 250 M 4/2	1465/2935	72/78	254/146	0,87/0,94	88,5/87,5	6,1/6,9	2,3/2,6	2,3/2,8	0,54	395
46/55	C.GM 250 M 4/2	1465/2935	81/96	300/179	0,9/0,93	89,5/87,6	6,2/7	2,3/2,6	2,3/2,8	0,72	450
56/67	GM 280 M 4/2	1480/2970	100/121	361/215	0,88/0,91	90,5/86,6	8/8,6	2,8/2,6	2,8/3,3	1,1	615
72/32	C.GM 280 M 4/2	1480/2970	129/148	465/264	0,88/0,91	90,6/86,7	8/8,6	2,4/2	2,4/2,8	1,3	665
77/90	GM 315 S 4/2	1485/2980	148/153	495/288	0,81/0,93	91,6/89,6	7/7,5	2,2/2,1	2,5/2,6	0,96	720
94/110	GM 315 M 4/2a	1485/2980	181/186	605/353	0,81/0,93	92,6/90,7	8,6/8,8	2,4/2,3	2,7/2,8	1,2	805
12C/140	GM 315 M 4/2b	1485/2980	225/231	772/449	0,82/0,94	92,6/91,7	7,6/8,8	2,1/2	2,5/2,6	1,4	870
132/155	GMM 315 L 4/2a	1485/2980	247/255	849/497	0,82/0,94	92,7/91,7	8,6/8,8	2,2/2,1	2,5/2,6	1,42	920
143/168	GMM 315 L 4/2b	1485/2980	282/276	920/538	0,78/0,94	92,7/91,7	8,6/8,8	2,4/2,3	2,8/2,9	1,5	950



In constant torque applications, dual speed motors must be started first at low speed depending on the torque characteristic. They can be switched to high-speed after reaching the rated speed.



In constant torque applications, motors with Dahlander connection are started directly, but special connection suitable for Y / start-up can be made upon request.

Efficiency values are calculated by the indirect measurement method in accordance with the IEC 60034-2-1: 2014 standard. Additional losses are assessed based on test results performed at variable load values.

standard series- three phase motors

DOUBLE SPEED MOTORS

OPERATIONAL CHARACTERISTICS

3 Phase, 400 V, 50 Hz | Type of Operation: S1 (Continuous Operation)
Protection Degree: IP 55 | Insulation Class: F (155°C) | Heat Increase Limit: B (80K)

ALUMINUM FRAME

8/4 poles - 750/1500 RPM

Load torque constant (Machine Tools) Single Winding - Dahlander Connection Δ/YY

Nominal Power	Type	At Nominal Power					At Start-up		Tilting Moment Ratio	Moment of Inertia J	Approx. Weight B3
		Speed	Current I _N	Torque M _N	Power Coefficient Cos φ	Efficiency η %	Current Ratio I _A / I _N	Torque Ratio M _A / M _N			
kW	RPM	A	Nm								
0,15/0,25	AGM 71 8/4	680/1380	0,65/0,7	2,1/1,7	0,71/0,81	45,7/62,3	2,3/3,1	1,5/1,4	1,8/1,7	0,00086	6,3
0,200/37	AGM 80 8/4a	690/1400	1,1/0,9	3,6/2,5	0,63/0,84	52,5/69,1	2,6/4,2	1,6/1,7	1,9/2	0,0017	8,1
0,35/0,55	AGM 80 8/4b	670/1370	1,4/1,5	5/3,8	0,62/0,77	56,5/67,2	2,6/3,7	1,8/1,7	2/2	0,0022	9,4
0,4/0,7	AGM 90 S 8/4	690/1380	1,6/1,7	5,5/4,8	0,59/0,83	59,4/69,2	2,9/3,7	1,6/1,4	2/1,6	0,0029	11,3
0,6/0,9	AGM 90 L 8/4	680/1365	2,1/2,2	8,4/6,3	0,68/0,84	59,4/68,3	2,8/3,8	1,4/1,5	1,7/1,7	0,0038	13,5
0,75/1,1	AGM 100 L 8/4a	690/1400	2,4/2,6	10,4/7,5	0,69/0,85	63,4/70,3	3,2/4,4	1,6/1,8	1,9/2,1	0,0062	17,7
1/1,6	AGM 100 L 8/4b	690/1395	3,4/3,5	13,8/11	0,63/0,9	65,4/71,3	3,1/4,3	1,8/1,7	2,1/2	0,0084	19,6
1,5/2,5	AGM 112 M 8/4	705/1400	4,4/5,1	20,3/17,1	0,67/0,88	71,3/78,2	3,8/4,2	1,9/1,7	2,4/2,2	0,013	26,5
2,2/3,4	AGM 132 S 8/4	700/1400	6,9/7,4	30/23	0,65/0,87	69,4/74,3	3,6/4,8	1,8/1,8	2,1/1,9	0,024	35
3,5/5,5	AGM 132 M 8/4	700/1400	10/11,2	48/38	0,68/0,9	72,4/77,4	3,8/5,3	1,8/1,7	2/2	0,033	43
4,5/6	AGM 160 M 8/4a	715/1425	11/12,7	60/40	0,74/0,87	78,3/76,4	4,3/5,1	1,7/1,7	2/2,2	0,060	63
5,5/7,5	AGM 160 M 8/4b	715/1435	13/15,7	73/50	0,75/0,86	79,3/78,4	5,2/6,1	2,2/2,2	2,4/2,4	0,083	73
7,5/11	AGM 160 L 8/4	720/1440	17/22	99/73	0,77/0,88	81,3/80,4	5/5,8	2,1/2,4	2,4/2,4	0,12	102
11/15	AGM 180 L 8/4	720/1450	24/30	146/99	0,78/0,86	83,4/82,4	5,8/7	2,3/2,6	2,7/2,9	0,20	138
16/24	C.AGM 200 L 8/4	725/1460	38/44	211/157	0,71/0,89	84,4/86,4	4,8/6,2	2,3/1,9	2,4/2,3	0,23	205

CAST IRON FRAME

8/4 poles - 750/1500 RPM

2,2/3,4	GM 132 S 8/4	700/1400	6,9/7,4	30/23,2	0,65/0,87	69,4/74,3	3,6/4,8	1,8/1,8	2,1/1,9	0,024	47
3,5/5,5	GM 132 M 8/4	700/1400	10/11,2	48/38	0,68/0,9	72,4/77,4	3,8/5,3	1,8/1,7	2/2	0,033	56
4,5/6	GM 160 M 8/4a	715/1425	11/12,7	60/40	0,74/0,87	78,3/76,4	4,3/5,1	1,7/1,7	2/2,2	0,060	95
5,5/7,5	GM 160 M 8/4b	715/1435	13/15,7	73/50	0,75/0,86	79,3/78,4	5,2/6,1	2,2/2,2	2,4/2,4	0,083	105
7,5/11	GM 160 L 8/4	720/1440	17/22	99/73	0,77/0,88	81,3/80,4	5,0/5,8	2,1/2,4	2,4/2,4	0,12	134
11/15	GM 180 L 8/4	720/1450	24/30	146/99	0,78/0,86	83,4/82,4	5,8/7,0	2,3/2,6	2,7/2,9	0,20	165
16/24	C.GM 200 L 8/4	725/1460	38/44	211/157	0,71/0,89	84,4/86,4	4,8/6,2	2,3/1,9	2,4/2,3	0,23	255
18,5/32	GM 225 M 8/4	730/1460	49/58	242/209	0,63/0,89	84,4/87,5	3,9/5,4	2,2/2	2,1/2,2	0,35	320
23/40	C.GM 225 M 8/4	730/1470	59/72	301/260	0,65/0,9	85,4/87,5	4,4/5,7	2,4/2,2	2,2/2,3	0,44	360
30/48	C.GM 250 M 8/4	730/1470	77/84	392/312	0,65/0,91	84,5/89,5	4,3/6,4	2,2/2,1	1,9/2,4	0,72	450
37/55	GM 280 M 8/4	740/1480	95/97	478/355	0,65/0,9	85,5/89,5	4,5/6,4	1,6/1,6	1,4/1,8	1,1	615
45/66	C.GM 280 M 8/4	735/1480	110/122	585/426	0,66/0,85	87,5/90,6	4,7/6,6	1,8/2,1	1,6/2,1	1,3	665
55/75	GM 315 S 8/4	740/1485	113/133	710/482	0,76/0,89	90,5/89,6	5,5/6,7	2/1,9	1,9/2	2	695
65/90	GM 315 M 8/4a	740/1485	129/176	839/579	0,78/0,8	91,5/90,6	6,3/6,1	2/1,9	1,9/2	2,5	745
80/110	GM 315 M 8/4b	740/1485	163/195	1032/707	0,76/0,89	91,6/90,7	7/8	2,4/2,2	2,3/2,3	3	820
90/125	GMM 315 L 8/4	740/1485	179/220	1154/804	0,8/0,91	89,6/88					

standard series- three phase motors

DOUBLE SPEED MOTORS

OPERATIONAL CHARACTERISTICS

3 Phase, 400 V, 50 Hz | Type of Operation: S1 (Continuous Operation)
Protection Degree: IP 55 | Insulation Class: H (180°C) | Heat Increase Limit: B (80K)

ALUMINUM FRAME

6/4 poles - 1000/1500 RPM

Constant Load Torque (Machine Tools) Two Different Windings Y/Y

Nominal Power kW	Type	At Nominal Power					At Start-up		Tilting Moment Ratio M _k / M _N	Moment of Inertia J kgm ²	Approx. Weight B3 kg
		Speed RPM	Current I _N A	Torque M _N Nm	Power Coefficient Cos φ	Efficiency η % IEC 60034-2-1:2007	Current Ratio I _A / I _N Direct	Torque Ratio M _A / M _N Direct			
0,12/0,16	AGM 71 6/4a	920/1370	0,7/0,72	1,25/1,12	0,59/0,67	40,8/46,6	3,1/2,6	1,3/1,3	1,7/1,6	0,00064	5,4
0,18/0,22	AGM 71 6/4b	920/1370	0,8/0,9	1,87/1,53	0,71/0,65	44,7/52,5	3,2/2,8	1,4/1,4	1,7/1,6	0,00086	6,3
0,18/0,33	AGM 80 6/4a	930/1410	0,9/1,1	2,57/2,24	0,85/0,73	45,7/57,4	3,1/3,2	1,5/1,5	2/2,1	0,0017	8,1
0,3/0,4	AGM 80 6/4b	930/1425	1/1,2	3,08/2,68	0,85/0,77	47,7/59,4	3,4/4,3	1,8/2	2,2/2,5	0,0022	9,4
0,45/0,6	AGM 90 S 6/4	940/1430	1,5/1,8	4,6/4	0,7/0,79	60,4/59,4	3,3/3,8	1,4/1,6	1,8/2,1	0,0029	11,3
0,6/0,9	AGM 90 L 6/4	950/1420	2/2,5	6/6,1	0,69/0,8	61,4/63,4	3,9/3,3	1,7/1,5	2,4/1,9	0,0038	13,5
1,2/1,7	AGM 100 L 6/4	950/1425	3,4/4,2	12,1/11,4	0,74/0,85	67,3/67,4	3,7/4,1	1,8/1,7	2/1,9	0,0084	19,3
1,5/2,4	AGM 112 M 6/4	950/1435	4/5,6	15,1/16	0,74/0,79	71,3/76,2	4,6/4,8	1,9/1,7	2,4/2,2	0,013	26,5
2,2/3,3	AGM 132 S 6/4	965/1445	5,6/7,6	21,8/21,8	0,77/0,84	72,3/73,4	4,8/5	1,9/1,7	2,6/2,3	0,022	36
3,2/5	AGM 132 M 6/4	960/1450	7,6/11	31,8/32,9	0,77/0,8	77,3/80,3	5,6/6,1	2,3/1,9	2,5/2,2	0,043	49,5
5/7,5	AGM 160 M 6/4	970/1455	10,5/15	49,2/49,2	0,86/0,89	78,3/79,4	5,5/5,8	1,8/1,7	2,5/2,5	0,079	81
6,5/10	AGM 160 L 6/4	965/1450	13,3/19	64,3/65,9	0,87/0,9	79,3/82,4	5,4/6,4	1,8/1,9	2,4/2,5	0,11	95
9,5/15	AGM 180 L 6/4	970/1460	19/28	93,5/98,1	0,86/0,91	82,3/83,4	6,5/6,9	1,7/1,8	2,7/2,9	0,16	145
15/23	AGM 200 L 6/4	970/1470	31/43	148/149	0,82/0,88	83,4/86,4	7,1/7,5	2,1/1,9	3/3	0,26	185

CAST IRON FRAME

6/4 poles - 1000/1500 RPM

2,2/3,3	GM 132 S 6/4	965/1445	5,6/7,6	22/22	0,77/0,84	72,3/73,4	4,8/5	1,9/1,7	2,6/2,3	0,022	48
3,2/5	GM 132 M 6/4	960/1450	7,6/11	32/33	0,77/0,8	77,3/80,3	5,6/6,1	2,3/1,9	2,5/2,2	0,043	62
5/7,5	GM 160 M 6/4	970/1455	10,5/15	49/49	0,86/0,89	78,3/79,4	5,5/5,8	1,8/1,7	2,5/2,5	0,079	115
6,5/10	GM 160 L 6/4	965/1450	13,3/19	64/66	0,87/0,9	79,3/82,4	5,4/6,4	1,8/1,9	2,4/2,5	0,11	125
9,5/15	GM 180 L 6/4	970/1460	19/28	94/98	0,86/0,91	82,3/83,4	6,5/6,9	1,7/1,8	2,7/2,9	0,16	175
15/23	GM 200 L 6/4	970/1470	31/43	148/149	0,82/0,88	83,4/86,4	7,1/7,5	2,1/1,9	3/3	0,26	235
22/32	GM 225 M 6/4	980/1470	43/57	214/208	0,84/0,91	86,4/87,5	5,8/7	2,4/2,4	2,1/2,4	0,57	330
26/39	GM 250 M 6/4	980/1475	53/72	253/253	0,80/0,88	86,5/87,5	6,7/6	2,6/2,2	2,2/2,2	0,77	395
39/57	GM 280 S 6/4	985/1475	78/108	378/369	0,81/0,86	87,5/87,6	6,3/5,5	2,5/2,1	2,3/2,2	1,2	550
46/66	GM 280 M 6/4	990/1485	91/131	444/424	0,81/0,81	88,5/88,6	6,8/6,2	2,5/2,1	2,3/2,2	1,5	610
52/75	GM 315 S 6/4	990/1485	95/135	502/482	0,88/0,89	88,5/88,6	6,2/6	1,6/1,6	2,3/2,3	2	695
58/85	GM 315 M 6/4a	990/1480	110/158	559/548	0,84/0,85	89,6/89,6	7,9/5,5	1,8/1,6	2/1,9	2,5	745
75/110	GM 315 M 6/4b	990/1485	141/190	723/707	0,83/0,91	90,6/90,7	8,2/7,2	1,8/1,6	1,9/1,8	3	820
86/125	GMM 315 L 6/4	990/1485	160/210	830/804	0,83/0,92	91,6/91,7	8/6	1,8/1,6	1,9/1,8	4	860

! In constant torque applications, dual speed motors must be started first at low speed depending on the torque characteristic. They can be switched to high-speed after reaching the rated speed.

! In constant torque applications, motors with Dahlander connection are started directly, but special connection suitable for Y / start-up can be made upon request.

Efficiency values are calculated by the indirect measurement method in accordance with the IEC 60034-2-1: 2014 standard. Additional losses are assessed based on test results performed at variable load values.

standard series- three phase motors

DOUBLE SPEED MOTORS

OPERATIONAL CHARACTERISTICS

3 Phase, 400 V, 50 Hz | Type of Operation: S1 (Continuous Operation)
Protection Degree: IP 55 | Insulation Class: H (180°C) | Heat Increase Limit: B (80K)

ALUMINUM FRAME

4/2 poles - 1500/3000 RPM

Load Torque Proportional to the Square of the Speed (Pump and Ventilator) - Dahlander Connection Y/YY

Nominal Power kW	Type	At Nominal Power					At Start-up		Tilting Moment Ratio M _k / M _N	Moment of Inertia J kgm ²	Approx. Weight B3 kg
		Speed RPM	Current I _N A	Torque M _N Nm	Power Coefficient Cos φ	Efficiency η % IEC 60034-2-1:2007	Current Ratio I _A / I _N Direct	Torque Ratio M _A / M _N Direct			
0,035/0,14	V. AGM 63 4/2a	1400/2860	0,2/0,5	0,24/0,47	0,51/0,62	48,4/63,2	3,2/4,5	2,1/2,4	2,4/2,8	0,00011	3,3
0,05/0,19	V. AGM 63 4/2b	1420/2880	0,22/0,6	0,34/0,63	0,66/0,74	48,5/60,3	3,4/4,8	2,3/2,7	2,6/3	0,00013	3,7
0,08/0,37	V. AGM 71 4/2a	1380/2800	0,32/1,1	0,55/1,26	0,69/0,84	50,5/56,5	2,5/3,5	1,4/1,5	1,6/1,7	0,00026	5,1
0,12/0,5	V. AGM 71 4/2b	1380/2800	0,45/1,4	0,83/1,71	0,73/0,81	51,5/62,3	3,0/3,8	1,6/1,8	1,8/2	0,00034	6,3
0,17/0,75	V. AGM 80 4/2a	1400/2790	0,5/1,7	1,2/2,6	0,77/0,91	62,2/68,3	3,5/4,1	1,6/1,7	1,9/1,9	0,00053	7,8
0,25/1,0	V. AGM 80 4/2b	1410/2810	0,7/2,2	1,7/3,4	0,75/0,98	67,1/65,4	3,3/3,6	1,4/1,6	1,7/1,9	0,00066	8,9
0,33/1,3	V. AGM 90 S 4/2	1425/2860	0,9/2,8	2,2/4,3	0,74/0,87	70,1/75,2	3,7/4,4	1,6/1,8	2/1,9	0,0011	11,4
0,5/2,0	V. AGM 90 L 4/2	1415/2835	1,2/4,2	3,4/6,7	0,78/0,88	75,0/76,2	4,5/6	2,0/1,8	2,4/2,5	0,0014	13,8
0,66/2,7	V. AGM 100 L 4/2	1430/2845	1,5/5,2	4,4/9,1	0,81/0,95	76,0/77,2	4,9/4,7	1,7/1,9	2,3/2,1	0,0024	17,3
0,9/3,6	V. AGM 112 M 4/2	1440/2870	2/7,3	6,0/12	0,83/0,89	76,1/78,3	5,5/6	1,8/2	2,6/2,5	0,0039	27
1,25/5	V. AGM 132 S 4/2a	1440/2860	3/9,8	8,3/16,7	0,81/0,93	75,2/77,3	4,3/4,9	1,8/2,1	2/2,2	0,0090	33
1,7/6,5	V. AGM 132 S 4/2b	1440/2900	3,6/12,5	11,3/21,4	0,84/0,89	79,1/82,3	5,8/6,8	2,3/2,3	2,5/2,7	0,012	39
2,5/10	V. AGM 160 M 4/2a	1450/2910	5,3/19,5	16/33	0,84/0,9	79,2/80,4	5/5,3	2/2,5	2,2/2,7	0,026	62
3,3/13	V. AGM 160 M 4/2b	1460/2930	6,7/24	22/42	0,85/0,91	82,2/84,4	6,8/8,6	2,2/2,5	2,9/3,3	0,034	73
4,4/17	V. AGM 160 L 4/2	1460/2930	8,6/32	29/55	0,87/0,89	83,2/84,4	6,9/8,8	2,4/2,6	2,7/3	0,041	86
5/20	V. AGM 180 M 4/2	1475/2940	10/37	32/65	0,87/0,9	81,3/85,4	6,7/7,7	2,6/2,4	2,7/2,7	0,060	125
7,5/28	V. AGM 200 L 4/2a	1470/2960	15/50	49/90	0,85/0,92	83,3/86,5	6,4/7,5	2,3/2,1	2,3/2,4	0,10	165
8,5/33	V. AGM 200 L 4/2b	1470/2950	16/59	55/107	0,87/0,9	86,2/88,5	6,8/7,6	2,1/1,9	2,2/2,1	0,13	185

CAST IRON FRAME

4/2 poles - 1500/3000 RPM

1,25/5	V. GM 132 S 4/2a	1440/2860	3/9,8	8,3/16,7	0,78/0,93	75,2/77,3	4,3/4,9	1,8/2,1	2/2,2	0,0090	45
1,7/6,5	V. GM 132 S 4/2b	1440/2900	3,6/12,5	11,3/21,4	0,84/0,89	79,1/82,3	5,8/6,8	2,3/2,3	2,5/2,7	0,012	52
2,5/10	V. GM 160 M 4/2a	1450/2910	5,3/19,5	16,5/32,8	0,84/0,9	79,2/80,4	5,0/5,3	2/2,5	2,2/2,7	0,026	94
3,3/13	V. GM 160 M 4/2b	1460/2930	6,7/24	21,6/42,4	0,85/0,91	82,2/84,4	6,8/8,6	2,2/2,5	2,9/3,3	0,034	105
4,4/17	V. GM 160 L 4/2	1460/2930	8,6/32	28,8/55,4	0,87/0,89	83,2/84,4	6,9/8,8	2,4/2,6	2,7/3,0	0,041	118
5/20	V. GM 180 M 4/2	1475/2940	10/37	32,4/65	0,87/0,9	81,3/85,4	6,7/7,7	2,6/2,4	2,7/2,7	0,060	150
7,5/28	V. GM 200 L 4/2a	1470/2960	15/50	48,7/90,3	0,85/0,92	83,3/86,5	6,4/7,5	2,3/2,1	2,3/2,4	0,10	215
8,5/33	V. GM 200 L 4/2b	1470/2950	16/59	55/107	0,87/0,9	86,2/88,5	6,8/7,6	2,1/1,9	2,2/2,1	0,13	235
10/40	V. GM 225 M 4/2	1470/2955	20/72	65/129	0,82/0,91	86,3/86,5	5,5/6,5	2/1,8	2/2,4	0,19	315
12,5/48	V. GM 250 M 4/2	1480/2965	25/86	81/155	0,81/0,9	87,3/88,5	5,7/7,5	2,0/2,1	2/2,4	0,32	385
17/66	V. GM 280 S 4/2	1480/2970	33/115	110/212	0,83/0,91	88,3/89,6	6,2/7,9	2,0/2,1	2,2/2,6	0,5	560
20/78	V. GM 280 M 4/2	1480/2970	38/133	129/251	0,84/0,93	88,4/89,6	6,7/8,2	2,0/2,1	2,3/2,7	0,62	595
25/100	V. GM 315 S 4/2	1485/2975	48/172	161/321	0,84/0,92	88,4/89,7	6,5/7,9	1,4/1,7	2,4/2,7	0,96	720
30/120	V. GM 315 M 4/2a	1490/2980	58/205	192/385	0,82/0,92	89,4/90,7	8,0/8,8	1,6/1,9	2,6/2,9	1,2	805
37/150	V. GM 315 M 4/2b	1490/2980	68/252	237/481	0,84/0,92	91,4/91,7	6,5/8,2	1,6/1,9	2,5/2,8	1,4	870
45/175	V. GMM 315 L 4/2	1490/2980	83/295	288/561	0,84/0,92	91,5/91,7	6,7/8,2	1,6/1,9	2,5/2,8	1,42	920

! In variable torque applications, double speed motors must be started first at low speed depending on the start-up current characteristic. They can be switched to high speed after reaching the rated speed.

! In variable torque applications, Dahlander coupled motors are started only directly.

Efficiency values are calculated by the indirect measurement method in accordance with the IEC 60034-2-1: 2014 standard. Additional losses are assessed based on test results performed at variable load values.

standard series- three phase motors

DOUBLE SPEED MOTORS

OPERATIONAL CHARACTERISTICS

3 Phase, 400 V, 50 Hz | Type of Operation: S1 (Continuous Operation)

Protection Degree: IP 55 | Insulation Class: H (180°C) | Heat Increase Limit: B (80K)

ALUMINUM FRAME

8/4 poles - 750/1500 RPM

Load Torque Proportional to the Square of the Speed (Pump and Ventilator) Single Winding - Dahlander Connection Y/YY

Nominal Power kW	Type	At Nominal Power					At Start-up		Tilting Moment Ratio M _k / M _N	Moment of Inertia J kgm ²	Approx. Weight B3 kg
		Speed	Current I _N	Torque M _N	Power Coefficient Cos φ	Efficiency η %	Current Ratio I _A / I _N	Torque Ratio M _A / M _N			
		RPM	A	Nm		IEC 60034-2-1:2007	Direct	Direct			
0,05/0,25	V. AGM 71 8/4a	680/1400	0,28/0,73	0,7/1,7	0,6/0,78	41,7/61,3	2/3,1	1,4/1,3	1,8/1,8	0,00040	4,9
0,065/0,33	V. AGM 71 8/4b	680/1400	0,36/1	0,9/2,3	0,58/0,76	43,6/61,3	2/3,2	1,4/1,4	1,8/1,9	0,00054	5,9
0,12/0,5	V. AGM 80 8/4a	680/1430	0,65/1,5	1,7/3,3	0,51/0,75	50,5/62,3	2,1/3,2	1,4/1,7	1,7/2,1	0,00083	7,6
0,18/0,75	V. AGM 80 8/4b	680/1405	0,90/2	2,5/5,1	0,54/0,81	51,5/65,3	2,1/3,5	1,6/1,7	1,8/2,1	0,0011	8,7
0,25/1	V. AGM 90 S 8/4	700/1410	1,2/2,8	3,4/6,8	0,51/0,69	57,4/73,2	2,7/4,6	1,6/2,1	2,1/2,4	0,0019	11,5
0,33/1,4	V. AGM 90 L 8/4	690/1390	1,3/3,3	4,6/9,6	0,60/0,79	59,4/76,2	2,6/4,3	1,7/1,8	1,9/2,1	0,0024	13,6
0,5/2	V. AGM 100 L 8/4a	700/1415	1,8/4,8	7/13	0,61/0,82	64,3/71,3	2,9/4,8	1,5/1,8	2,1/2,3	0,0038	17,3
0,6/2,5	V. AGM 100 L 8/4b	690/1410	2/5,5	8/17	0,66/0,86	64,3/74,3	3,2/5,2	1,5/1,9	2/2,3	0,0050	20,8
1/3,8	V. AGM 112 M 8/4	700/1425	3,2/8,3	14/25	0,63/0,83	70,2/78,3	3,4/5,2	1,4/2,0	2/2,5	0,0092	28,7
1,2/5	V. AGM 132 S 8/4	715/1450	3,8/10,5	16/33	0,60/0,84	74,2/80,3	3,7/5,4	2,1/2,2	2,4/2,6	0,019	39
1,7/7	V. AGM 132 M 8/4	710/1450	5,2/14,5	23/46	0,66/0,84	69,3/81,3	4/6,6	2,0/2,2	2,2/2,5	0,026	47
2,5/10	V. AGM 160 M 8/4	720/1460	7,4/20	33/65	0,64/0,87	74,3/81,4	3,7/6,4	1,8/2,3	2,2/3	0,054	74
3,5/14	V. AGM 160 L 8/4	720/1460	10,5/28	46/92	0,6/0,83	78,3/85,4	3,7/6,8	1,8/2	2/2,5	0,072	104
4/16	V. AGM 180 M 8/4	720/1465	11,4/32	53/104	0,63/0,82	79,3/86,4	3,8/6	1,8/2,3	1,8/2,4	0,11	128
5/20	V. AGM 180 L 8/4	720/1465	14/40	66/130	0,62/0,81	81,3/87,4	3,9/6,7	1,9/2,5	1,9/2,7	0,13	143
7/28	V. AGM 200 L 8/4	725/1465	16/51	92/183	0,73/0,88	84,2/88,4	4,5/6,6	1,9/2,1	1,9/2,4	0,19	185

CAST IRON FRAME

8/4 poles - 750/1500 RPM

1,2/5	V. GM 132 S 8/4	715/1450	3,8/10,5	16/33	0,6/0,84	74,2/80,3	3,7/5,4	2,1/2,2	2,4/2,6	0,019	51
1,7/7	V. GM 132 M 8/4	710/1450	5,2/14,5	23/46	0,66/0,84	69,3/81,3	4/6,6	2/2,2	2,2/2,5	0,026	60
2,5/10	V. GM 160 M 8/4	720/1460	7,4/20	33/65	0,64/0,87	74,3/81,4	3,7/6,4	1,8/2,3	2,2/3	0,054	105
3,5/14	V. GM 160 L 8/4	720/1460	10,5/28	46/92	0,6/0,83	78,3/85,4	3,7/6,8	1,8/2	2/2,5	0,072	140
4/16	V. GM 180 M 8/4	720/1465	11,4/32	53/104	0,63/0,82	79,3/86,4	3,8/6	1,8/2,3	1,8/2,4	0,11	150
5/20	V. GM 180 L 8/4	720/1465	14/40	66/130	0,62/0,81	81,3/87,4	3,9/6,7	1,9/2,5	1,9/2,7	0,13	170
7/28	V. GM 200 L 8/4	725/1465	16/51	92/183	0,73/0,88	84,2/88,4	4,5/6,6	1,9/2,1	1,9/2,4	0,19	235
8/32	V. GM 225 S 8/4	730/1470	20/60	105/208	0,67/0,86	84,3/88,5	4,3/6,6	2/2,3	2,1/2,7	0,29	275
10/40	V. GM 225 M 8/4	725/1470	26/71	132/260	0,65/0,92	83,3/86,5	4/6,3	1,8/2,3	1,8/2,4	0,35	320
12,5/48	V. GM 250 M 8/4	735/1475	30/87	162/311	0,7/0,88	84,4/89,5	4,3/7,1	2/2,5	1,9/2,9	0,54	395
16,5/63	V. GM 280 S 8/4	730/1475	38/115	216/408	0,70/0,88	87,3/88,6	3,8/6,3	1,6/2,2	1,8/2,4	0,9	550
21/83	V. GM 280 M 8/4	735/1475	50/149	273/537	0,67/0,87	88,4/90,6	3,9/6,9	1,6/2,3	1,8/2,5	1,1	615
25/100	V. GM 315 S 8/4	740/1485	53/174	323/643	0,74/0,89	90,4/91,6	4,7/6,9	1,7/2,2	1,8/2,4	1,6	702
30/120	V. GM 315 M 8/4a	740/1480	69/223	387/774	0,68/0,83	90,4/92,6	5,3/8,1	1,8/2,6	2/2,9	2,1	784
33/132	V. GM 315 M 8/4b	740/1485	74/239	426/849	0,7/0,85	90,4/92,7	5,2/8,1	1,8/2,4	2/2,8	2,5	861
40/160	V. GMM 315 L 8/4	740/1485	86/274	516/1029	0,73/0,9	90,5/92,7	5,2/8,1	1,8/2,4	2/2,8	2,3	875

! In variable torque applications, double speed motors must be started first at low speed depending on the start-up current characteristic. They can be switched to high speed after reaching the rated speed.

! In variable torque applications, Dahlander coupled motors are started only directly.

Efficiency values are calculated by the indirect measurement method in accordance with the IEC 60034-2-1: 2014 standard. Additional losses are assessed based on test results performed at variable load values.

standard series- three phase motors

DOUBLE SPEED MOTORS

OPERATIONAL CHARACTERISTICS

3 Phase, 400 V, 50 Hz | Type of Operation: S1 (Continuous Operation)

Protection Degree: IP 55 | Insulation Class: H (155°C) | Heat Increase Limit: B (80K)

ALUMINUM FRAME

6/4 poles - 1000/1500 RPM

Load torque proportional to the square of the speed (Pump and Ventilator) - two different winding

Nominal Power kW	Type	At Nominal Power					At Start-up		Tilting Moment Ratio M _k / M _N	Moment of Inertia J kgm ²	Approx. Weight B3 kg
		Speed	Current I _N	Torque M _N	Power Coefficient Cos φ	Efficiency η %	Current Ratio I _A / I _N	Torque Ratio M _A / M _N			
		RPM	A	Nm		IEC 60034-2-1:2007	Direct	Direct			
0,05/0,18	V. AGM 71 6/4a	940/1340	0,34/0,72	0,51/1,28	0,42/0,56	48,5/63,2	2/2,1	1,4/1,3	1,9/1,6	0,00064	5,4
0,08/0,24	V. AGM 71 6/4b	940/1350	0,4/0,9	0,81/1,7	0,58/0,65	48,5/60,3	2,3/2,5	1,5/1,4	1,9/1,6	0,00086	6,3
0,15/0,45	V. AGM 80 6/4a	930/1370	0,54/1,3	1,54/3,14	0,77/0,81	50,5/60,4	3,2/3,2	1,7/1,4	2,1/1,5	0,0017	8,1
0,2/0,6	V. AGM 80 6/4b	960/1400	0,74/1,52	2,03/4,09	0,67/0,8	56,4/69,2	3,7/3,8	2,1/1,6	2,7/2	0,0022	9,5
0,3/0,9	V. AGM 90 S 6/4	940/1410	1,1/2,3	3,05/6,1	0,70/0,78	54,5/70,2	2,9/4,3	1,3/1,9	1,9/2,1	0,0019	11,5
0,37/1,1	V. AGM 90 L 6/4	935/1390	1,2/2,8	3,8/7,6	0,71/0,78	61,3/71,2	3,2/4	1,6/1,6	2/2,1	0,0024	13,6
0,6/1,6	V. AGM 100 L 6/4a	950/1420	1,85/4,1	6/10,8	0,73/0,79	62,4/69,3	3,6/5,2	1,6/2,1	2,2/2,3	0,0040	17,3
0,75/2,2	V. AGM 100 L 6/4b	950/1430	2,5/5,3	7,5/14,7	0,68/0,8	62,4/73,3	3,6/4,7	1,7/1,7	2,2/2,3	0,0052	20,8
1,17/3,3	V. AGM 112 M 6/4	955/1440	3,1/7,3	11/21,9	0,70/0,81	71,2/79,2	5/5,8	1,9/2,1	2,9/2,7	0,0092	28,7
1,5/4,5	V. AGM 132 S 6/4	940/1440	4,2/9,5	15,2/29,8	0,75/0,84	67,4/79,3	4,1/5,5	1,7/1,8	2,1/2	0,019	39
2/6,2	V. AGM 132 M 6/4	940/1440	5,2/13,3	20,3/41,1	0,77/0,86	70,3/76,4	4/5,2	1,7/2	1,9/2,2	0,026	47
3/9	V. AGM 160 M 6/4	945/1455	7/18	30,3/59,1	0,78/0,84	77,3/84,3	4,6/6	1,8/2	1,9/2,3	0,054	74
4/13	V. AGM 160 L 6/4	970/1455	9,5/26	39,4/85,3	0,75/0,84	79,3/84,4	4/5,5	1,9/2,1	1,9/2,2	0,072	104
5/15	V. AGM 180 M 6/4	970/1460	11,7/29	49/98	0,74/0,85	81,3/86,3	4,4/5,9	1,8/2,2	1,9/2,2	0,11	128
6/18,5	V. AGM 180 L 6/4	975/1455	14/36	59/121	0,75/0,85	80,3/85,4	5,4/5,5	2,4/2,1	2,5/2,3	0,13	143
7,5/25	V. AGM 200 L 6/4	980/1465	16,6/48	73/163	0,79/0,86	81,3/85,5	6/6,6	2,2/2,2	2,9/2,8	0,19	185
9/30	V. C.AGM 200 L 6/4	980/1470	19/51	88/195	0,78/0,94	86,3/88,4	6,7/7	2,6/2,3	2,9/2,5	0,23	205

CAST IRON FRAME

6/4 poles - 1000/1500 RPM

1,5/4,5	V. GM 132 S 6/4	940/1440	4,2/9,5	15,2/29,8	0,75/0,84	67,4/79,3	4,1/5,5	1,7/1,8	2,1/2	0,019	51
2/5,2	V. GM 132 M 6/4	940/1440	5,2/13,3	20,3/41,1	0,77/0,86	70,3/76,4	4/5,2	1,7/2	1,9/2,2	0,026	60
3/9	V. GM 160 M 6/4	945/1455	7/18	30,3/59,1	0,78/0,84	77,3/84,3	4,6/6	1,8/2	1,9/2,3	0,054	105
4/13	V. GM 160 L 6/4	970/1455	9,5/26	39,4/85,3	0,75/0,84	79,3/84,4	4,0/5,5	1,9/2,1	1,9/2,2	0,072	140
5/15	V. GM 180 M 6/4	970/1460	11,7/29	49,2/98,1	0,74/0,85	81,3/86,3	4,4/5,9	1,8/2,2	1,9/2,2	0,11	150
6/18,5	V. GM 180 L 6/4	975/1455	14/36	58,8/121,4	0,75/0,85	80,3/85,4	5,4/5,5	2,4/2,1	2,5/2,3	0,13	170
7,5/25	V. GM 200 L 6/4	980/1465	16,6/48	73/163	0,79/0,86	81,3/85,5	6,0/6,6	2,2/2,2	2,9/2,8	0,19	235
9/30	V. C.GM 200 L 6/4	940/1470	19/54	88/195	0,78/0,89	86,3/88,4	6,7/7	2,6/2,3	2,9/2,5	0,23	255
13/33	V. GM 225 S 6/4	980/1470	25/67	107/214	0,73/0,8	85,3/87,5	5,0/6,4	1,8/2,1	2,2/2,8	0,29	275
14/40	V. GM 225 M 6/4	980/1470	30/77	136/260	0,78/0,83	84,4/88,5	4,7/6,1	1,8/2	2,3/3	0,35	320
17/50	V. GM 250 M 6/4	980/1475	36/92	166/324	0,8/0,85	83,4/90,5	5,2/7,2	2/2,5	2,4/3,1	0,54	395
22/65	V. GM 280 S 6/4	985/1480	46/116	213/419	0,78/0,91	87,4/87,6	6,6/5,4	2,3/1,7	2,3/1,8	0,90	550
26/75	V. GM 280 M 6/4	990/1480	56/137	251/484	0,75/0,89	87,4/87,6	6,8/5,5	2,5/1,6	2,5/1,7	1,1	615
32/95	V. GM 315 S 6/4	990/1480	63/164	309/613	0,81/0,9	89,4/91,6	6,7/6	2,2/1,7	2,5/2,2	1,6	702
37/115	V. GM 315 M 6/4a	990/1485	74/200	357/740	0,79/0,88	89,5/92,6	8/7	2,5/1,8	2,9/2,6	2,1	784
45/132	V. GM 315 M 6/4b	990/1485	91/223	434/849	0,78/0,91	90,5/92,7	8/6,5	2,5/1,8	2,9/2,5	2,5	861
50/150	V. GMM 315 L 6/4	990/1485	98/257	482/965	0,8/0,9	90,5/92,7	7/6,2	2,2/1,7	2,6/2,3	2,3	875

! In variable torque applications, double speed motors must be started first at low speed depending on the start-up current characteristic. They can be switched to high speed after reaching the rated speed.

! In variable torque applications, Dahlander coupled motors are started only directly.

Efficiency values are calculated by the indirect measurement method in accordance with the IEC 60034-2-1: 2014 standard. Additional losses are assessed based on test results performed at variable load values.

Options, Dimensions and Spare Parts

THREE PHASE SQUIRREL CAGE INDUCTION MOTORS

Options	56	63	71	80	90	100	112	132	160	180	200	225	250	280	315	355	400	450
1 Order of Installation																		
B5, V1 (Aluminum)	O	O	O	O	O	O	O	O	N/A	N/A	N/A	N/A	N/A	N/A	N/A	N/A	N/A	N/A
B5 Cast Iron	N/A	N/A	N/A	N/A	N/A	N/A	N/A	O	O	O	O	O	O	O	O	O	O	R
B14 / B14-2	O	O	O	O	O	O	O	O	N/A	N/A	N/A	N/A	N/A	N/A	N/A	N/A	N/A	N/A
B14 / B14-2 - Cast Iron	N/A	N/A	N/A	N/A	N/A	N/A	N/A	48.0	78.0	N/A	N/A	N/A	N/A	N/A	N/A	N/A	N/A	N/A
2 Special Winding																		
	O	O	O	O	O	O	O	O	O	O	O	O	O	O	O	O	O	R
3 Special Shaft																		
According to Drawing	R	R	R	R	R	R	R	R	R	R	R	R	R	R	R	R	R	R
Rear Shaft Outlet	O	O	O	O	O	O	O	O	O	O	O	O	O	O	O	O	O	R
4 IP 56																		
	O	O	O	O	O	O	O	O	O	O	O	O	O	O	O	O	O	R
5 Roller Bearing (NU) - 2 P*																		
	N/A	N/A	N/A	N/A	N/A	N/A	N/A	O	O	O	O	O	O	O	O	O	O	R
5 Roller Bearing (NU) - 4 6 8 P*																		
	N/A	N/A	N/A	N/A	N/A	N/A	N/A	N/A	N/A	N/A	N/A	N/A	N/A	N/A	N/A	N/A	N/A	R
6 H Insulation																		
	O	O	O	O	O	O	O	O	O	O	O	O	O	O	S	S	S	S
7 Forced Cooling																		
	N/A	N/A	O	O	O	O	O	O	O	O	O	O	O	O	O	O	O	R
8 Heater - 1AC 230 V - 1 AC 110 V																		
	O	O	O	O	O	O	O	O	O	O	O	O	O	O	O	O	O	R
9 Canopy																		
	N/A	O	O	O	O	O	O	O	O	O	O	O	O	O	O	O	R	R
10 Motor Protection																		
1x PTC	R	R	R	R	R	R	R	R	R	R	R	R	R	R	R	R	R	R
2x PTC	R	R	R	R	R	R	R	R	R	R	R	R	R	R	R	R	R	R
3x PTC	O	O	O	O	O	O	O	O	S	S	S	S	S	S	S	S	S	
3x NC Thermostat	R	R	R	R	R	R	R	R	R	R	R	R	R	R	R	R	R	R
3x PT 100 - At winding	O	O	O	O	O	O	O	O	O	O	O	O	O	O	O	O	O	O
2x PT100 - At Bearings	R	R	R	R	R	R	R	R	O	O	O	O	O	O	O	O	O	O
11 Lubricable Cover																		
	N/A	N/A	N/A	N/A	N/A	N/A	N/A	O	O	O	O	O	O	O	S	S	S	S
12 Insulated Rear Cover																		
	N/A	N/A	N/A	N/A	N/A	N/A	N/A	N/A	N/A	N/A	N/A	N/A	O	O	O	O	O	O
13 Insulated Bearing																		
	R	R	R	R	R	R	R	R	R	R	R	R	R	R	R	R	R	R
14 Same-bearing																		
	N/A	N/A	N/A	N/A	N/A	N/A	N/A	N/A	O	O	O	O	O	S	S	S	S	S
15 Metal Terminal Box																		
	N/A	N/A	O	O	O	O	O	O	O	O	S	S	S	S	S	S	S	S
16 Water Drain Holes																		
	R	R	R	R	R	R	R	R	R	R	R	R	R	R	R	R	R	R
17 Oil Seal																		
	S	S	S	S	S	S	S	S	S	S	S	S	S	S	S	S	S	S
18 Vibration Monitoring Point																		
	R	R	R	R	R	R	R	R	R	R	R	R	R	R	R	R	R	R
19 Metal Cable Gland																		
	R	R	R	R	R	R	R	R	R	R	R	R	R	R	R	S	R	R
20 Encoder																		
	R	R	R	R	R	R	R	R	R	R	R	R	R	R	R	R	R	R
21 Tropical Protection																		
	R	R	R	R	R	R	R	R	R	R	R	R	R	R	R	R	R	R
22 Paint - with RAL Code																		
	R	R	R	R	R	R	R	R	R	R	R	R	R	R	R	R	R	R

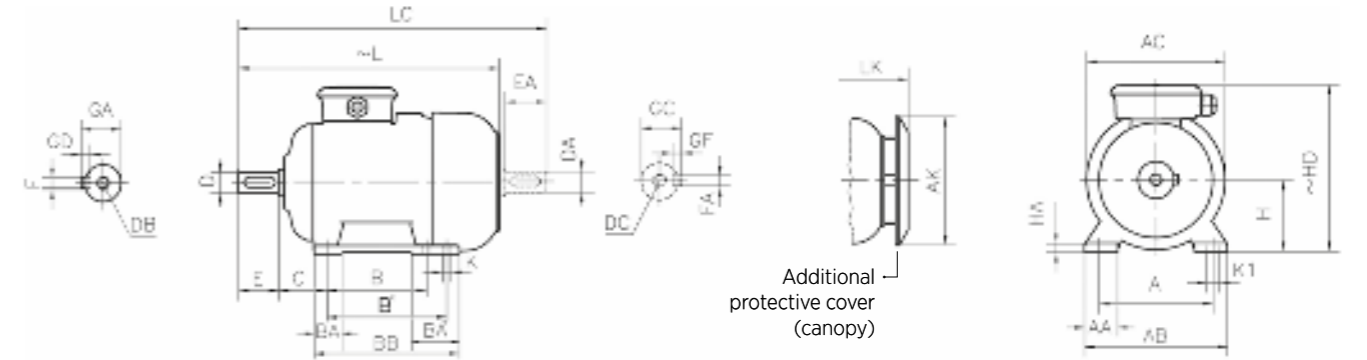

Frame Size	No of Poles	Sizes of foot mounted motor: Frame Forms B3, B6, B7, B8, B15, V5, V6																								
		H	HD	HA	A	AA	AB	ACØ	AKØ	K	K1	B	B'	BA	BA	BB	L	LC	LK	C	E EA	DB' DC	DØ DAØ	GA GC	FxGD FxGF	
56	M	2-4	56	152	9	90	28	112	105	-	6	9	71	-	24	-	87	161	185	-	36	20	M4	9	10,2	3x3
63	M	2-4	63	160	10	100	31	125	121	116	7	11	80	-	27	-	103	216	243	245	40	23	M4	11	12,5	4x4
71	M	2-4-6-8	71	182	10	112	33	140	138	116	7	11	90	-	27	-	108	249	284	278	45	30	M5	14	16	5x5
80	M	2-4-6-8	80	198	10	125	38	160	156	151	10	15	100	-	33	-	125	279	324	308	50	40	M6	19	21,5	6x6
90	S L	2-4-6-8	90	216	12	140	43	180	176	151	10	15	100	-	35	-	130	309	364	338	56	50	M8	24	27	8x7
100	L H	2-4-6-8 4	100	244	13	160	47	200	194	189	12	18	140	-	39	-	175	376	442	413	63	60	M10	28	31	8x7
112	M S	2-4-6-8 2-4-6-8	112	267	13	190	47	230	218	189	12	18	140	-	39	-	175	396	462	433	70	60	M10	28	31	8x7
132	M H	2-4-6-8 6	132	315	15	216	49	260	257	239	12	18	140	-	46	-	218	498	584	535	89	80	M12	38	41	10x8
160	M L	2-4-6-8 2-4	160	390	21,5	254	60	312	310	303	15	19	210	254	60	104	304	600	716	657	108	110	M16	42	45	12x8
180	M L	2-4-6-8 2-4	180	430	24	279	68	354	348	303	15	19	241	279	56	86	320	657	773	714	121	110	M16	48	51,5	14x9
200	L	2-4-6-8	200	490	26	318	80	398	390	370	19	24	305	-	68	-	355	747	865	803	133	110	M20	55	59	16x10

Note: Some variant codes cannot be used together.

- S Standard features
- O Optional features
- R Please ask
- N/A Not applicable

DB, DC: DIN 332-2 Form D

All dimensions are in mm.

FOOT-MOUNTED (B3) - ALUMINUM FRAME

Options, Dimensions and Spare Parts

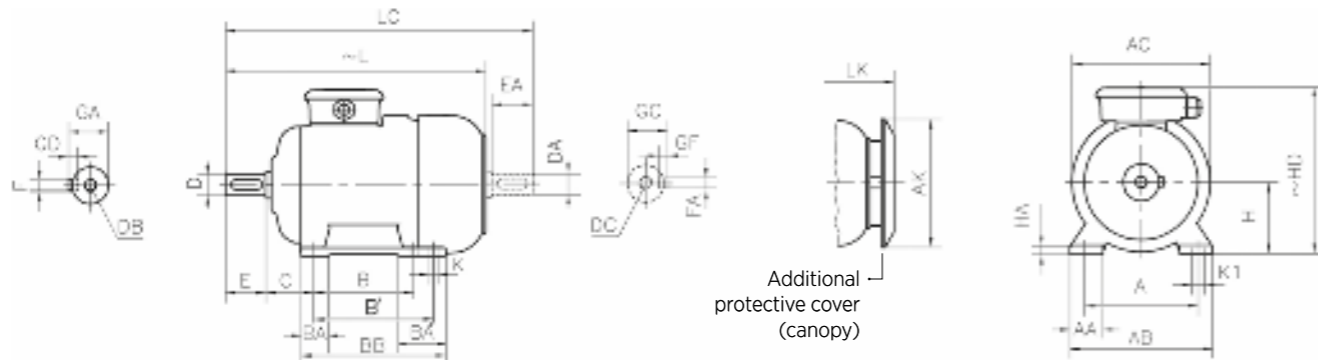

Additional protective cover (canopy)

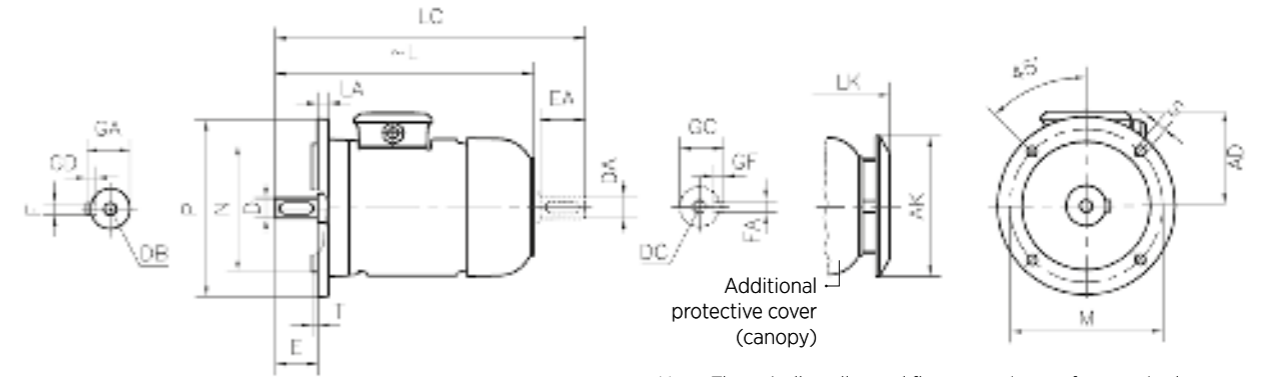

Note: The spindle collar and flange seating surface are in the same plane.

Frame Size	No of Poles	Sizes of foot mounted motor: Frame forms B3, B6 ¹⁾ , B7 ¹⁾ , B8 ¹⁾ , B15, V5 ¹⁾ , V6 ¹⁾																													
		H	HD	HA	A	AA	AB	AC	AK	K	B	B'	BA	BA'	BB	L	LC	LK	C	E EA	DB ²⁾ DC	DØ DAØ	GA GC	FxGD FxGF							
132	$\frac{S}{M}$	2-4-6-8	132	330	15	216	52	260	257	239	12	140	178	46	84	218	498	584	535	89	80	M12	38	41	10x8						
160	$\frac{M}{L}$	2-4-6-8	160	400	22	254	60	312	310	303	15	210	-	62	-	260	600	716	657	108	110	M16	42	45	12x8						
180	$\frac{M}{L}$	2-4-6-8	180	440	24	279	68	354	348	303	15	241	279	57	85	319	660	773	714	121	110	M16	48	51,5	14x9						
200	L	2-4-6-8	200	490	26	318	80	398	390	370	19	305	-	68	-	355	747	865	803	133	110	M20	55	59	16x10						
225	S	4-8	225	520	30	356	82	438	434	370	19	286	311	76	92,5	363	795	943	851	140	M20	60	64	18x11							
	M	2										311	-												371	790	908	846	149	110	55
250	M	2	250	580	35	406	80	484	480	440	24	349	-	75	-	410	896	1044	952	168	140	M20	60	64	18x11						
	S	4-6-8																								311	-	371	820	968	876
280	M	2	280	640	40	457	120	550	544	440	24	368	419	85	128	474	958	1106	1014	190	140	M20	65	69	18x11						
	S	4-6-8																								311	-	371	820	968	876
315	M	2	315	825	50	508	125	620	614	571	28	508	-	125	-	600	1120	1270	1197	216	M20	65	69	18x11							
	S	4-6-8																							1150	1330	1227	170	85	90	22x14
	M	2																							1120	1270	1197	140	65	69	18x11
	L	4-6-8																							1150	1330	1227	170	85	90	22x14
355	M	2	355	980	50	610	150	740	732	571	28	508	-	125	-	600	1220	1400	1297	254	M20	65	69	18x11							
	S	4-6-8																							1300	1450	1377	170	85	90	22x14
	M	2																							1330	1510	1414	170	85	90	22x14
	L	4-6-8																							1377	1597	1454	210	100	106	28x16
400	L	2	400	1100	50	686	165	860	850	704	35	800	-	170	-	934	1670	1840	1750	280	M20	80	85	22x14							
	M	4-6-8																							1710	1920	1790	210	110	116	28x16
450	L	2	450	1201	62	800	180	975	960	704	45	900	-	200	-	1050	1768	1948	1845	280	M24	90	95	25x14							
	M	4-6-8																							1808	2028	1885	210	120	127	32x18
450	H	2	450	1283	62	800	180	975	960	704	45	1250	-	300	-	1450	2268	2448	2345	280	M24	90	95	25x14							
	M	4-6-8																							2308	2528	2385	210	120	127	32x18

1) Up to frame sizes B6, B7, B8, V5 and V6 315 M.
2) DB, DC: DIN 332-2 Form D

All dimensions are in mm.

FOOT-MOUNTED (B3) - ALUMINUM FRAME

Frame Size	No of Poles	Sizes of motor with flange: (Flange form A - DIN EN 50 347), B5, V1, V3 frame forms																			
		Flange Nr.	MØ	NØ	PØ	Fixing Hole No.	SØ	T	LA	AD	AKØ	L	LC	LK	E EA	DB ²⁾ DC	DØ DAØ	GA GC	FxGD FxGF		
56	M	2-4	FF100	100	80	120	4	7	3	8	96	-	161	185	-	20	M4	9	10.2	3x3	
63	M	2-4	FF115	115	95	140	4	10	3	10	97	116	216	243	245	23	M4	11	12.5	4x4	
71	M	2-4-6-8	FF 130	130	110	160	4	10	3.5	10	110	116	249	284	278	30	M5	14	16	5x5	
80	M	2-4-6-8	FF 165	165	130	200	4	12	3.5	12	118	151	279	324	308	40	M6	19	21.5	6x6	
90	$\frac{S}{L}$	2-4-6-8	FF 165	165	130	200	4	12	3.5	12	126	151	309	364	338	50	M8	24	27	8x7	
	334												389	363							
100	$\frac{L}{H}$	2-4-6-8	FF 215	215	180	250	4	14.5	4	15	144	189	376	442	413	60	M10	28	31	8x7	
	406												472	443							
112	M	2-4-6-8	FF 215	215	180	250	4	14.5	4	15	156	189	396	462	433	60	M10	28	31	8x7	
132	$\frac{S}{M}$	2-4-6-8	FF 265	265	230	300	4	14.5	4	20	183	239	460	546	497	80	M12	38	41	10x8	
	498												584	535							
160	$\frac{M}{L}$	2-4-6-8	FF300	300	250	350	4	18.5	5	20	235	303	600	716	657	110	M16	42	45	12x8	
	644												760	701							
180	$\frac{M}{L}$	2-4-6-8	FF300	300	250	350	4	18.5	5	20	250	303	660	773	714	110	M16	48	51.5	14x9	
200	L	2-4-6-8	FF350	350	300	400	4	18.5	5	20	288	370	747	865	803	110	M20	55	59	16x10	

DB, DC: DIN 332-2 Form D

All dimensions are in mm.

FOOT-MOUNTED (B3) - ALUMINUM FRAME

Options, Dimentions and Spare Parts

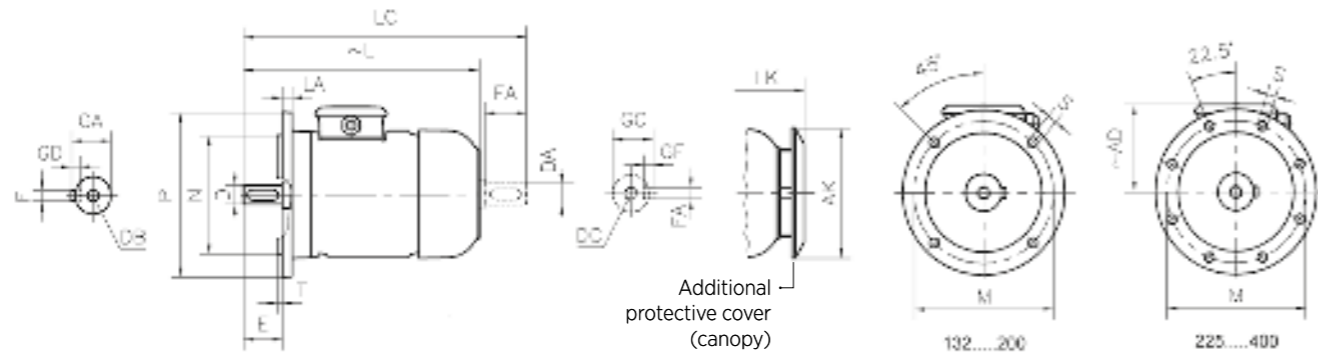

Additional protective cover (canopy)

Note: The spindle collar and flange seating surface are in the same plane.

Frame Size	No of Poles	Sizes of motor with flange: (Flange Form A - DIN EN 50 347) B5 ¹⁾ , V1, V3 ²⁾ frame forms																		
		Flange Nr.	MØ	NØ	PØ	Fixing Hole No.	SØ	T	LA	AD	AKØ	L	LC	LK	E	EA	DB ²⁾ DC	DØ DAØ	GA GC	FxGD FxGF
132	$\frac{S}{M}$	2-4-6-8	FF 265	265	230	300	4	14,5	4	20	198	239	498	584	535	80	M12	38	41	10x8
160	$\frac{M}{L}$	2-4-6-8	FF 300	300	250	350	4	18,5	5	20	245	303	600	716	657	110	M16	42	45	12x8
													644	760	701					
180	$\frac{M}{L}$	2-4-6-8	FF 300	300	250	350	4	18,5	5	20	260	303	660	773	714	110	M16	48	51,5	14x9
200	L	2-4-6-8	FF 350	350	300	400	4	18,5	5	20	288	370	747	865	803	110	M20	55	59	16x10
225	S	4-8	FF 400	400	350	450	8	18,5	5	20	295	370	795	943	851	140	M20	60	64	18x11
	M	2											790	908	846	110		55	59	16x10
		4-6-8											820	968	876	140		60	64	18x11
250	M	2	FF 500	500	450	550	8	18,5	5	24	330	440	896	1044	952	140	M20	60	64	18x11
		4-6-8											65	69	18x11					
280	S	2	FF 500	500	450	550	8	18,5	5	24	360	440	958	1106	1014	140	M20	75	79,5	20x12
													4-6-8	65	69	18x11				
													4-6-8	75	79,5	20x12				
315	S	2	FF 600	600	550	660	8	24	6	24	510	571	1120	1270	1197	140	M20	65	69	18x11
													1150	1330	1227	170		85	90	22x14
													1120	1270	1197	140		65	69	18x11
													1150	1330	1227	170		85	90	22x14
	M	4-6-8											1190	1340	1267	140		65	69	18x11
													1220	1400	1297	170		85	90	22x14
													1300	1450	1377	140		65	69	18x11
													1330	1510	1407	170		85	90	22x14
L	4-6-8	1337	1517	1414	170	M20	80	85	22x14											
		1337	1597	1454	210	M24	100	106	28x16											
		1467	1647	1544	170	M20	80	85	22x14											
		1507	1727	1584	210	M24	100	106	28x16											
400	L	2	FF 940 ³⁾	940	880	1000	8	28	6	32	700	704	1670	1840	1750	170	M20	80	85	22x14
													1710	1820	1677	210		M24	110	116
450	L	2	FF 1080 ³⁾	1080	1000	1150	8	28	6	32	751	704	1768	1948	1845	170	M24	90	95	25x14
													1808	2028	1885	210		120	127	32x18

1) Up to frame sizes B6, B7, B8, V5 and V6 315 M
2) DB, DC: DIN 332-2 Form D

All dimensions are in mm.

FOOT-MOUNTED AND FLANGED (FORM C-B35) - ALUMINUM FRAME

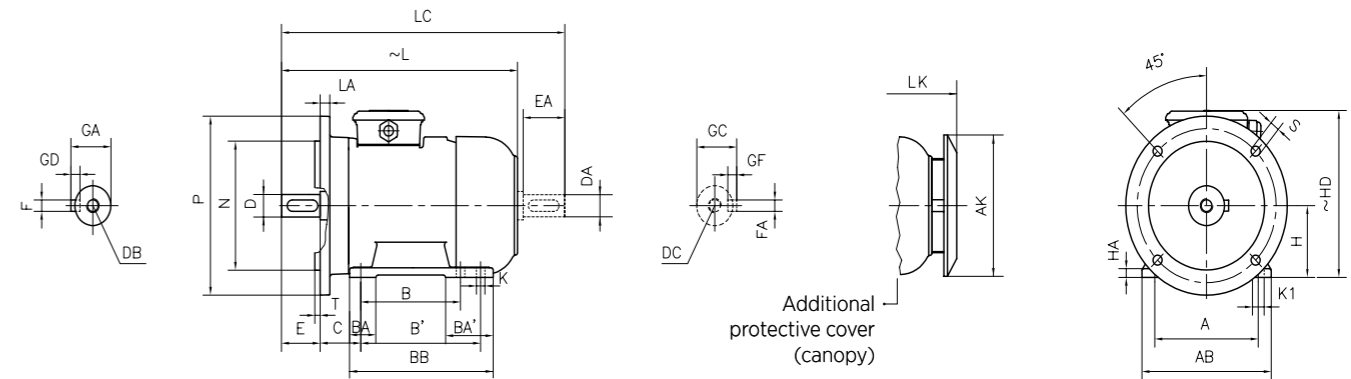

Additional protective cover (canopy)

Note: The spindle collar and flange seating surface are in the same plane.

Frame Size	No of Poles	Sizes of motors Foot-Mounted and flange: (Flange form A - DIN EN 50 347), B35 frame forms																														
		H	HD	HA	A	AB	AKØ	K	K1	B	B'	BA	BA'	BB	Flans No.	MØ	NØ	PØ	No	SØ	T	LA	L	LC	LK	C	E	EA	DB ¹⁾ DC	DØ DAØ	GA GC	FxGD FxGF
56	M	2-4	56	152	9	90	112	-	5,8	9	71	-	24	-	87	FF100	100	80	120	4	7	3	8	161	185	-	36	20	M4	9	10,2	3x3
63	M	2-4	63	160	10	100	125	116	7	11	80	-	27	-	103	FF115	115	95	140	4	10	3	10	216	243	245	40	23	M4	11	12,5	4x4
71	M	2-4-6-8	71	182	10	112	140	116	7	11	90	-	27	-	108	FF130	130	110	160	4	10	3,5	10	249	284	278	45	30	M5	14	16	5x5
80	M	2-4-6-8	80	198	10	125	160	151	10	15	100	-	33	-	125	FF165	165	130	200	4	12	3,5	12	279	324	308	50	40	M6	19	21,5	6x6
90	S	2-4-6-8	90	216	12	140	180	151	10	15	100	-	35	-	130	FF165	165	130	200	4	12	3,5	12	309	364	338	56	50	M8	24	27	8x7
																								334	389	363						
100	L	2-4-6-8	100	244	13	160	200	189	12	18	140	-	39	-	175	FF215	215	180	250	4	14,5	4	15	376	442	413	63	60	M10	28	31	8x7
																								406	472	443						
112	M	2-4-6-8	112	267	13	190	230	189	12	18	140	-	39	-	175	FF215	215	180	250	4	14,5	4	15	396	462	433	70	60	M10	28	31	8x7
132	S	2-4-6-8	132	315	15	216	260	239	12	18	140	-	46	-	180	FF265	265	230	300	4	14,5	4	20	460	546	497	89	80	M12	38	41	10x8
																								498	584	535						
																								523	614	560						
160	M	2-4-6-8	160	390	22	254	312	303	15	19	210	254	60	104	304	FF300	300	250	350	4	18,5	5	20	600	716	657	108	110	M16	42	45	12x8
																								644	760	701						
180	M	2-4-6-8	180	430	24	279	354	303	15	19	241	279	56	86	320	FF300	300	250	350	4	18,5	5	20	660	773	714	121	110	M16	48	51,5	14x9
																								747	865	803						
200	L	2-4-6-8	200	490	26	318	398	370	19	24	305	-	68	-	355	FF350	350	300	400	4	18,5	5	20	747	865	803	133	110	M20	55	59	16x10

1) DB, DC: DIN 332-2 Form D

All dimensions are in mm.

Options, Dimentions and Spare Parts

Three Phase Motors

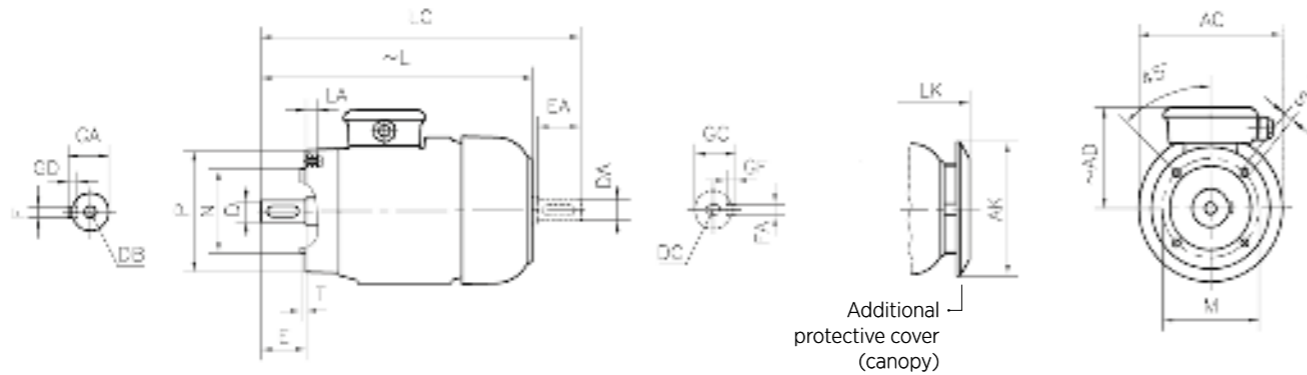

Note: The spindle collar and flange seating surface are in the same plane.

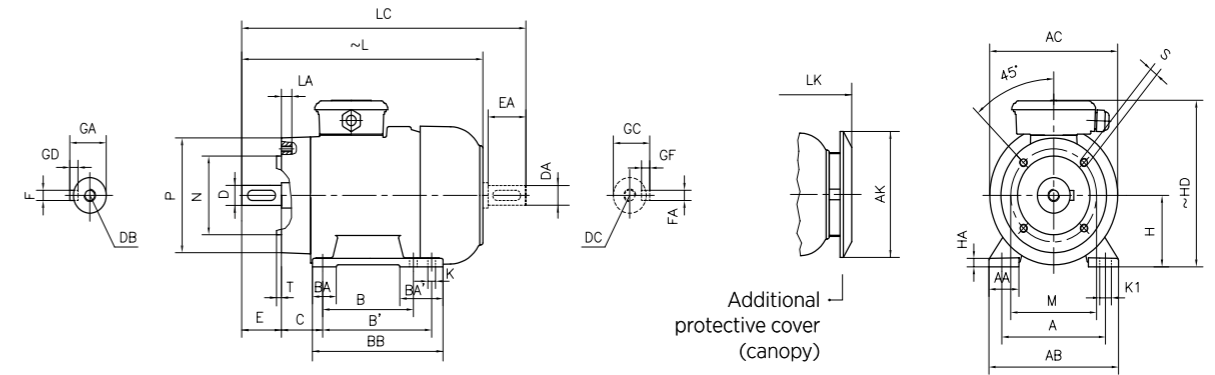

Note: The spindle collar and flange seating surface are in the same plane.

Frame Size	No of Poles	Sizes of motor with flange: (Flange C - DIN EN 50 347), B14, V18, V19 frame forms																	
		Flange Nr.	MØ	NØ	PØ	S	T	LA ⁴⁾	ACØ	AKØ	AD	L	LC	LK	E EA	DB ¹⁾ DC	DØ DAØ	GA GC	FxGD FxGF
132	S	FT 165	165	130	200	M10	3,5	18	257	239	198	498	584	535	80	M12	38	41	10x8
	M	FT 215	215	180	250	M12	4												
	S	FT 165	165	130	200	M10	3,5												
160	M	FT 215	215	180	250	M12	4	21	310	303	245	600	716	657	110	M16	42	45	12x8
	L	FT 215	215	180	250	M12	4					644	760	701					

Frame Size	No of Poles	Sizes of motors Foot-Mounted and flange: (Flange Form C - DIN EN 50 347) B34 Frame Form																															
		H	HD	HA	A	AA	AB	ACØ	AKØ	K	K1	B	B'	BA	BA'	BB	Flans No.	MØ	NØ	PØ	S	T	LA	L	LC	LK	C	E EA	DB ¹⁾ DC	DØ DAØ	GA GC	FxGD FxGF	
56	M	2-4	56	152	9	90	28	112	105	-	5,8	9	71	-	24	-	87	FT165	65	50	80	M5	2,5	10	161	185	-	36	20	M4	9	10,2	3x3
																		FT85	85	70	105	M6	3	12									
63	M	2-4	63	160	10	100	31	125	121	116	7	11	80	-	27	-	103	FT75	75	60	90	M5	2,5	10	216	243	245	40	23	M4	11	12,5	4x4
																		FT100	100	80	120	M6	3	12									
71	M	2-4-6-8	71	182	10	112	33	140	138	116	7	11	90	-	27	-	108	FT85	85	71	105	M6	2,5	12	249	284	278	45	30	M5	14	16	5x5
									-									FT115	115	95	140	M8	3	16									
80	M	2-4-6-8	80	198	10	125	38	160	156	151	10	15	100	-	33	-	125	FT100	100	80	120	M6	3	12	279	324	308	50	40	M6	19	21,5	6x6
									-									FT130	130	110	160	M8	3,5	16									
90	S	2-4-6-8	90	216	12	140	43	180	176	151	10	15	100	-	35	-	130	FT115	115	95	140	M8	3	16	309	364	338	56	50	M8	24	27	8x7
																		3,5	FT130	130	110		160										
100	L	2-4-6-8	90	216	12	140	43	180	176	151	10	15	125	-	-	-	155	FT115	115	95	140	M8	3	16	334	389	363	63	60	M10	28	31	8x7
																		3,5	FT130	130	110		160										
100	H	4	100	244	13	160	47	200	194	189	12	18	140	-	39	-	175	FT130	130	110	160	M8	3,5	16	376	442	413	63	60	M10	28	31	8x7
																		20	FT165	165	130		200										
112	M	2-4-6-8	112	267	13	190	47	230	218	189	12	18	140	-	39	-	175	FT130	130	110	160	M8	3,5	16	396	462	433	70	60	M10	28	31	8x7
																		15	FT165	165	130		200										
132	S	2-4-6-8	132	315	15	216	49	260	257	239	12	18	140	-	46	-	180	FT165	165	130	200	M10	3,5	16	460	546	497	89	80	M12	38	41	10x8
																		4	FT215	215	180		250										
	M	2-4-6-8	6	132	315	15	216	49	260	257	239	12	18	178	-	-	218	FT165	165	130	200	M10	3,5	16	498	584	535	89	80	M12	38	41	10x8
																		18	FT215	215	180		250										
160	M	2-4-6-8	160	390	22	254	60	312	310	303	15	19	210	254	60	104	304	FT215	215	180	250	M12	4	21	600	716	657	108	110	M16	42	45	12x8
																		18	FT215	215	180		250										
160	H	2-4	160	390	22	254	60	312	310	303	15	19	210	254	60	104	304	FT215	215	180	250	M12	4	21	644	760	701	108	110	M16	42	45	12x8
																		18	FT215	215	180		250										

1) DB, DC: DIN 332-2 Form D

All dimensions are in mm.

1) DB, DC: DIN 332-2 Form D

All dimensions are in mm.

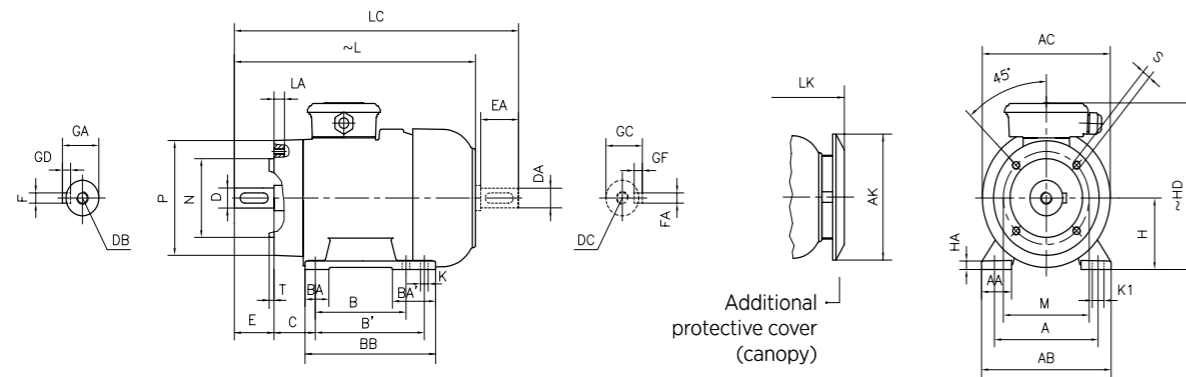

Note: The spindle collar and flange seating surface are in the same plane.

Frame Size	No of Poles	Sizes of motors Foot-Mounted and flange: (Flange form C - DIN EN 50 347) B34 frame forms																																		
		H	HD	HA	A	AA	AB	AC	AK	K	B	B'	BA	BA'	BB	Flans No.	M	N	P	S	T	LA	L	LC	LK	C	E EA	DB ¹⁾ DC	D	DA	GA	GC	FxGD	FxGF		
132	S	2-4-6-8	132	330	15	216	52	260	257	239	12	140	178	46	84	218	FT 165	165	130	200	M10	3,5	16	498	584	535	89	80	M12	38	41	10x8				
																	FT 215	215	180	250	M12	4	18													
	M		2-4-6-8	160	400	22	254	60	312	310	303	15	210	254	-	62	-	260	FT 165	165	130	200	M10	3,5	16	600	716	657	108	110	M16	42	45	12x8		
																			FT 215	215	180	250	M12	4	18											
L	2-4-6-8	160	400	22	254	60	312	310	303	15	210	254	-	62	-	260	FT 215	215	180	250	M12	4	21	644	760	701										

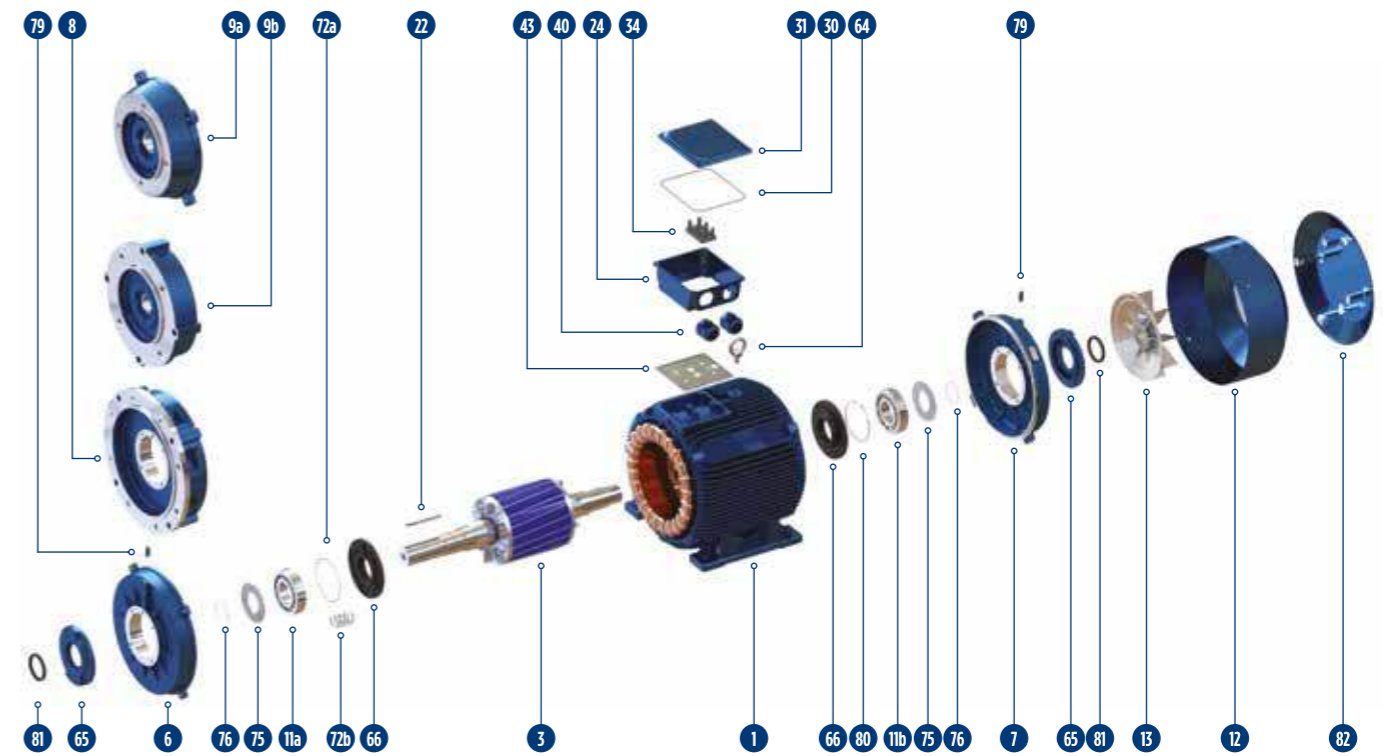

- 1 Stator with complete windings: Varnished and installed to the body
- 3 Complete Rotor: With balanced, shaft, machined (excluding keys), front cover
- 6 Front cover
- 7 Rear cover
- 8 Flange (Form A - "FF") - Flange number must be specified
- 9a Flange (Form C - "FT") - Flange number must be specified
- 9b Flange (Form C - "FT", Large type) - Flange number must be specified
- 11a Front bearing (Ball or Cylindrical Roller)
- 11b Rear bearing
- 12 Fan housing bowl (63...450)
- 13 Cooling fan (63.450)
- 22 Shaft end key
- 24 End terminal box
- 30 Seal (Between terminal box and cover)
- 31 Terminal box cover
- 34 End plate - Terminal (including bridge, nuts and washers)
- 40 Cable entry gland
- 43 Seal (Between end terminal box and motor frame)
- 64 Lifting eye (200..450)
- 65 Bearing holder outer cover (for motors with lubrication nipple)
- 66 Bearing holder inner cover (for motors with lubrication nipple)
- 72a Disc spring (56...280)
- 72b Coil Spring (315..450)
- 75 Oil retaining disc (for motors with lubrication nipple)
- 76 Outer snap ring; For fixing the bearing and oil holding disc
- 79 (For motors with lubrication nipple at the front and rear, 160. 280 at the rear)
- 80 Inner snap ring For fixing the rear bearing on the cover (160..280)
- 81 Rubber dust seal (V-ring) or optional oil seal
- 82 Canopy

1) DB, DC: DIN 332-2 Form D

All dimensions are in mm.

STANDARD
SERIES

”
SINGLE PHASE
MOTORS
“

SINGLE PHASE MOTORS

WITH FLANGE (FORM C-B14) - CAST IRON FRAME

Options, Dimensions and Spare Parts

SINGLE PHASE FULLY ENCLOSED (IP 55) STANDARD ASYNCHRONOUS MOTORS

Single-phase motors comply with the same standards as 3-phase motors in mechanical terms. The rotating field that creates the motor torque in single-phase motors is created with the help of 2 separate windings called the main and auxiliary windings. These motors can be selected with permanent capacitors or start-up + permanent circuit capacitors depending on the application they will be used in. Both types of motors have the following benefits and limitations.

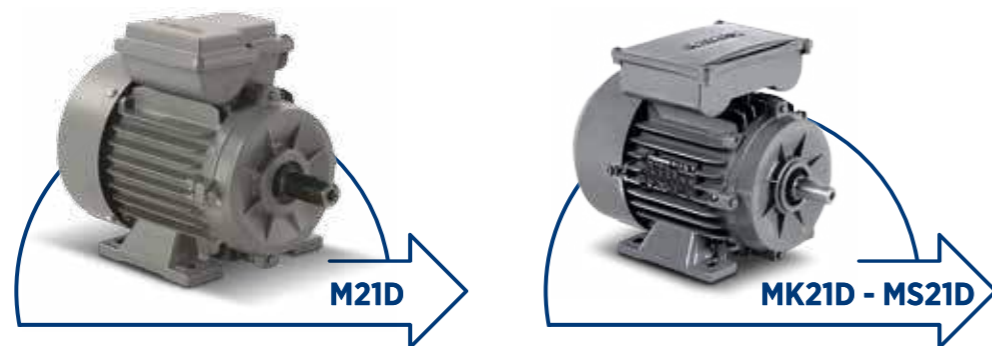

Design with Permanent Circuit Capacitor

At this type of single-phase motors, the permanent circuit capacitor, which is active during operation, is connected in series with the auxiliary winding. Its power coefficient is high. Permanent circuit capacitor motors with a start-up torque between 50-80% of the nominal torque are especially used in applications that do not require high start-up torque, such as circular saws, drill machines, polishers, lawn mowers, pumps and fans.

Start-up + Design with Permanent Circuit Capacitor

In this type of single-phase motors, there is a short-term start-up capacitor and a permanent circuit capacitor placed in the terminal box. An electronic relay and a centrifugal switch are designed in order to deactivate the start-up capacitor. Start-up + Permanent Circuit Capacitor motors are used in applications where high start-up torque is needed, such as compressors, hydraulic pumps and centrifugal pumps, since the starting torque of the motors is between 200-250% of the full load torque.

Electronic Relay

Start-up + Permanent Circuit Capacitor motors' main and auxiliary winding ends and the permanent circuit capacitor and the ends of the starting capacitor connected in parallel to the permanent circuit capacitor are connected to the terminals of the electronic start-up relay and when the voltage is applied to the supply terminals, the motor starts-up to move with a high starting torque.

When the motor reaches approximately 75-80% of the nominal speed, it will have reached sufficient torque to lift the counter load. At that very moment, the motor should not be started-up for it disables the start-up capacitor by controlling the voltage and the motor continues to operate with a single capacitor, just like the permanent capacitor design.

If the motor fails to start within 3 seconds for any reason, the start capacitor is deactivated by way of a safety time integrated circuit added to the electronic start-up relay, thus the start-up capacitor is protected against burning and the auxiliary winding is protected against overloading during the lockout.

More than 3 starts per minute in terms of the resistance of the electrolytic starting circuit capacitor on the auxiliary winding of the electronic start-up relay. Additionally, between two start-ups sufficient time must have passed for the motor shaft to stop.

In order to discharge the voltage formed on the start-up circuit capacitors, the discharge resistors are connected in parallel to the capacitors. Please consult our company for the capacitance and resistance values in case the capacitors need to be changed.

The electronic start-up relay is designed to operate in 220-240V 50/60 Hz single-phase networks and is protected against excessive start-up currents and network harmonics that may occur in different applications. Please consult us about the appropriate relay in case the motor operates with non-standard voltage.

The Centrifugal Switch

It is the key that moves with the centrifugal force generated as a result of the rotational movement of the shaft. While both capacitors are active at the moment of start-up, it deactivates the start-up capacitor.

In applications where single-phase motors are overloaded, since the centrifugal force decreases with the motor speed, the contacts of the centrifugal switch are closed and the starting capacitor is reactivated, and in the electronic start relay, the starting capacitor cannot be re-activated before the motor is de-energized.

Frame, Bearing Carrier Covers and Flanges

Frame Size 71...100: The bodies, covers and flanges of the motors are pressure die-cast from corrosion-resistant aluminum alloy.

Enclosure Degree of Protections

GAMAK motors are manufactured in a fully enclosed structure in accordance with the IP 55 protection degree so that they can work in dusty and humid environments, and on request, they can be manufactured in accordance with IP 56, IP65 and IP66 protection degrees.

Terminal Box

End terminal boxes are suitable for IP 65 protection degree and they are placed on the upper front of the motor so that the supply cable entry can be made easily from both sides. Electronic start-up relay and centrifugal switch, start-up circuit capacitor and permanent circuit capacitor are located in the motor terminal box and the connection types are shown with a diagram on the cover of the connection box.

Shaft End

In our standard production, the shaft end of the motors is single-sided and is fitted with an appropriate wedge (TS 731 / IEC 072-1). In addition, a thread in accordance with DIN 332 shape D is tapped on the shaft end. Upon request, motors can be manufactured with shaft ends on both sides. Shaft end runout, concentricity of flange bill and steepness of surface are within the normal limits given in TS 731 / IEC 60 072-1.

Vibration

The dynamic balance of the rotors of our standard motors is made in accordance with the "normal" mechanical vibration class with the half wedge placed on the shaft end.

Painting

MK21D - MS21D - M21D motors are painted with RAL 7031 (DIN 1843) gray, protective paint; on request, a special exterior paint is applied which is resistant to extremely humid atmosphere, chemicals and micro-organisms.

Storage

If the motors are to be stored for a long time, they must be kept in moisture-free, vibration-free, clean and well-ventilated places, and the insulation resistance must be measured before they are put into service and the windings must be dried if necessary.

Bearings

High-quality, sound controlled, lubricated for life by the manufacturer, single-row deep groove ball bearings closed on both sides (ZZ) are used in the motors.

SINGLE PHASE MOTORS

Frame Size	71	80	90	100
SINGLE PHASE (M21D)				
Cable entry gland		M20		
No of glands		1		
Largest cable outer diameter mm ²		14		
Largest total conductor cross section (mm ²)		2.5		
SINGLE PHASE (MK21D - MS21D)				
Cable entry gland		M16		
No of glands		1		
Largest cable outer diameter mm ²		10		
Largest total conductor cross section (mm ²)		2.5		

Standard Design with Fixed Ball Bearing

Frame Size	No of Poles	Front Bearing	Rear Bearing	Figure Nr.
71	2 & 4	6202 ZZ	6202 ZZ	1
80	2 & 4	6204 ZZ	6202 ZZ	
90	2 & 4	6205 ZZ	6203 ZZ	
100	2 & 4	6206 ZZ	6204 ZZ	

In cases required by the application, M21D and MS21D motors are manufactured in the fixed bedding arrangement in Figure 3 upon request in order to prevent the axial movement of the shaft.

Orders of Bearings

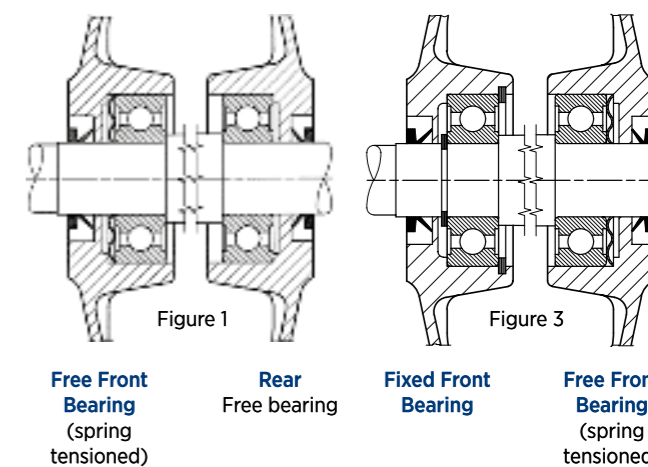

Allowable Mechanical Forces

Allowable radial forces (Axial force $F_a = 0$)

Frame Size	3000 RPM		1500 RPM	
	F_{x_0} (N)	$F_{x_{max}}$ (N)	F_{x_0} (N)	$F_{x_{max}}$ (N)
71	400	340	500	420
80	660	540	840	680
90	730	600	910	720
100	1030	820	1300	1050

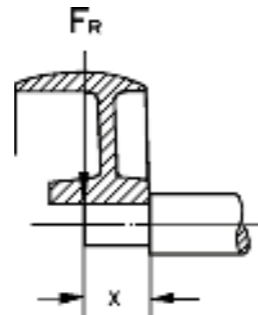

Permissible Axial External Forces

Frame Size	HORIZONTAL SHAFT				VERTICAL SHAFT									
	Pulling		Pushing		Shaft / Down				Shaft / Up					
	$F_r = 0$		$F_r = 0$		Force Down		Force Up		Force Down		Force Up		$F_r = 0$	
	max. F_r		max. F_r		max. F_r		max. F_r		max. F_r		max. F_r		max. F_r	
	at X_0	at X_{max}	at X_0	at X_{max}	at X_0	at X_{max}	at X_0	at X_{max}	at X_0	at X_{max}	at X_0	at X_{max}	at X_0	at X_{max}
	N	N	N	N	N	N	N	N	N	N	N	N	N	N

2 poles (3000 RPM)

71	100	190	160	230	90	90	90	190	170	250	170	140	220	110	110	110
80	140	320	270	400	120	120	120	340	290	430	300	240	390	160	160	160
90	160	350	290	430	130	130	130	370	320	470	310	250	400	190	190	190
100	220	490	400	590	170	170	170	520	440	650	420	330	540	270	270	270

4 poles (1500 RPM)

71	100	280	250	350	90	90	90	290	260	370	260	220	340	120	120	120
80	140	490	420	610	120	120	120	510	440	640	460	390	590	170	170	170
90	160	530	440	650	120	120	120	570	480	700	480	400	610	200	200	200
100	220	740	630	880	150	150	150	790	670	960	650	540	830	290	290	290

Voltage and Frequency

Single phase motors are manufactured in conformance with the 220 V nominal voltage and 50 Hz frequency. Upon request, they can be manufactured in conformance with the 110 V, 230 V, 240 V network voltages and 60 Hz frequency. Variations of 5% in nominal voltage and frequency practically do not cause any change in motor power. The temperature of motors continuously operating at the lower and upper limit values of the allowable voltage variation may exceed the allowable temperature rise limit by maximum 10K according to the winding insulation class.

Nominal Power

The nominal power P_N is the mechanical power specified on the name plate that the shaft delivers at nominal values. The effective power P_1 is the power drawn by the motor from the network, and it is greater than the mechanical power that the shaft delivers due to losses.

$$P_1 (W) = U \cdot I \cdot \cos \varphi$$

Efficiency η , is the division of the mechanical power to the effective power. The efficiencies given in the catalog are calculated by the direct measurement method according to IEC 60034-2-1:2014.

The nominal powers given in this catalog are the mechanical powers delivered by the motor shaft at nominal voltage and frequency, at 40°C ambient temperature, at locations up to 1000 m above sea level and in continuous operation (S1) type.

Nominal Torque

The torque delivered by the motor shaft.
Nominal torque (Nm) = 9550

Nominal Power (kW)
Nominal Speed (RPM)

Motor torque at start-up must always be higher than the counter torque of the operating machine.

! Since the rotating field in single-phase motors is created by using one phase of the network, it creates a lower start-up torque compared to 3-phase motors. Vibration and sound level are higher than 3-phase motors. Therefore, in cases where single-phase motors should be used instead of 3-phase motors, please contact our company.

Changing the Direction of Rotation

Single-phase motors are suitable for operation in both directions of rotation like 3-phase motors. The direction of rotation of permanent capacitor motors is changed according to the connection diagram below.

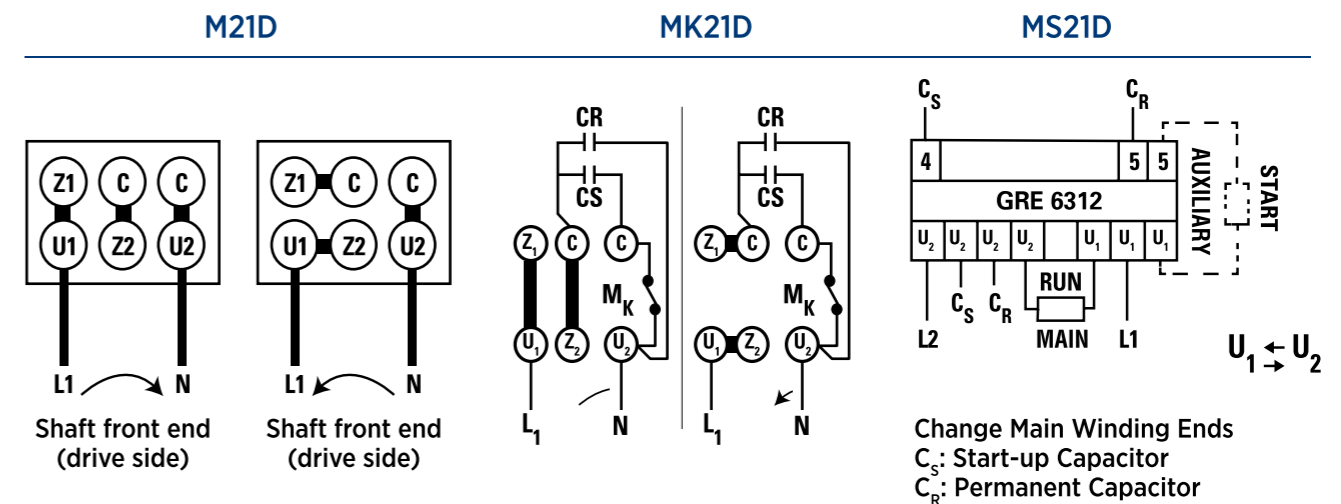

The direction of rotation of MK21D motors is changed according to the connection diagram. In Start-up + Permanent capacitor motors, the motor rotation direction is changed by changing the main winding ends of the electronic start-up relay. Before the motors are connected to the opposite work machine, the direction of rotation should be checked by making quick opening/closing once.

Idling

The voltage built up on the capacitors used in single-phase motors reaches the highest value in no-load operation, thus the life of the capacitor shortens; also, single-phase motors should not be run idle for a long time, since the losses in idle operation are higher than working at full load. In cases where long-term idling is required, please contact our company as a special winding design may be required for the application.

SINGLE PHASE MOTORS
Standard Series
Single Phase Motors

SINGLE PHASE MOTORS
Standard Series
Single Phase Motors

OPERATIONAL CHARACTERISTICS
Motors with Permanent Circuit Capacitor **M21D**

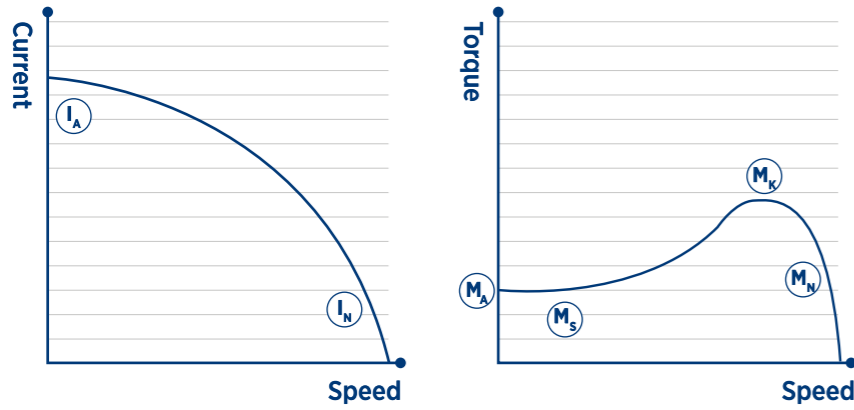

1 Phase, 220 V, 50 Hz
Operation Type S1 (Continuous Operation)
Protection Degree IP 55
Insulation Class F (155 °C)
Heat Increase Limit B (80 K)

OPERATIONAL CHARACTERISTICS
Motors with Start-up + Design with Permanent Circuit **MS21D**

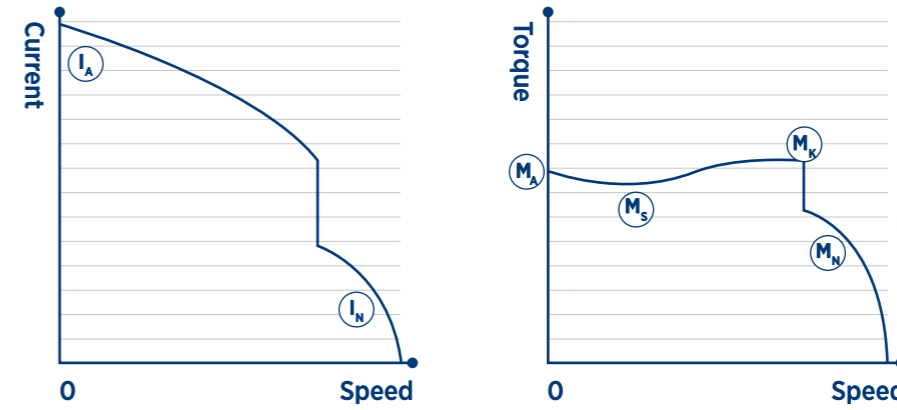

1 Phase, 220 V, 50 Hz
Operation Type S1 (Continuous Operation)
Protection Degree IP 55
Insulation Class F (155 °C)
Heat Increase Limit B (80 K)

Nominal Power kW	Type	At Nominal Power					At Start-up		Tilting Moment Ratio M_K / M_N	Permanent Circuit Capacitor μF	Moment of Inertia J kgm ²	Approx. Weight kg
		Speed RPM	Current I_N A	Torque M_N Nm	Power Coefficient Cos ϕ	Efficiency η %	Current Ratio I_A / I_N	Torque Ratio M_A / M_N				

Nominal Power kW	Type	At Nominal Power					At Start-up		Tilting Moment Ratio M_K / M_N	Start-up Capacitor 330 V μF	Permanent Circuit Capacitor 400 V μF	Moment of Inertia J kgm ²	Approx. Weight kg
		Speed RPM	Current I_N A	Torque M_N Nm	Power Coefficient Cos ϕ	Efficiency η %	Current Ratio I_A / I_N	Torque Ratio M_A / M_N					

2 poles (3000 RPM)

0,18	M21D 71 M 2a	2860	1,3	0,6	0,94	68,0	4,2	0,80	1,8	8	0,00022	4,9
0,25	M21D 71 M 2b	2820	1,65	0,85	0,96	74,0	4,2	0,60	1,8	8	0,00025	5,5
0,37	M21D 71 M 2c	2840	2,5	1,25	0,96	70,0	4,0	0,70	2,0	15	0,00028	6
0,55	M21D 71 M 2d	2820	3,9	1,86	0,96	67,0	4,0	0,60	1,9	20	0,00031	6,6
0,37	M21D 80 M 2a	2880	2,5	1,22	0,97	69,0	3,8	0,70	2,0	15	0,00034	7,3
0,55	M21D 80 M 2b	2880	4,0	1,82	0,95	66,0	4,0	0,50	2,1	20	0,00043	8,2
0,75	M21D 80 M 2c	2890	5,2	2,48	0,96	68,0	3,8	0,60	2,0	30	0,00056	9,1
1,1	M21D 80 M 2d	2870	7,0	3,66	0,95	75,0	3,7	0,40	2,0	35	0,00070	10,1
0,75	M21D 90 S 2a	2850	5,6	2,51	0,92	66,0	4,3	0,50	1,9	30	0,00066	11,5
1,1	M21D 90 S 2b	2880	8,0	3,75	0,90	69,5	4,3	0,55	2,1	35	0,00093	12,1
1,5	M21D 90 S 2c	2890	10,0	4,95	0,85	80,0	4,3	0,60	2,3	40	0,00113	13,2
1,8	M21D 90 L 2d	2870	12,5	6,0	0,95	69,0	4,2	0,35	1,9	50	0,00141	14,5
2,2	M21D 90 L 2e	2870	13,8	7,3	0,94	77,0	4,4	0,50	1,9	60	0,00161	15,6
3	M21D 100 L 2a	2860	19,0	10,0	0,95	80,0	4,6	0,40	2,0	60	0,00260	23

2 poles (3000 RPM)

0,18	MS21D 71 M 2a	2860	1,30	0,60	0,94	68,0	4,9	2,40	1,8	21-25	8	0,00022	4,9
0,25	MS21D 71 M 2b	2820	1,65	0,85	0,96	74,0	4,9	2,30	1,8	30-36	8	0,00025	5,5
0,37	MS21D 71 M 2c	2840	2,50	1,25	0,96	70,0	4,7	2,10	2,0	53-64	15	0,00028	6
0,55	MS21D 71 M 2d	2820	3,90	1,86	0,96	67,0	4,7	2,50	1,9	108-130	20	0,00031	6,6
0,37	MS21D 80 M 2a	2880	2,50	1,22	0,97	69,0	4,5	2,60	2,0	53-64	15	0,00034	7,3
0,55	MS21D 80 M 2b	2880	4,0	1,82	0,95	66,0	4,7	2,60	2,1	88-106	20	0,00043	8,2
0,75	MS21D 80 M 2c	2890	5,20	2,48	0,96	68,0	4,5	2,70	2,0	88-106	30	0,00056	9,1
1,1	MS21D 80 M 2d	2870	7,00	3,66	0,95	75,0	4,4	2,90	2,0	130-156	35	0,00070	10,1
0,75	MS21D 90 S 2a	2850	5,60	2,51	0,92	66,0	5,0	2,30	1,9	88-106	30	0,00066	11,5
1,1	MS21D 90 S 2b	2880	8,0	3,75	0,90	69,5	5,0	2,40	2,1	145-174	35	0,00093	12,1
1,5	MS21D 90 S 2c	2890	10,0	4,95	0,85	80,0	5,0	2,90	2,3	233-280/250V	40	0,00113	13,2
1,8	MS21D 90 L 2d	2870	12,5	6,0	0,95	69,0	4,9	2,90	1,9	233-280/250V	50	0,00141	14,5
2,2	MS21D 90 L 2e	2870	13,8	7,30	0,94	77,0	5,1	2,50	1,9	288-331/250V	60	0,00161	15,6
3	MS21D 100 L 2a	2860	19,0	10,0	0,95	80,0	5,3	2,30	2,0	288-331/250V	60	0,00260	23

4 poles (1500 RPM)

0,12	M21D 71 M 4a	1440	1,30	0,80	0,85	55,0	3,5	0,80	1,8	8	0,00035	5,05
0,18	M21D 71 M 4b	1420	1,50	1,22	0,95	57,5	3,5	0,50	1,8	8	0,00039	5,5
0,25	M21D 71 M 4c	1410	2,00	1,70	0,90	63,5	3,8	0,40	1,8	10	0,00048	5,96
0,37	M21D 71 M 4d	1400	3,20	2,52	0,88	60,0	3,7	0,45	1,8	15	0,00056	6,5
0,37	M21D 80 M 4a	1400	2,70	2,50	0,94	66,0	3,6	0,40	1,8	15	0,00071	8,1
0,55	M21D 80 M 4b	1400	4,20	3,75	0,92	65,0	3,8	0,40	1,8	20	0,00092	8,9
0,75	M21D 80 M 4c	1400	5,70	5,10	0,86	70,0	3,8	0,50	1,8	30	0,00123	9,9
0,55	M21D 90 S 4a	1420	4,50	3,70	0,90	62,0	4,3	0,50	2,0	30	0,00187	10,9
0,75	M21D 90 S 4b	1410	5,50	5,10	0,90	69,0	4,3	0,50	2,0	30	0,00209	11,8
1,1	M21D 90 S 4c	1400	7,10	7,50	0,95	74,0	4,4	0,40	1,8	35	0,00239	12,9
1,5	M21D 90 L 4d	1420	10,2	10,1	0,92	73,0	4,2	0,40	1,9	50	0,00265	14,9
1,8	M21D 100 L 4a	1440	12,5	12,1	0,94	70,0	4,1	0,50	2,0	50	0,00370	23,9
2,2	M21D 100 L 4b	1440	13,4	14,6	0,95	78,5	4,1	0,40	2,0	60	0,00440	24,5
3	M21D 100 L 4c	1420	18,5	19,9	0,94	78,0	3,5	0,30	1,8	60	0,00510	25,5

4 poles (1500 RPM)

0,12	MS21D 71 M 4a	1440	1,30	0,80	0,85	55,0	4,0	2,0	1,8	36-43	8	0,00035	5,05
0,18	MS21D 71 M 4b	1420	1,50	1,22	0,95	57,5	4,0	2,0	1,8	36-43	8	0,00039	5,5
0,25	MS21D 71 M 4c	1410	2,00	1,70	0,90	63,5	4,3	2,30	1,8	36-43	10	0,00048	5,96
0,37	MS21D 71 M 4d	1400	3,20	2,52	0,88	60,0	4,3	2,30	1,8	53-64	15	0,00056	6,5
0,37	MS21D 80 M 4a	1400	2,70	2,50	0,94	66,0	4,3	2,10	1,8	53-64	15	0,00071	8,1
0,55	MS21D 80 M 4b	1400	4,20	3,75	0,92	65,0	4,5	2,60	1,8	88-106	20	0,00092	8,9
0,75	MS21D 80 M 4c	1400	5,70	5,10	0,86	70,0	4,5	2,90	1,8	88-106	30	0,00123	9,9
0,55	MS21D 90 S 4a	1420	4,50	3,70	0,90	62,0	5,0	2,50	2,0	88-106	30	0,00187	10,9
0,75	MS21D 90 S 4b	1410	5,50	5,10	0,90	69,0	5,0	2,50	2,0	130-156	30	0,00209	11,8
1,1	MS21D 90 S 4c	1400	7,10	7,50	0,95	74,0	5,1	2,30	1,8	161-193	35	0,00239	12,9
1,5	MS21D 90 L 4d	1420	10,2	10,1	0,92	73,0	4,9	2,40	1,9	161-193	50	0,00265	14,9
1,8	MS21D 100 L 4a	1440	12,5	12,1	0,94	70,0	4,8	2,40	2,0	288-331/250V	50	0,00370	23,9
2,2	MS21D 100 L 4b	1440	13,4	14,6	0,95	78,5	4,8	2,30	2,0	288-331/250V	60	0,00440	24,5
3	MS21D 100 L 4c	1420	18,5	19,9	0,94	78,0	4,6	2,10	1,8	288-331/250V	60	0,00510	25,5

Standard Series Single Phase Motors

MS21D

OPERATIONAL CHARACTERISTICS

Motors with Start-up + Design with Permanent Circuit

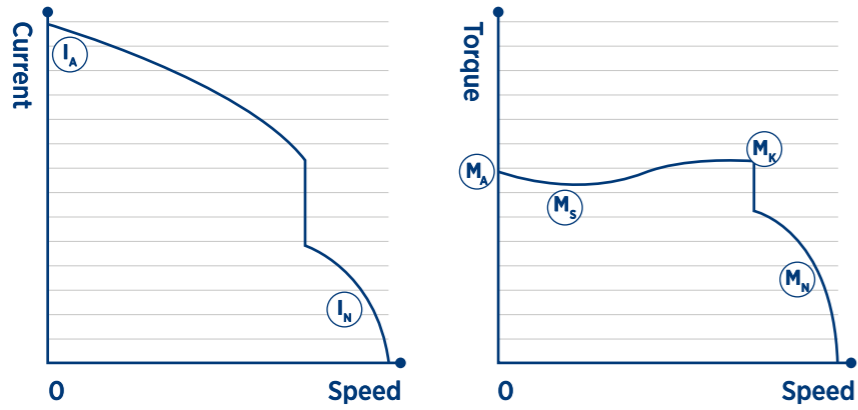

1 Phase, 220 V, 50 Hz
Operation Type S1 (Continuous Operation)
Protection Degree IP 55
Insulation Class F (155 °C)
Heat Increase Limit B (80 K)

Nominal Power kW	Type	At Nominal Power					At Start-up		Tilting Moment Ratio M_K / M_N	Start-up Capacitor 330 V μF	Permanent Circuit Capacitor 400V μF	Moment of Inertia J kgm ²	Approx. Weight kg
		Speed d/dak	Current I_N A	Torque M_N Nm	Power Coefficient $\cos \phi$	Efficiency η %	Current Ratio I_A / I_N	Torque Ratio M_A / M_N					

2 poles (3000 RPM)

0,18	MK21D 71 M 2a	2860	1,30	0,60	0,94	68,0	4,9	2,40	1,8	21-25	8	0,00022	4,9
0,25	MK21D 71 M 2b	2820	1,65	0,85	0,96	74,0	4,9	2,30	1,8	30-36	8	0,00025	5,5
0,37	MK21D 71 M 2c	2840	2,50	1,25	0,96	70,0	4,7	2,10	2,0	53-64	15	0,00028	6
0,55	MK21D 71 M 2d	2820	3,90	1,86	0,96	67,0	4,7	2,50	1,9	108-130	20	0,00031	6,6
0,37	MK21D 80 M 2a	2880	2,50	1,22	0,97	69,0	4,5	2,60	2,0	53-64	15	0,00034	7,3
0,55	MK21D 80 M 2b	2880	4,0	1,82	0,95	66,0	4,7	2,60	2,1	88-106	20	0,00043	8,2
0,75	MK21D 80 M 2c	2890	5,20	2,48	0,96	68,0	4,5	2,70	2,0	88-106	30	0,00056	9,1
1,1	MK21D 80 M 2d	2870	7,0	3,66	0,95	75,0	4,4	2,90	2,0	130-156	35	0,00070	10,1
0,75	MK21D 90 S 2a	2850	5,60	2,51	0,92	66,0	5,0	2,3	1,9	88-106	30	0,00066	11,5
1,1	MK21D 90 S 2b	2880	8,0	3,75	0,90	69,5	5,0	2,40	2,1	145-174	35	0,00093	12,1
1,5	MK21D 90 S 2c	2890	10,0	4,95	0,85	80,0	5,0	2,90	2,3	233-280/250V	40	0,00113	13,2
1,8	MK21D 90 L 2d	2870	12,5	6,00	0,95	69,0	4,9	2,90	1,9	233-280/250V	50	0,00141	14,5
2,2	MK21D 90 L 2e	2870	13,8	7,30	0,94	77,0	5,1	2,50	1,9	288-331/250V	60	0,00161	15,6
3	MK21D 100 L 2a	2860	19,0	10,0	0,95	80,0	5,3	2,30	2,0	288-331/250V	60	0,00260	23

4 poles (1500 RPM)

0,12	MK21D 71 M 4a	1440	1,30	0,80	0,85	55,0	4,0	2,00	1,8	36-43	8	0,00035	5,05
0,18	MK21D 71 M 4b	1420	1,50	1,22	0,95	57,5	4,0	2,00	1,8	36-43	8	0,00039	5,5
0,25	MK21D 71 M 4c	1410	2,00	1,70	0,90	63,5	4,3	2,30	1,8	36-43	10	0,00048	5,96
0,37	MK21D 71 M 4d	1400	3,20	2,52	0,88	60,0	4,3	2,30	1,8	53-64	15	0,00056	6,5
0,37	MK21D 80 M 4a	1400	2,70	2,50	0,94	66,0	4,3	2,10	1,8	53-64	15	0,00071	8,1
0,55	MK21D 80 M 4b	1400	4,20	3,75	0,92	65,0	4,5	2,60	1,8	88-106	20	0,00092	8,9
0,75	MK21D 80 M 4c	1400	5,70	5,10	0,86	70,0	4,5	2,90	1,8	88-106	30	0,00123	9,9
0,55	MK21D 90 S 4a	1420	4,50	3,70	0,90	62,0	5,0	2,50	2,0	88-106	30	0,00187	10,9
0,75	MK21D 90 S 4b	1410	5,50	5,10	0,90	69,0	5,0	2,50	2,0	130-156	30	0,00209	11,8
1,1	MK21D 90 S 4c	1400	7,10	7,50	0,95	74,0	5,1	2,30	1,8	161-193	35	0,00239	12,9
1,5	MK21D 90 L 4d	1420	10,2	10,1	0,92	73,0	4,9	2,40	1,9	161-193	50	0,00265	14,9
1,8	MK21D 100 L 4a	1440	12,5	12,1	0,94	70,0	4,8	2,40	2,0	288-331/250V	50	0,00370	23,9
2,2	MK21D 100 L 4b	1440	13,4	14,6	0,95	78,5	4,8	2,30	2,0	288-331/250V	60	0,00440	24,5
3	MK21D 100 L 4c	1420	18,5	19,9	0,94	78,0	4,6	2,10	1,8	288-331/250V	60	0,00510	25,5

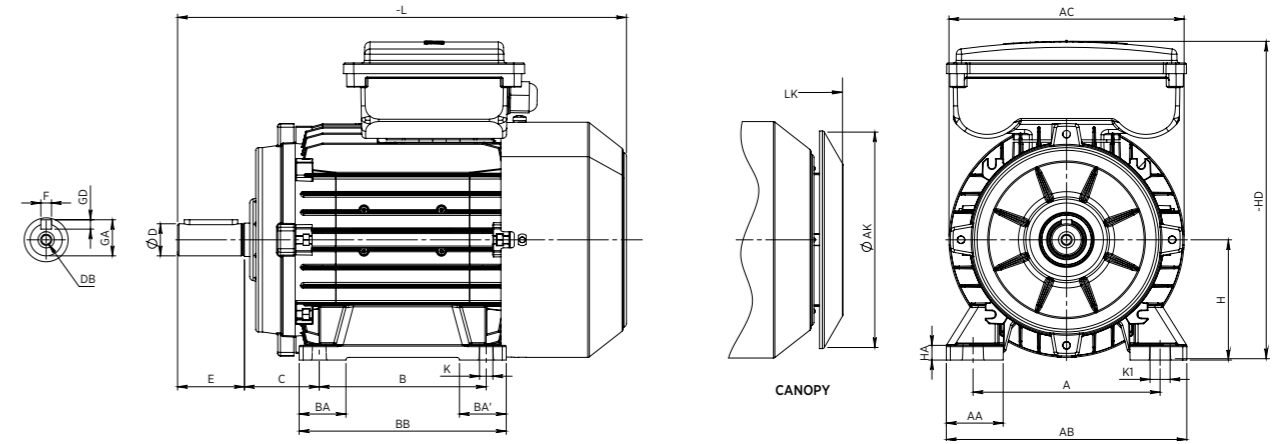

FOOT-MOUNTED MOTOR - B3, B6, B7, B8, B15, V5, V6

Frame Size	H	HD 1	HD 2	HA	A	AA	AB	ACØ	AKØ	KØ	K1	B	BA	BB	L	LK	C	E EA	DB DC	DØ DAØ	GA GC	FxGD FxGF
71	71	195	185	10	112	33	140	138	116	7	11	90	27	108	249	278	45	30	M5	14	16	5x5
80	80	211	211	10	125	38	160	156	151	10	15	100	33	125	282	308	50	40	M6	19	21,5	6x6
90-S	90	228	240	12	140	43	180	176	151	10	15	100	35	130	301*	338*	56	40*	M6*	19*	21,5*	6x6*
90-L	90	228	240	12	140	43	180	176	151	10	15	125	35	155	334	363	56	50	M8	24	27	8x7
100	100	258	260	13	160	47	200	195	189	12	18	140	39	175	382	413	63	60	M10	28	31	8x7

* For motors 90S 2c - 90S 4c L=311, LK=348, E=50, DB=M8, ØD=24, GA=27, FxGD=8x7
 ** AD 1 is for M21D, AD 2 is for MK21D and MS21D 2.

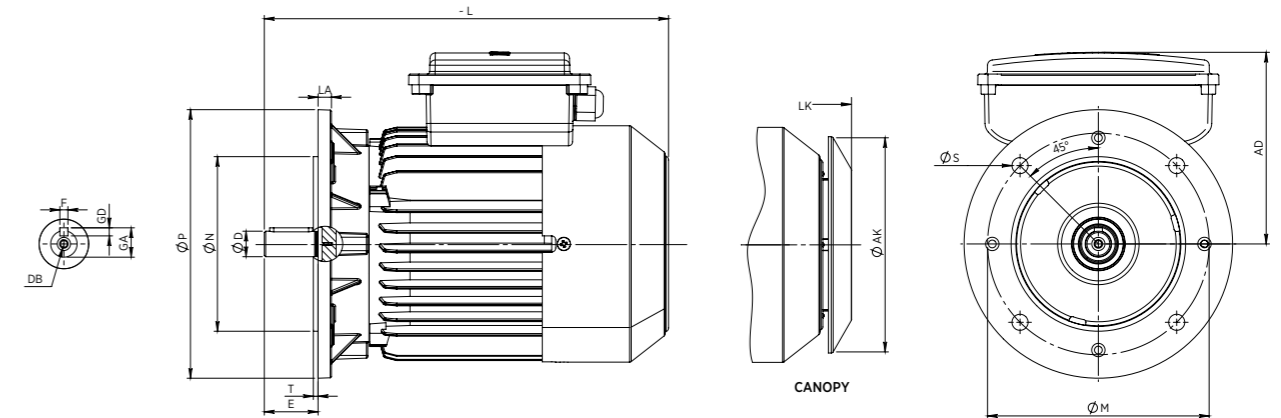

FOOT-MOUNTED MOTOR AND FLANGE (FORM "A" - DIN EN 50 347) - B35

Frame Size	Flange Nr.	MØ	NØ	PØ	Fixing Hole		T	LA	AD1	AD2	AKØ	L	LK	E EA	DB DC	DØ DAØ	GA GC	FxGD FxGF
					Quantity	SØ												
71	FF 130	130	110	160	4	10	3,5	10	124	114	116	249	278	30	M5	14	16	5x5
80	FF 165	165	130	200	4	12	3,5	12	131	131	151	282	308	40	M6	19	21,5	6x6
90-S	FF 165	165	130	200	4	12	3,5	12	138	148	151	301*	338*	40*	M6*	19*	21,5*	6x6*
90-L	FF 165	165	130	200	4	12	3,5	12	138	148	151	334	363	50	M8	24	27	8x7
100	FF 215	215	180	250	4	14,5	4	15	159	156	189	382	413	60	M10	28	31	8x7

* For motors 90S 2c - 90S 4c L=311, LK=348, E=50, DB=M8, ØD=24, GA=27, FxGD=8x7
 ** AD 1 is for M21D, AD 2 is for MK21D and MS21D 2.

SINGLE PHASE MOTORS / MOTOR DIMENSIONS

Standard Series Single Phase Motors

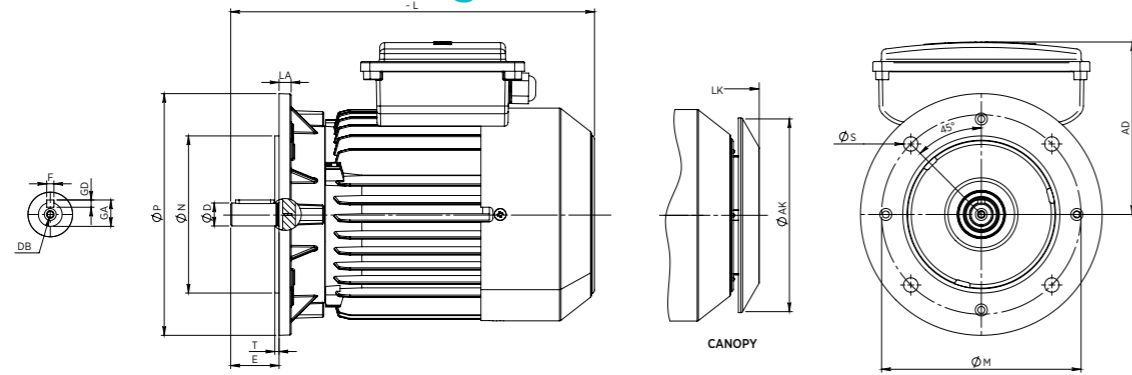

FOOT-MOUNTED MOTOR- B3, B6, B7, B8, B15, V5, V6

Note: The spindle collar and flange seating surface are in the same plane.

Frame Size	H	HD1	HD2	HA	A	AA	AB	AC	AKØ	KØ	K1	B	BA	BB	Flange Nr.	MØ	NØ	PØ	No	SØ	T	LA	L	LK	C	E	EA	DB	DC	DØ	DAØ	GA	GC	FxGD	FxGF
71	71	195	185	10	112	33	140	-	116	7	11	90	27	108	FF130	130	110	160	4	10	3,5	10	249	278	45	30	M5	14	16			5x5			
80	80	211	211	10	125	38	160	-	151	10	15	100	33	125	FF165	165	130	200	4	12	3,5	10	282	308	50	40	M6	19	21,5			6x6			
90-S	90	228	240	12	140	43	180	-	151	10	15	100	35	130	FF165	165	130	200	4	12	3,5	12	301*	338*	56	40*	M6*	19*	21,5*			6x6*			
90-L	90	228	240	12	140	43	180	-	151	10	15	125	35	155	FF165	165	130	200	4	12	3,5	12	334	363	56	50	M8	24	27			8x7			
100	100	258	260	13	160	47	200	-	189	12	18	140	39	175	FF215	215	180	250	4	14,5	4	15	382	413	63	60	M10	28	31			8x7			

* For motors 90S 2c - 90S 4c L=311, LK=348, E=50, DB=M8, ØD=24, GA=27, FxGD=8x7
 ** HD 1 is for M21D, HD 2 is for MK21D and MS21D 2.

All dimensions are in mm.

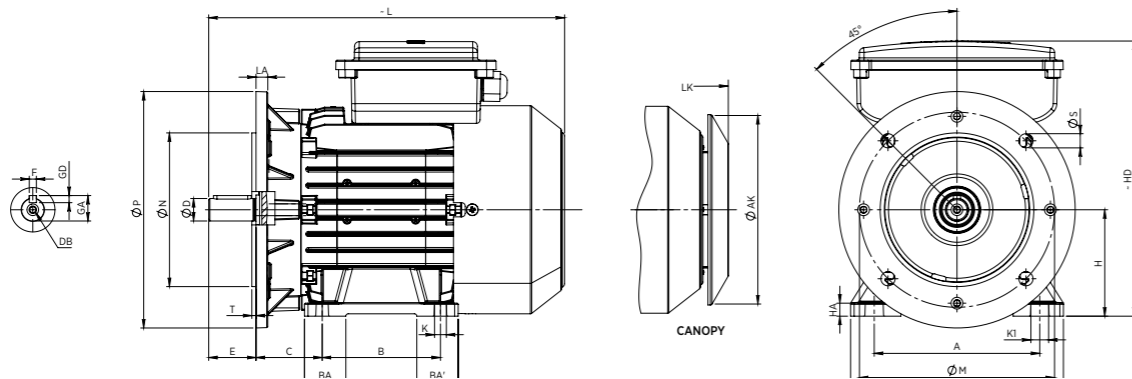

MOTOR WITH FLANGE (FORM "A" - DIN EN 50 347) - B5, V1, V3

Frame Size	Flange Nr.	MØ	NØ	PØ	S	T	ACØ	AKØ	AD1	AD2	L	LK	E	EA	DB	DC	DØ	DAØ	GA	GC	FxGD	FxGF
71	FT 85	85	70	105	M6	2,5	138	116	124	114	249	278	30	M5	14	16						5x5
80	FT 100	100	80	120	M6	3	156	150	131	131	282	308	40	M6	19	21,5						6x6
90-S	FT 115	115	95	140	M8	3	176	150	138	148	301*	338*	40	M6*	19*	21,5*						6x6*
90-L	FT 115	115	95	140	M8	3	176	150	138	148	334	363	50	M8	24	27						8x7
100	FT 130	130	110	160	M8	3,5	194	188	159	156	382	413	60	M10	28	31						8x7

* 90S 2c - 90S 4c Motors L=311, LK=348, E=50, DB=M8, OD=24, GA=27, FxGD=8x7
 ** AD 1 is for M21D, AD 2 is for MK21D and MS21D 2.

SINGLE PHASE MOTORS / MOTOR DIMENSIONS

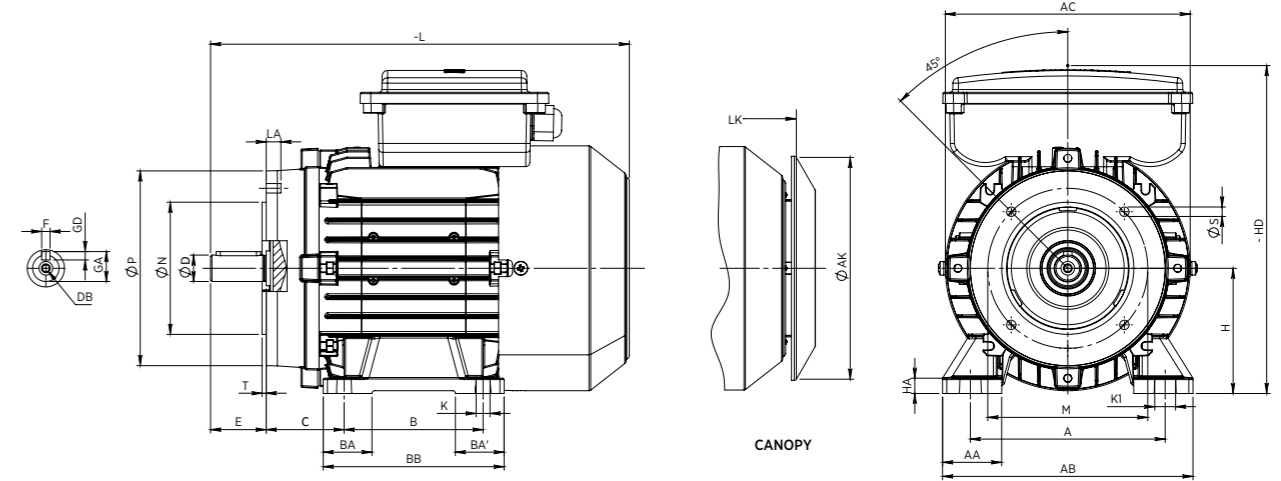

MOTORS FOOT-MOUNTED AND FLANGE (FORM "C" - DIN EN 50 347) - B34

Note: The spindle collar and flange seating surface are in the same plane.

Frame Size	H	HD1	HD2	HA	A	AA	AB	ACØ	AKØ	KØ	K1	B	BA	BB	Flange Nr.	MØ	NØ	PØ	SØ	T	L	LK	C	E	EA	DB	DC	DØ	DAØ	GA	GC	FxGD	FxGF
71	71	195	185	10	112	33	140	138	116	7	11	90	27	108	FT 85	85	70	105	M6	2,5	249	278	45	30	M5	14	16			5x5			
80	80	211	211	10	125	38	160	156	151	10	15	100	33	125	FT 100	100	80	120	M6	3	282	278	50	40	M6	19	21,5			6x6			
90-S	90	228	240	12	140	43	180	176	151	10	15	100	35	130	FT 115	115	95	140	M8	3	301*	338*	56*	40*	M6*	19*	21,5*			6x6*			
90-L	90	228	240	12	140	43	180	176	151	10	15	125	35	155	FT 115	115	95	140	M8	3	334	363	56	50	M8	24	27			8x7			
100	100	258	260	13	160	47	200	195	189	12	18	140	39	175	FT 130	130	110	160	M8	3,5	382	413	63	60	M10	28	31			8x7			

* 90S 2c - 90S 4c Motors L=311, LK=348, E=50, DB=M8, OD=24, GA=27, FxGD=8x7
 ** HD 1 is for M21D, HD 2 is for MK21D and MS21D 2.

All dimensions are in mm.

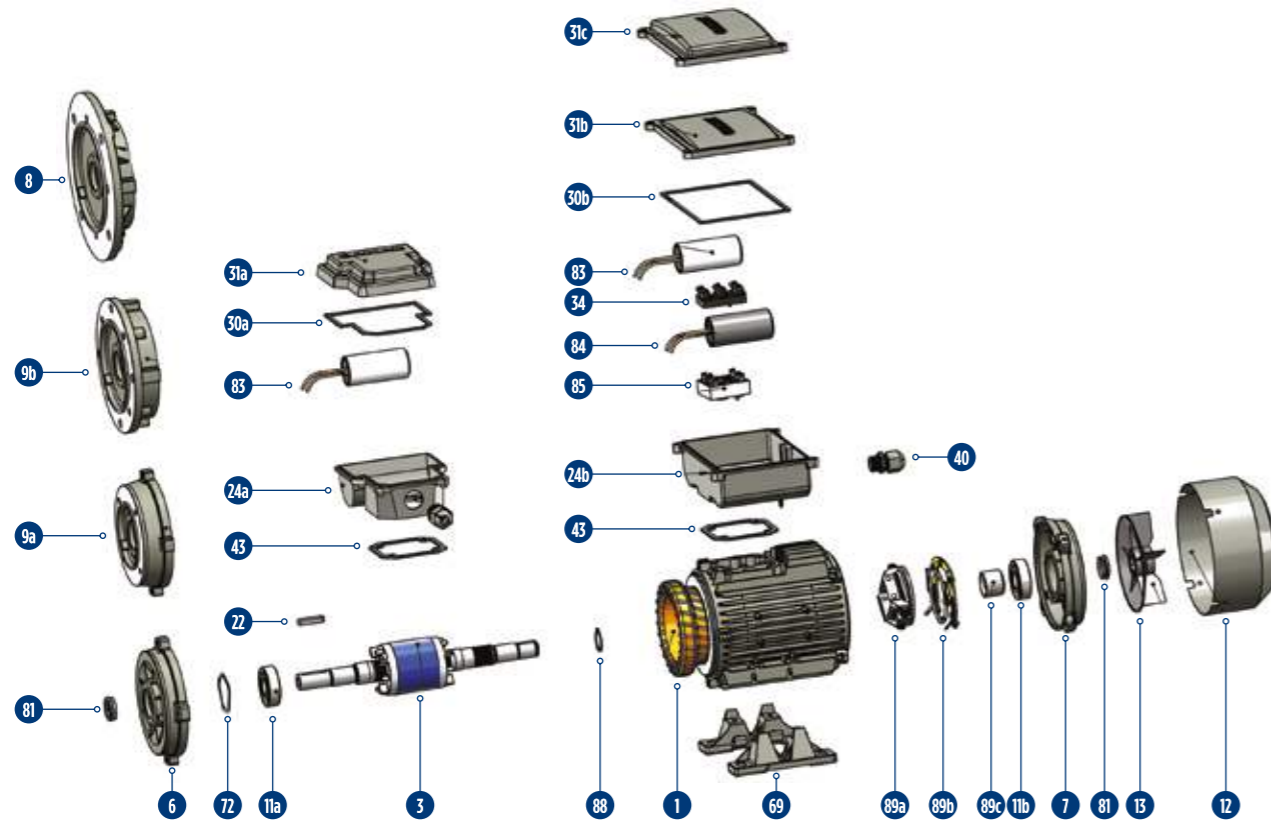

- 1 Stator with complete windings: Varnished and installed to the body
- 3 Complete Rotor: With balanced, shaft, machined (excluding keys)
- 6 Front cover
- 7 Rear cover
- 8 Flange (Form A) B5
- 9a Flange (Form C) B14 FT100
- 9b Flange (Form C) B14-2 FT130
- 11a Front bearing
- 11b Rear bearing
- 12 Fan housing bowl
- 13 Cooling fan
- 22 Shaft end key
- 24a End terminal box - Permanent circuit capacitor design
- 24b End terminal box - Start-up+permanent circuit capacitor design
- 29 Seal- Between end terminal box and motor frame (63)
- 30a Seal (Between terminal box and cover) Permanent circuit capacitor design
- 30b Seal (Between terminal box and cover) Start-up+permanent circuit capacitor design
- 31a End terminal box cover - Permanent circuit capacitor design
- 31b End terminal box cover - Start-up+permanent circuit capacitor design
- 31c End terminal box cover - Start-up+permanent circuit capacitor design (Deep cover)
- 34 Connector
- 40 Cable entry gland
- 43 Seal- Between end terminal box and motor frame (100-112)
- 69 Foot Mounted
- 72 Disc spring
- 81 Rubber dust seal (V-ring) or optional oil seal
- 83 Permanent circuit capacitor
- 84 Start-up (first movement) capacitor
- 85 Electronic start-up relay (Start-up+permanent circuit condenser motors)
- 88 Inner ring
- 89a Centrifugal spring (rotor)
- 89b Centrifugal contact (stator)

NEW SERIES MOTORS



OPERATIONAL CHARACTERISTICS
3 Phase, 400 V, 50 Hz | Type of Operation: S1 (Continuous Operation)
Protection Degree: IP 55 | Insulation Class F (155°C) | Heat Increase Limit: B (80K)

ALUMINUM FRAME

2 poles - 3000 RPM

While the new series motors offer flexible and practical solutions with their options, they create privileges with their high performance. In this series, different from the standard series, new serie offers attachable and fixed feet frame options.

Attachable Feet Housings (for aluminum model): In the aluminum body, the mounting feet can be installed and disassembled between the frame sizes 80-200 in such a way that the terminal box can face to 3 directions, and in frame size 71, the terminal box is on the top.

Fixed Feed Housing:

Frame sizes 71-200 Alumimun housings are casted with feet during production.

Housing and Flanges:

The materials used in the motor bodies, bearing carrier covers and flanges are given in the following table according to their size.

Frame Size	Frame	Covers	Flanges			Attachable Feet Housing	
			B5	B14/Small	B14/Large	Aluminum Frame	Cast Iron Frame
71	Aluminum	Aluminum	Aluminum	Aluminum	Aluminum	-	-
80	Aluminum	Aluminum	Aluminum	Aluminum	Aluminum	-	-
90	Aluminum	Aluminum	Aluminum	Aluminum	Aluminum	-	-
100	Aluminum	Aluminum	Aluminum	Aluminum	Aluminum	-	-
112	Aluminum	Aluminum	Aluminum	Aluminum	Aluminum	-	-
132	Aluminum or Cast Iron	Aluminum or Cast Iron	Aluminum or Cast Iron	Cast Iron	Cast Iron	Yes	-
160			-	-	-	No	-
180			-	-	-	-	-
200			Cast Iron	-	-	-	-
225			-	-	-	-	-

Nominal Power kW	Type	At Nominal Power					At Start-up				Tilting Moment Ratio	Moment of Inertia	Approx. Weight		
		Speed	Current	Torque	Power Coefficient Cos φ	Efficiency η			Current Ratio					Torque Ratio	
		RPM	A	Nm		4/4	3/4	1/2	Direct	Y/Δ				Direct	Y/Δ
0,75	CAGM2EL M 71 2c	2780	1,75	2,6	0,80	77,4	77,2	74,2	4,5	-	2,2	-	2,4	0,00039	7
0,75	AGM2EL 80 M 2a	2860	1,70	2,5	0,82	77,4	77,4	74,6	6,2	-	2,5	-	3	0,00053	8,2
1,1	AGM2EL 80 M 2b	2880	2,30	3,6	0,87	79,6	79,6	77,9	6,3	-	2,7	-	3	0,00066	9,2
1,5	CAGM2EL 80 M 2c	2880	3,30	5,0	0,81	81,3	81,3	80,1	6,3	-	2,3	-	3	0,001	10,4
1,5	AGM2EL 90 S 2a	2880	3,30	5,0	0,81	81,3	81,3	79,8	6,3	-	2,3	-	3	0,0011	11,9
2,2	AGM2EL 90 L 2b	2870	4,50	7,3	0,85	83,2	83,2	81,9	6,6	-	2,6	-	3,1	0,0014	15,2
3	CAGM2EL 90 L 2c	2880	5,80	9,9	0,88	84,6	84,6	83,8	6	-	2,5	-	3	0,0019	18,1
3	AGM2EL 100 L 2a	2880	5,80	9,9	0,88	84,6	84,6	84,1	6	-	2,5	-	3	0,0025	21,2
4	CAGM2EL 100 L 2b	2880	7,90	13,3	0,84	86,6	86,5	86,0	7,2	2,3	2,8	0,9	3	0,0031	22,5
4	AGM2EL 112 M 2a	2880	7,90	13,3	0,85	85,8	85,8	85,6	7,2	2,3	2,8	0,9	3,5	0,0039	25,2
5,5	CAGM2EL 112 M 2b	2905	9,90	18,1	0,92	87,0	87,0	86,5	6,2	2	2	0,6	2,5	0,0045	28,2
7,5	CAGM2EL 112 H 2c	2910	13,6	24,6	0,90	88,1	88,1	87,5	6,2	2	2	0,6	2,5	0,0062	29,5
5,5	AGM2EL 132 S 2a	2905	9,85	18,1	0,93	87,0	87,0	86,5	6,5	2,1	2,2	0,7	2,5	0,013	41
7,5	AGM2EL 132 S 2b	2910	13,6	24,6	0,90	88,1	88,1	87,9	7,2	2,3	2,8	0,9	3	0,014	50
9,2	CAGM2EL 132 S 2c	2910	16,5	30,2	0,91	88,8	88,8	89,0	6,5	2,1	2,1	0,7	2,7	0,018	55
11	CAGM2EL 132 M 2d	2945	19,4	35,7	0,92	89,4	89,4	88,6	6,5	2,1	2,1	0,7	2,6	0,021	63
11	AGM2EL 160 M 2a	2945	19,3	35,7	0,92	89,4	89,4	88,6	6,6	2,1	2	0,6	2,6	0,027	82
15	AGM2EL 160 M 2b	2945	26,1	48,6	0,92	90,3	90,3	89,7	7,2	2,3	2,1	0,7	2,8	0,035	93,8
18,5	AGM2EL 160 L 2c	2950	32,3	59,9	0,91	90,9	90,8	90,1	7,7	2,5	2,5	0,8	3	0,043	110,3
22	CAGM2EL 160 L 2d	2950	38,0	71,2	0,92	91,3	91,3	90,8	7,1	2,3	2,3	0,7	2,9	0,05	120
22	AGM2EL 180 M 2a	2950	38,3	71,2	0,91	91,3	91,3	90,8	8,2	2,6	3	1	3,5	0,066	122
30	CAGM2EL 180 L 2b	2970	52,0	96,5	0,91	92,0	92,0	91,2	8,3	2,7	2,7	0,9	3	0,09	157
30	AGM2EL 200 L 2a	2970	52,0	96,5	0,91	92,0	92,0	91,2	8,3	2,7	2,7	0,9	3	0,13	142
37	AGM2EL 200 L 2b	2970	65,0	119	0,89	92,5	92,5	91,7	8,3	2,7	2,7	0,9	3	0,15	172
45	CAGM2EL 200 L 2c	2975	77,0	144,5	0,91	92,9	93,0	91,8	8	2,6	2,7	0,9	2,9	0,23	191

OPERATIONAL CHARACTERISTICS
3 Phase, 400 V, 50 Hz | Type of Operation: S1 (Continuous Operation)
Protection De-gree: IP 55 | Insulation Class F (155°C) | Heat Increase Limit: B (80K)

New Series Motors

IE2

ALUMINUM FRAME

Nominal Power	Type	At Nominal Power							At Start-up				Tilting Moment Ratio	Moment of Inertia	Approx. Weight
		Speed	Current	Torque	Power Coefficient Cos φ	Efficiency η			Current Ratio		Torque Ratio				
kW		RPM	A	Nm		4/4	3/4	1/2	Direct	Y/Δ	Direct	Y/Δ			

4 poles (1500 RPM)

0,75	AGM2EL 80 M 4b	1410	2,0	5,1	0,68	79,6	79,6	77,6	4,4	-	2,2	-	2,5	0,0014	10,9
1,1	C.AGM2EL 80 H 4c	1420	2,6	7,4	0,75	81,4	81,4	80,5	5,5	-	3	-	3,3	0,0019	11,2
1,1	AGM2EL 90 S 4a	1420	2,6	7,4	0,75	81,4	81,4	80,5	5,5	-	3	-	3,3	0,0022	13,4
1,5	AGM2EL 90 L 4b	1430	3,5	10	0,75	82,8	82,8	81,5	5,9	-	3	-	3,3	0,003	16,1
2,2	C.AGM2EL 90 H 4c	1420	5,1	14,8	0,74	84,3	84,3	82,5	5	-	2,2	-	2,6	0,004	18,1
2,2	AGM2EL 100 L 4a	1420	4,9	14,8	0,77	84,3	84,3	82,5	5,6	-	2,4	-	2,7	0,0044	23,1
3	AGM2EL 100 L 4b	1435	6,7	20	0,76	85,5	85,7	84,0	6,4	-	2,9	-	3,4	0,0057	25,8
4	C.AGM2EL 100 H 4c	1440	8,5	26,5	0,78	86,6	86,7	85,3	6,6	2,1	2,5	0,8	3,3	0,0076	28,1
4	AGM2EL 112 M 4a	1440	8,4	26,5	0,79	86,6	86,8	85,3	6,6	2,1	2,5	0,8	3,3	0,0106	29,5
5,5	C.AGM2EL 112 M 4b	1465	11,3	35,9	0,80	87,7	88,0	87,2	7	2,3	2,8	0,9	3,5	0,015	36
5,5	AGM2EL 132 S 4a	1465	11,2	35,9	0,81	87,7	87,7	87,2	7	2,3	2,8	0,9	3,5	0,021	38,4
7,5	AGM2EL 132 M 4b	1465	15,4	48,9	0,79	88,7	88,8	88,1	7,1	2,3	2,7	0,9	3,4	0,026	46,5
9,2	C.AGM2EL 132 M 4c	1455	19,3	60,1	0,77	89,8	89,8	89,4	6,6	2,2	2,6	0,9	3,1	0,031	70
11	C.AGM2EL 132 M 4d	1460	21,8	72	0,81	89,8	89,9	89,3	6,8	2,2	2,4	0,8	3	0,039	90
11	AGM2EL 160 M 4a	1460	21,6	72	0,82	89,8	89,9	89,3	6,8	2,2	2,4	0,8	3	0,061	86,3
15	AGM2EL 160 L 4b	1470	29,4	97,4	0,81	90,6	90,7	89,7	7,4	2,4	2,8	0,9	3,2	0,082	94
18,5	C.AGM2EL 160 L 4c	1470	35,0	120,2	0,84	91,2	91,2	90,4	7,7	2,5	3,2	1	3,4	0,1	115
18,5	AGM2EL 180 M 4a	1470	34,5	120,2	0,85	91,2	91,4	90,4	7,7	2,5	3,2	1	3,4	0,13	129
22	AGM2EL 180 L 4b	1470	42,5	142,9	0,82	91,6	91,6	90,6	8,3	2,7	2,7	0,9	3,8	0,15	140
30	C.AGM2EL 180 L 4c	1470	53,7	194,9	0,87	92,3	92,3	92,1	7,8	2,5	2,8	0,9	2,8	0,21	176
30	AGM2EL 200 L 4a	1470	53,5	194,9	0,88	92,3	92,3	92,1	7,8	2,5	2,8	0,9	2,8	0,227	215
37	C.AGM2EL 200 L 4b	1470	67,0	240,4	0,86	92,7	92,7	92,2	7,2	2,3	3	1	3	0,3	225

6 poles (1000 RPM)

0,75	AGM2EL 90 S 6a	920	2,0	7,8	0,71	75,9	75,9	72,4	4	-	2,2	-	2,4	0,0034	11,8
1,1	AGM2EL 90 L 6b	930	2,9	11,3	0,70	78,1	78,1	75,1	4	-	2,2	-	2,4	0,0044	13,6
1,5	AGM2EL 100 L 6a	945	3,6	15,2	0,75	79,8	79,7	76,4	4,5	-	2,2	-	2,4	0,0077	19,3
2,2	AGM2EL 112 M 6a	950	5,4	22,1	0,72	81,8	81,7	78,5	4,7	-	2,2	-	2,5	0,013	26,1
3	AGM2EL 132 S 6a	960	7,1	29,8	0,73	83,3	83,2	80,4	4,6	1,5	1,8	0,6	2,3	0,019	35
4	AGM2EL 132 M 6b	960	9,3	39,8	0,73	84,6	84,5	81,6	4,7	1,5	2	0,6	2,5	0,024	44
5,5	AGM2EL 132 M 6c	960	12,7	54,7	0,73	86,0	86,0	83,1	4,9	1,6	2,2	0,7	2,6	0,032	54,8
7,5	AGM2EL 160 M 6a	975	16,0	73,5	0,78	87,2	87,2	84,5	6,3	2	2,6	0,8	3,5	0,076	82
11	AGM2EL 160 L 6b	970	22,5	108,3	0,80	88,7	88,7	85,7	6,2	2	3	1	3	0,109	108
15	AGM2EL 180 L 6a	965	29,0	148,4	0,83	89,7	89,7	86,8	6,5	2,1	2,4	0,8	3	0,2	147
18,5	AGM2EL 200 L 6a	980	37,1	180,3	0,80	90,4	90,4	87,7	7,2	2,32	2,3	0,7	3,2	0,234	167
22	AGM2EL 200 L 6b	980	43,4	214,4	0,80	90,9	90,9	88,4	6,7	2,3	2,3	0,7	2,8	0,283	187

Efficiency values are calculated by the indirect measurement method in accordance with IEC 60034-2-1: 2014 standard. Additional losses are assessed based on test results performed at variable load values.

OPERATIONAL CHARACTERISTICS
3 Phase, 400 V, 50 Hz | Type of Operation: S1 (Continuous Operation)
Protection De-gree: IP 55 | Insulation Class F (155°C) | Heat Increase Limit: B (80K)

New Series Motors

IE2

CAST IRON FRAME

Nominal Power	Type	At Nominal Power							At Start-up				Tilting Moment Ratio	Moment of Inertia	Approx. Weight
		Speed	Current	Torque	Power Coefficient Cos φ	Efficiency η			Current Ratio		Torque Ratio				
kW		RPM	A	Nm		4/4	3/4	1/2	Direct	Y/Δ	Direct	Y/Δ			

2 poles (3000 RPM)

5,5	GM2EL 132 S 2a	2905	9,85	18,1	0,93	87	87	86,5	6,5	2,1	2,2	0,7	2,5	0,013	45
7,5	GM2EL 132 S 2b	2910	13,6	24,6	0,90	88,1	88,1	87,9	7,2	2,3	2,8	0,9	3	0,014	64,5
9,2	C.GM2EL 132 S 2c	2910	16,5	30,2	0,91	88,8	88,8	89,0	6,5	2,1	2,1	0,7	2,7	0,018	75,4
11	C.GM2EL 132 M 2d	2945	19,4	35,7	0,92	89,4	89,4	88,6	6,5	2,1	2,1	0,7	2,6	0,021	80,4
11	GM2EL 160 M 2a	2945	19,33	35,7	0,92	89,4	89,4	88,6	6,6	2,1	2	0,6	2,6	0,027	105
15	GM2EL 160 M 2b	2945	26,07	48,6	0,92	90,3	90,3	89,7	7,2	2,3	2,1	0,7	2,8	0,035	117
18,5	GM2EL 160 L 2c	2950	32,3	59,9	0,91	90,9	90,8	90,1	7,7	2,5	2,5	0,8	3	0,043	135
22	C.GM2EL 160 L 2d	2950	38,0	71,2	0,92	91,3	91,3	90,8	7,1	2,3	2,3	0,7	2,9	0,05	145
22	GM2EL 180 M 2a	2950	38,3	71,2	0,91	91,3	91,3	90,8	8,2	2,6	3	1	3,5	0,066	158
30	C.GM2EL 180 L 2b	2970	52,0	96,5	0,91	92	92	91,2	8,3	2,7	2,7	0,9	3	0,09	193
30	GM2EL 200 L 2a	2970	52,0	96,5	0,91	92,0	92,0	91,2	8,3	2,7	2,7	0,9	3	0,13	190
37	GM2EL 200 L 2b	2970	65,0	119	0,89	92,5	92,5	91,7	8,3	2,7	2,7	0,9	3	0,15	220
45	C.GM2EL 200 L 2c	2975	77,0	144,5	0,91	92,9	93	91,8	8	2,6	2,7	0,9	2,9	0,18	240
45	GM2EL 225 M 2a	2975	75,0	144,5	0,93	92,9	93,0	91,8	8	2,6	2,4	0,8	2,9	0,23	375
55	C.GM2EL 225 M 2b	2980	94,0	176,3	0,91	93,2	93,2	92,2	7,6	2,5	2,6	0,8	2,7	0,41	430

4 poles (1500 RPM)

5,5	GM2EL 132 S 4a	1465	11,2	35,9	0,81	87,7	87,8	87,2	7	2,3	2,8	0,9	3,5	0,021	48
7,5	GM2EL 132 M 4b	1465	15,4	48,9	0,79	88,7	88,8	88,4	7,1	2,3	2,7	0,9	3,4	0,026	56
9,2	C.GM2EL 132 M 4c	1455	19,3	60,1	0,77	89,8	89,8	89,4	6,6	2,2	2,6	0,9	3,1	0,031	58
11	C.GM2EL 132 M 4d	1460	21,8	72	0,81	89,8	89,9	89,3	6,8	2,2	2,4	0,8	3	0,039	61
11	GM2EL 160 M 4a	1460	21,6	72	0,82	89,8	89,9	89,3	6,8	2,2	2,4	0,8	3	0,061	113
15	GM2EL 160 L 4b	1470	29,4	97,4	0,81	90,6	90,7	89,7	7,4	2,4	2,8	0,9	3,2	0,082	132
18,5	C.GM2EL 160 L 4c	1470	35,0	120,2	0,84	91,2	91,2	90,4	7,7	2,5	3,2	1	3,4	0,1	151
18,5	GM2EL 180 M 4a	1470	34,5	120,2	0,85	91,2	91,4	90,4	7,7	2,5	3,2	1	3,4	0,13	165
22	GM2EL 180 L 4b	1470	42,5	142,9	0,82	91,6	91,6	90,6	8,3	2,7	2,7	0,9	3,8	0,15	180
30	C.GM2EL 180 L 4c	1465	55	195,6	0,85	92,3	92,3	92,1	7,8	2,5	2,8	0,9	2,8	0,21	215
30	GM2EL 200 L 4a	1470	53,52	194,9	0,88	92,3	92,3	92,1	7,8	2,5	2,8	0,9	2,8	0,227	232
37	C.GM2EL 200 L 4b	1470	67,0	240,4	0,86	92,7	92,7	92,2	7,2	2,3	3	1	3	0,28	273
37	GM2EL 225 S 4a	1470	67,0	240,4	0,86	92,7	92,7	92,2	7,2	2,3	3	1	3	0,3	355
45	GM2EL 225 M 4b	1470	80,0	292,3	0,87	93,1	93,1	92,4	7,3	2,4	3	1	3	0,36	375
55	C.GM2EL 225 M 4c	1475	96,0	356,1	0,88	93,5	93,5	93,2	7,6	2,5	3,1	1	2,9	0,72	405

6 poles (1000 RPM)

3	GM2EL 132 S 6a	960	7,1	29,8	0,73	83,3	83,2	80,4	4,6	1,5	1,8	0,6	2,3	0,019	50
4	GM2EL 132 M 6b	960	9,3	39,8	0,73	84,6	84,5	81,6	4,7	1,5	2	0,6	2,5	0,024	60
5,5	GM2EL 132 M 6c	960	12,7	54,7	0,73	86,0	86,0	83,1	4,9	1,6	2,2	0,7	2,6	0,032	70
7,5	GM2EL 160 M 6a	975	16,0	73,5	0,78	87,2	87,2	84,5	6,3	2	2,6	0,8	3,5	0,076	105
11	GM2EL 160 L 6b	970	22,5	108,3	0,80	88,7	88,7	85,7	6,2	2	3	1	3	0,109	133
15	GM2EL 180 L 6a	965	29,0	148,4	0,83	89,7	89,7	86,8	6,5	2,1	2,4	0,8	3	0,2	186
18,5	GM2EL 200 L 6a	980	37,5	180,3	0,79	90,4	90,4	87,7	7,2	2,3	2,3	0,7	3,2	0,234	203
22	GM2EL 200 L 6b	980	43,4	214,4	0,80	90,9	90,9	88,4	6,7	2,3	2,3	0,7	2,8	0,283	231
30	GM2EL 225 M 6a														

OPERATIONAL CHARACTERISTICS

3 Phase, 400 V, 50 Hz | Type of Operation: S1 (Continuous Operation)

Protection Degree: IP 55 | Insulation Class F (155°C) | Heat Increase Limit: B (80K)

New Series Motors

ALUMINUM FRAME

IE3

Nominal Power	Type	At Nominal Power							At Start-up				Tilting Moment Ratio	Moment of Inertia	Approx. Weight
		Speed	Current	Torque	Power Coefficient Cos φ	Efficiency η			Current Ratio		Torque Ratio				
						4/4	3/4	1/2	Direct	Y/Δ	Direct	Y/Δ			
kW	RPM	A	Nm												

2 poles (3000 RPM)

0,75	AGM3EL 80 M2a	2880	1,60	2,5	0,84	80,7	80,6	78,5	6,2	-	2,5	-	3,2	0,00066	8,8
1,1	AGM3EL 80 M2b	2900	2,30	3,6	0,83	82,7	82,5	80,6	5,9	-	2,6	-	3,7	0,0008	10,4
1,5	AGM3EL 90 S2a	2900	3,30	4,9	0,78	84,2	84,0	82,5	6,3	-	3,1	-	3,7	0,0014	13,5
2,2	AGM3EL 90 L2b	2900	4,45	7,2	0,83	85,9	85,4	85,0	6,6	-	2,9	-	3,5	0,0017	16
3	AGM3EL 100 L2a	2900	5,80	9,9	0,86	87,1	86,9	85,3	7,6	-	3,4	-	4	0,0031	22
4	AGM3EL 112 M2a	2920	7,40	13,1	0,89	88,1	88,0	87,2	7,2	2,3	2,8	0,9	3,5	0,0048	24,1
5,5	AGM3EL 132 S2a	2925	9,70	18	0,92	89,2	89,0	87,4	7,2	2,3	2,1	0,7	2,8	0,015	51
7,5	AGM3EL 132 M2b	2930	12,9	24,4	0,93	90,1	90,1	89,5	7,8	2,5	2	0,6	2,9	0,021	63
9,2	C.AGM3EL 132 M2c	2930	16,1	30,0	0,92	90,1	90,1	89,5	8,0	2,7	2,2	0,7	3,3	0,026	74
11	C.AGM3EL 132 M2d	2930	19	35,9	0,92	91,2	91,2	89,8	8,3	2,8	2,6	0,9	3,4	0,030	79
11	AGM3EL 160 M2a	2955	19,0	35,5	0,92	91,2	91,2	90,4	7,1	2,3	2	0,6	2,6	0,031	90
15	AGM3EL 160 M2b	2955	25,7	48,5	0,92	91,9	91,8	91,2	7,9	2,5	2,2	0,7	2,9	0,041	105
18,5	AGM3EL 160 L2c	2960	31,4	59,7	0,92	92,4	92,5	92,0	8,1	2,6	2,2	0,7	3,1	0,049	122
22	AGM3EL 180 M2a	2960	36,9	71	0,93	92,7	92,6	92,2	8,5	2,7	2,9	0,9	3,4	0,091	157
30	AGM3EL 200 L2a	2980	52,0	96,1	0,89	93,3	93,3	92,8	8,5	2,7	2,8	0,9	3,5	0,15	161
37	AGM3EL 200 L2b	2980	63,0	118,6	0,90	93,7	93,7	93,1	8,3	2,7	2,8	0,9	3,1	0,17	191

4 poles (1500 RPM)

0,75	AGM3EL 80 H4b	1425	1,85	5,0	0,71	82,5	82,5	80,8	5	-	2,5	-	2,8	0,0017	12,6
1,1	AGM3EL 90 S4a	1440	2,60	7,3	0,73	84,1	84,1	82,8	5,1	-	2,5	-	3	0,0025	13,8
1,5	AGM3EL 90 H4b	1435	3,30	10	0,77	85,3	85,3	84,0	6,5	-	3	-	3,4	0,0033	17
2,2	AGM3EL 100 L4a	1445	5,00	14,5	0,73	86,7	86,8	85,0	5,9	-	2,7	-	3,4	0,0052	26,3
3	AGM3EL 100 H4b	1445	6,60	19,8	0,75	87,7	87,8	86,1	6,4	-	3,2	-	3,8	0,0068	29,2
4	AGM3EL 112 M4a	1450	8,00	26,3	0,81	88,6	88,5	88,0	6,6	2,1	3	1	3,3	0,012	36
5,5	AGM3EL 132 S4a	1450	11,0	36,2	0,81	89,6	89,6	88,8	7	2,3	2,7	0,9	3,3	0,026	38,4
7,5	AGM3EL 132 M4b	1470	15,4	48,7	0,78	90,4	90,5	89,6	7,5	2,4	3	1	3,6	0,032	49,3
9,2	C.AGM3EL 132 M4c	1460	18,3	60,1	0,80	90,4	90,5	90,4	6,6	2,2	2,6	0,9	3,1	0,042	56,3
11	AGM3EL 160 M4a	1470	21,1	71,5	0,82	91,4	91,3	91,0	6,1	2	1,9	0,6	2,6	0,076	92
15	AGM3EL 160 L4b	1475	28,5	97,1	0,82	92,1	92,0	91,8	6,7	2,2	2	0,6	2,9	0,102	115
18,5	AGM3EL 180 M4a	1475	34,0	119,8	0,85	92,6	92,6	91,6	7,9	2,5	2,5	0,8	2,8	0,177	160
22	AGM3EL 180 L4b	1475	39,4	142,4	0,87	93,0	92,8	92,0	7,5	2,4	2,4	0,8	2,8	0,192	176
30	AGM3EL 200 L4a	1475	52,8	194,2	0,88	93,6	93,5	93,0	8,2	2,6	2,4	0,8	3	0,264	225

6 poles (1000 RPM)

0,75	AGM3EL 90 S6a	950	2,00	7,5	0,69	78,9	78,9	76,9	4	-	2	-	2,3	0,0038	13,3
1,1	AGM3EL 90 L6b	950	2,90	11,1	0,68	81,0	81,0	78,3	4	-	2	-	2,4	0,0051	15,2
1,5	AGM3EL 100 L6a	955	3,60	15	0,73	82,5	82,3	80,3	5,1	-	2,4	-	3	0,011	22,8
2,2	AGM3EL 112 M6a	960	5,30	21,9	0,71	84,3	84,1	82,1	5,8	-	2,6	-	3,2	0,016	30
3	AGM3EL 132 S6a	960	7,10	29,8	0,73	83,3	83,2	85,2	5,4	1,7	2,1	0,7	2,9	0,023	39
4	AGM3EL 132 M6b	975	10,2	39,2	0,65	86,8	86,7	86,4	5,6	1,8	2,5	0,8	3,1	0,028	49
5,5	AGM3EL 132 M6c	975	13,7	53,9	0,66	88,0	87,8	87,5	5,9	1,9	2,6	0,8	3,3	0,036	63
7,5	AGM3EL 160 M6a	970	16,2	73,8	0,75	89,1	89,0	88,1	6,7	2,2	2,6	0,8	3,4	0,091	96
11	AGM3EL 160 L6b	975	22,7	107,7	0,77	90,3	90,3	89,0	7,1	2,3	2,5	0,8	3,4	0,13	122
15	AGM3EL 180 L6a	975	28,7	146,9	0,83	91,2	91,2	90,8	8	2,6	2,4	0,8	3,2	0,216	162
18,5	AGM3EL 200 L6a	980	36,8	180,3	0,79	91,7	91,6	91,3	7,9	2,5	2,9	0,9	3,3	0,289	188
22	AGM3EL 200 L6b	980	42,2	214,4	0,82	92,2	92,0	91,7	7,4	2,4	2,9	0,9	2,9	0,344	262

Efficiency values are calculated by the indirect measurement method in accordance with IEC 60034-2-1: 2014 standard. Additional losses are assessed based on test results performed at variable load values.

OPERATIONAL CHARACTERISTICS

3 Phase, 400 V, 50 Hz | Type of Operation: S1 (Continuous Operation)

Protection Degree: IP 55 | Insulation Class F (155°C) | Heat Increase Limit: B (80K)

New Series Motors

IE3

CAST IRON FRAME

Nominal Power	Type	At Nominal Power							At Start-up				Tilting Moment Ratio	Moment of Inertia	Approx. Weight
		Speed	Current	Torque	Power Coefficient Cos φ	Efficiency η			Current Ratio		Torque Ratio				
						4/4	3/4	1/2	Direct	Y/Δ	Direct	Y/Δ			
kW	RPM	A	Nm												

2 poles (3000 RPM)

5,5	GM3EL 132 S2a	2925	9,70	18	0,92	89,2	89,0	87,4	7,2	2,3	2,1	0,7	2,8	0,015	66,5
7,5	GM3EL 132 M2b	2930	12,9	24,4	0,93	90,1	90,1	89,5	7,8	2,5	2	0,6	2,9	0,021	80,4
9,2	C.GM3EL 132 M2c	2930	16,1	30,0	0,92	90,1	90,1	89,5	8,0	2,7	2,2	0,7	3,3	0,026	74
11	C.GM3EL 132 M2d	2930	19	35,9	0,92	91,2	91,2	89,8	8,3	2,8	2,6	0,9	3,4	0,030	79
11	GM3EL 160 M2a	2955	19,0	35,5	0,92	91,2	91,2	90,4	7,1	2,3	2	0,6	2,6	0,031	113
15	GM3EL 160 M2b	2955	25,7	48,5	0,92	91,9	91,8	91,2	7,9	2,5	2,2	0,7	2,9	0,041	128
18,5	GM3EL 160 L2c	2960	31,4	59,7	0,92	92,4	92,5	92,0	8,1	2,6	2,2	0,7	3,1	0,049	145
22	GM3EL 180 M2a	2960	36,9	71	0,93	92,7	92,6	92,2	8,5	2,7	2,9	0,9	3,4	0,091	193
30	GM3EL 200 L2a	2980	52,0	96,1	0,89	93,3	93,3	92,8	8,5	2,7	2,9	0,9	3,5	0,15	210
37	GM3EL 200 L2b	2980	63,0	118,6	0,90	93,7	93,7	93,1	8,3	2,7	2,8	0,9	3,1	0,17	240
45	GM3EL 225 M2a	2980	77,0	144,2	0,90	94,0	94,1	93,0	8,7	2,8	2,7	0,9	3,1	0,26	400

4 poles (1500 RPM)

5,5	GM3EL 132 S4a	1450	11,0	36,2	0,81	89,6	89,6	88,8	7	2,3	2,7	0,9	3,3	0,026	48
7,5	GM3EL 132 M4b	1470	15,4	48,7	0,78	90,4	90,5	89,6	7,5	2,4	3	1	3,6	0,032	56
9,2	C.GM3EL 132 M4c	1460	18,3	60,1	0,80	90,4	90,5	90,4	6,6	2,2	2,6	0,9	3,1	0,042	63
11	GM3EL 160 M4a	1470	21,1	71,5	0,82	91,4	91,3	91,0	6,1	2	1,9	0,6	2,6	0,076	124
15	GM3EL 160 L4b	1475	28,5	97,1	0,82	92,1	92,0	91,8	6,7	2,2	2	0,6	2,9	0,102	151
18,5	GM3EL 180 M4a	1475	34,0	119,8	0,85	92,6	92,6	91,6	7,9	2,5	2,5	0,8	2,8	0,177	194
22	GM3EL 180 L4b	1475	39,4	142,4	0,87	93,0	92,8	92,0	7,5	2,4	2,4	0,8	2,8	0,192	215
30	GM3EL 200 L4a	1475	52,8	194,2	0,88	93,6	93,5	93,0	8,2	2,6	2,4	0,8	3	0,264	273
37	GM3EL 225 S4a	1475	67,0	239,6	0,85	93,9	93,9	93,5	7,5	2,4	3,1	1	3,3	0,36	350
45	GM3EL 225 M4b	1475	80,0	291,4	0,86	94,2	94,2	93,4	7,4	2,4	3	1	3,1	0,44	380

6 poles (1000 RPM)

3	GM3EL 132 S6a	970	7,3	29,5	0,69	85,6	85,6	85,2	5,4	1,7	2,1	0,7	2,9	0,023	53
4	GM3EL 132 M6b	975	10,2	39,2	0,65	86,8	86,7	86,4	5,6	1,8	2,5	0,8	3,1	0,028	62
5,5	GM3EL 132 M6c	975	13,7	53,9	0,66	88,0	87,8	87,5	5,9	1,9	2,6	0,8	3,3	0,036	71
7,5	GM3EL 160 M6a	970	16,2	73,8	0,75	89,1	89,0	88,1	6,7	2,2	2,6	0,8	3,4	0,091	119
11	GM3EL 160 L6b	975	22,7	107,7	0,77	90,3	90,3	89,0	7,1	2,3	2,5	0,8	3,4	0,13	145
15	GM3EL 180 L6a	975	28,7	146,9	0,83	91,2	91,2	90,8	8	2,6	2,4	0,8	3,2	0,216	201
18,5	GM3EL 200 L6a	980	36,8	180,3	0,79	91,7	91,6	91,3	7,9	2,5	2,9	0,9	3,3	0,289	236
22															

NEW SERIES PREMIUM EFFICIENCY MOTORS

New Series Motors

IE-

OPERATIONAL CHARACTERISTICS

3 Phase, 400 V, 50 Hz | Type of Operation: S1 (Continuous Operation)

Protection Degree: IP 55 | Insulation Class F (155°C) | Heat Increase Limit: B (80K)

ALUMINUM FRAME

4 poles (1500 RPM)

Nominal Power	Type	At Nominal Power						At Start-up				Tilting Moment Ratio	Moment of Inertia	Approx. Weight	
		Speed	Current	Torque	Power Coefficient Cos φ	Efficiency η			Current Ratio		Torque Ratio				
		RPM	A	Nm		4/4	3/4	1/2	Direct	Y/Δ	Direct				Y/Δ
0,55	C.AGMEL 71 M 4c	1385	1,60	3,8	0,75	68,6	68,6	67,6	3,4	-	1,9	-	2,1	0,00062	6,4
0,55	AGMEL 80 M 4a	1365	1,60	3,8	0,64	77,1	77,1	75,6	3,5	-	1,9	-	2	0,00083	7,7



NEW SERIES MOTORS

Efficiency values are calculated by the indirect measurement method in accordance with IEC 60034-2-1: 2014 standard. Additional losses are assessed based on test results performed at variable load values.

SPARE PARTS

New Series Motors

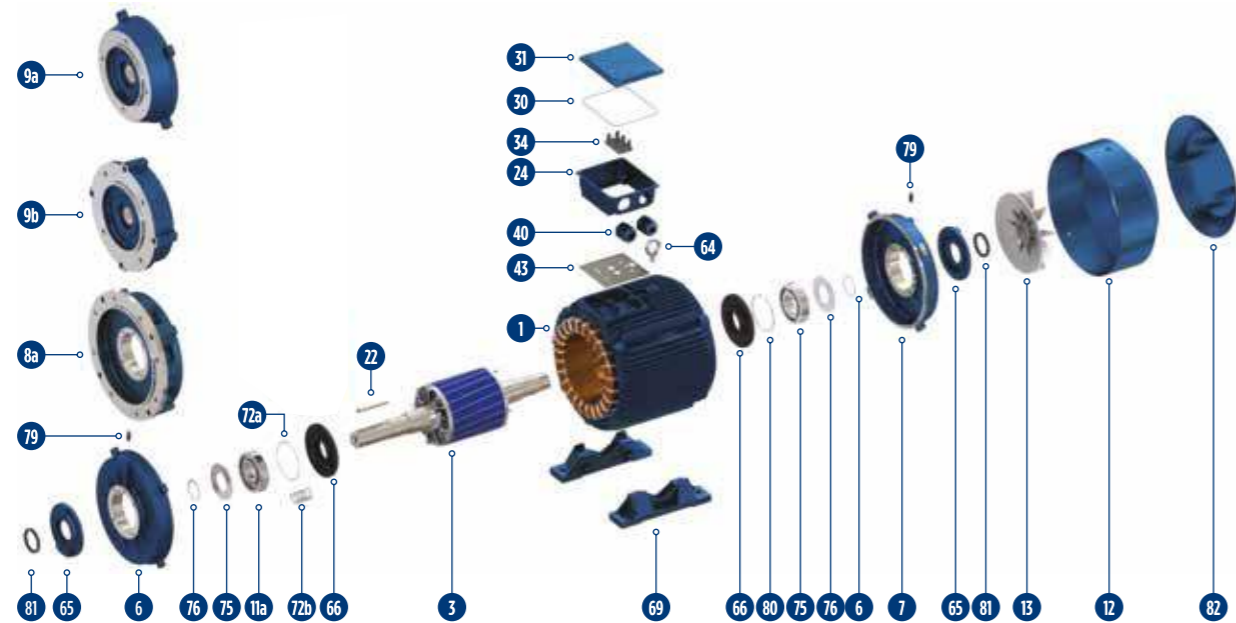

- 1 Stator with Complete Windings: Varnished and installed to the body
- 3 Complete Rotor: With balanced, shaft, machined (excluding keys)
- 6 Front cover
- 7 Rear cover
- 8a Flange (Form A - "FF") - Flange number must be specified
- 9a Flange (Form C - "FT") - Flange number must be specified
- 9b Flange (Form C - "FT", Large type) - Flange number must be specified
- 11a Front bearing (Ball or Cylindrical Roller)
- 11b Rear bearing
- 12 Fan housing bowl (63..450)
- 13 Cooling fan (63.450)
- 22 Shaft end key
- 24 End terminal box
- 30 Seal (Between terminal box and cover)
- 31 Terminal box cover
- 34 End plate - Terminal (including bridge, nuts and washers)
- 40 Cable entry gland
- 43 Seal (Between end terminal box and motor frame)
- 64 Lifting eye (200..450)
- 65 Bearing holder outer cover (for motors with lubrication nipple)
- 66 Bearing holder inner cover (for motors with lubrication nipple)
- 69 Attachable Feet Housings
- 72a Coil Spring (56...280)
- 72b Coil Spring (315..450)
- 75 Oil retaining disc (for motors with lubrication nipple)
- 76 Outer snap ring; For fixing the bearing and oil holding disc
- 79 (For motors with lubrication nipple at the front and rear, 160. 280 at the rear)
- 80 Inner snap ring For fixing the rear bearing on the cover (160..280)
- 81 Rubber dust seal (V-ring) or optional oil seal
- 82 Canopy

MOTORS WITH FLANGE (Form A – B5)

New Series Motors

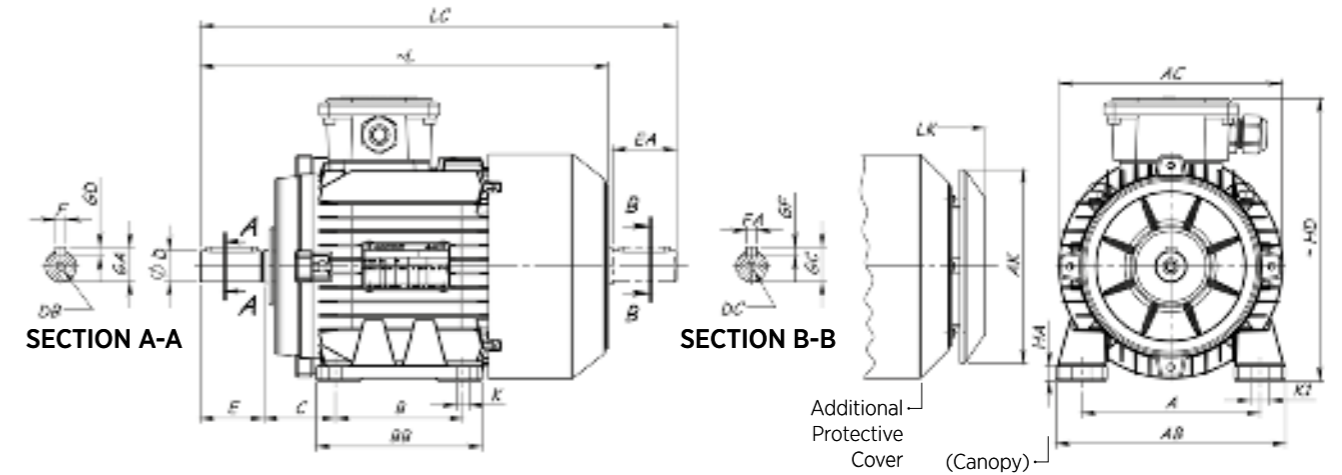

ALUMINUM FRAME

Sizes of foot mounted motor: Frame Forms B3, B6, B8, B15, V5, V6

Frame Size	No of Poles	H	HD	HA	A	AA	AB	ACØ	AKØ	K	K1	B	B'	BA	BA'	BB	L	LC	LK	C	E EA	DB DC	DØ-DAØ	GA GC	FxGD FAXGF	
71	M	2-4-6-8	71	182	10	112	31	140	138	116	7	11	90	-	26,5	-	108	260	295	289	45	30	M5	14	16	5x5
80	M	2-4-6-8	80	197	10	125	33,5	160	156	151	10	15	100	-	32,5	-	125	306	351	337	50	40	M6	19	21,5	6x6
	333																	376	360							
90	S	2-4-6-8	90	222	12	140	40	180	176	151	10	15	100	125	35	60	155	326	379	355	56	50	M8	24	27	8x7
	361																	414	390							
100	L	2-4-6-8	100	250	13	160	39	200	195	189	12	18	140	-	39	-	175	396,5	464,5	438	63	60	M10	28	31	8x7
	432																	495	469							
112	M	2-4-6-8	112	265	13	190	52	230	220	189	12	18	140	-	39	-	175	403,5	473	447	70	60	M10	28	31	8x7
	438,5																	495	469							
132	S	2-4-6-8	132	320	15	216	51	260	262	239	12	18	140	-	55	-	180	476,5	569,5	520,5	89	80	M12	38	41	10x8
	178												218					521,5	614,5	565,5						
160	M	2-4-6-8	160	400	22	254	63	312	315	303	15	19	210	-	70	-	260	629,5	745,5	686,5	108	110	M16	42	45	12x8
	254												304					674,5	790,5	731,5						
180	M	2-4-6-8	180	440	24	279	74	354	354	303	15	19	241	-	75	-	291	686	802	743	121	110	M16	48	51,5	14x9
	279												329					723	839	780						
200	L	2-4-6-8	200	500	26	318	81	398	394	370	19	24	305	-	80	-	365	819	935	875	133	110	M20	55	59	16x10

CAST IRON FRAME

Sizes of foot mounted motor: Frame Forms B3, B6, B7, B8, B15, V5, V6

Frame Size	No of Poles	H	HD	HA	A	AA	AB	ACØ	AKØ	K	B	B'	BA	BA'	BB	L	LC	LK	C	E EA	DB DC	DØ-DAØ	GA GC	FxGD FAXGF
132	S	2-4-6-8	132	340	15	216	50	260	262	239	12	140	50	-	180	476,5	572	523	89	80	M12	38	41	10x8
	178											218				521,5	617	568						
160	M	2-4-6-8	160	400	22	254	63	312	315	303	15	210	62,3	-	260	629,5	745,5	686,5	108	110	M16	42	45	12x8
	254											70				304	674,5	790,5						
180	M	2-4-6-8	180	440	24	279	74	354	354	303	15	241	60	-	291	686	802	743	121	110	M16	48	51,5	14x9
	279											70				329	723	839						
200	L	2-4-6-8	200	500	26	318	81	398	394	370	19	305	72,5	-	355	819	937	875	133	110	M20	55	59	16x10
225	S	2	225	548	30	356	82	438	440	370	19	286	311	80	100	365	762	940	848	149	M20	55	64	18x11
		4-6-8														792	1033	881						
	2	855														1033	881							
	4-6-8	885														1033	881							

FOOT-MOUNTED MOTORS AND FLANGE (FORM C - B35)

New Series Motors

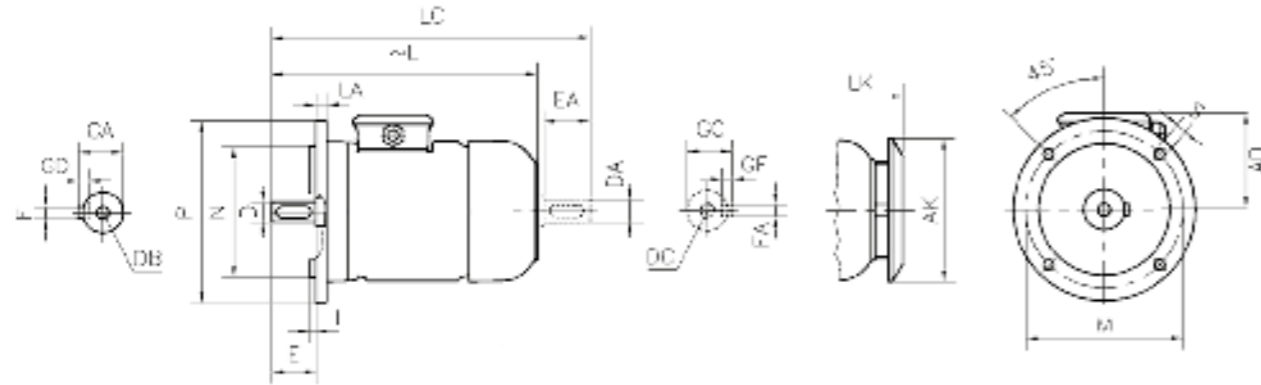

FOOT-MOUNTED MOTORS AND FLANGE (FORM C - B35)

New Series Motors

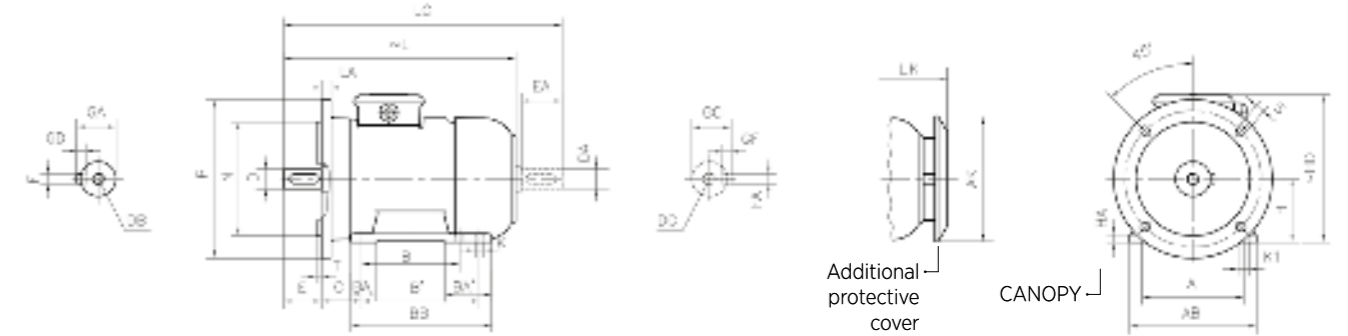

Note: The spindle collar and flange seating surface are in the same plane.

ALUMINUM FRAME

Sizes of motor with flange: (Flange form A - DIN EN 50 347), B5, V1, V3 frame forms

Frame Size	Flang No	M Ø	N Ø	P Ø	Fixing Hole		T	LA	AD	AK Ø	L	LC	LK	E EA	DB DC	DØ DAØ	GA GC	FxGD FxG	Flange Type
					Nr.	S Ø													
71 M	FF 130	130	110	160	4	10	3,5	10	110	116	260	295	289	30	M5	14	16	5x5	Aluminum
80 M	FF 165	165	130	200	4	12	3,5	10	117	151	308	351	337	40	M6	19	21,5	6x6	Aluminum
											333	376	362						
90 S	FF 165	165	130	200	4	12	3,5	10	132	151	326	379	355	50	M8	24	27	8x7	Aluminum
											361	414	384						
100 L	FF 215	215	180	250	4	14,5	4	15	141	189	401,5	464,5	438,5	60	M10	28	31	8x7	Aluminum
											432	495	469						
112 M	FF 215	215	180	250	4	14,5	4	15	144	189	403,5	473	447	60	M10	28	31	8x7	Aluminum
											438,5	495	469						
132 S	FF 265	265	230	300	4	14,5	4	20	175	239	476,5	569,5	523	80	M12	38	41	10x8	Aluminum
											521,5	614,5	568						
160 M	FF 300	300	250	350	4	18,5	5	20	230	303	629,5	745,5	686,5	110	M16	42	45	12x8	Cast Iron
											674,5	790,5	731,5						
180 M	FF 300	300	250	350	4	18,5	5	20	253	-	686	802	743	110	M16	48	51,5	14x9	Cast Iron
											723	839	780						
200 L	FF 350	350	300	400	4	18,5	5	20	289	-	819	935	875	110	M20	55	59	16x10	Cast Iron

ALUMINUM FRAME

Sizes of foot mounted motors and flange: (Flange form A - DIN EN 50 347 B35 frame forms)

Frame Size	H	HD	HA	A	AB	AKØ	K	K1	B	B'	BA	BA'	BB	Flange Nr.	MØ	NØ	PØ	No	SØ	T	LA	L	LC	LK	C	E EA	DB DC	DØ DAØ	GA GC	FxGD FxG
80 M	80	197	10	125	33,5	151	10	15	100	-	32,5	-	125	FF 165	165	130	200	4	12	3,5	12	308	351	337	50	40	M6	19	21,5	6x6
																						333	376	362						
90 S	90	222	12	140	40	151	10	15	100	-	35	-	130	FF 165	165	130	200	4	12	3,5	12	326	389	355	56	50	M8	24	27	8x7
																						361	414	390						
100 L	100	250	13	160	39	189	12	18	140	-	39	-	175	FF 215	215	180	250	4	14,5	4	15	396,5	434,5	438	60	60	M10	28	31	8x7
																						432	495	469						
112 M	112	265	13	190	52	189	12	18	140	-	39	-	175	FF 215	215	180	250	4	14,5	4	15	403,5	473	447	70	60	M10	28	31	8x7
																						438,5	495	469						
132 S	132	320	15	216	51	239	12	-	140	-	55	-	180	FF 265	265	230	300	4	14,5	4	20	476,5	569,5	520,5	89	80	M12	38	41	10x8
																						531,5	614,5	565,5						
160 M	160	400	22	254	63	303	15	19	210	-	70	-	260	FF 300	300	250	350	4	18,5	4	20	629,5	745,5	686,5	108	110	M16	42	45	12x8
																						674,5	790,5	731,5						
180 M	180	440	24	279	74	303	15	19	241	-	75	-	291	FF 300	300	250	350	4	18,5	5	20	686	802	743	121	110	M16	48	51,5	14x9
																						723	839	780						
200 L	200	500	26	318	81	370	19	24	305	-	80	-	365	FF 350	350	300	400	4	18,5	5	20	819	935	875	133	110	M20	55	59	16x10

CAST IRON FRAME

Sizes of motor with flange: (Flange form A - DIN EN 50 347), B5, V1, V3 frame forms

Frame Size	No of Poles	M Ø	N Ø	P Ø	Fixing Hole		T	LA	AD	AK Ø	L	LC	LK	E EA	DB DC	DØ DAØ	GA GC	FxGD FxG	Flange Type				
					Nr.	S Ø																	
132 S	2-4-6-8	265	230	300	4	14,5	4	20	208	239	486	572	523	80	M12	38	41	10x8	Cast Iron				
											531	617	568										
160 M	2-4-6-8	300	250	350	4	18,5	4	20	241	303	629,5	745,5	686,5	110	M16	42	45	12x8	Cast Iron				
											674,5	790,5	731,5										
180 M	2-4-6-8	300	250	350	4	18,5	5	20	262	-	686	802	743	110	M16	48	51,5	14x9	Cast Iron				
											723	839	780										
200 L	2-4-6-8	350	300	400	4	18,5	5	20	300	-	819	935	875	110	M20	55	59	16x10	Cast Iron				
225 S	2	400	350	450	8	18,5	5	20	323	370	762	938	846	110	M20	55	59	16x10	Cast Iron				
	4-6-8										792	940	849										
	2										855	1001	939							110	55	59	16x10
	4-6-8										885	1033	941										

CAST IRON FRAME

Sizes of foot mounted motors and flange: (Flange form A - DIN EN 347) B35 frame forms

Frame Size	No of Poles	H	HD	HA	A	AB	AKØ	KQ	K1	B	B'	BA	BA'	BB	Flange Nr.	MØ	NØ	PØ	No	SQ	T	LA	L	LC	LK	C	E EA	DB DC	DØ DAØ	GA GC	FxGD FxG																													
																																132 S	2-4-6-8	132	340	15	216	260	239	12	-	140	-	50	-	180	FF 265	265	230	300	4	14,5	4	20	476,5	572	523	89	80	M12
M	2-4-6-8	160	400	22	254	312	303	15	-	210	-	62,3	-	260	FF 300	300	250	350	4	18,5	4	20	629,5	745,5	686,5																																			
160 M	2-4-6-8	160	400	22	254	312	303	15	-	254	-	70	-	304	FF 300	300	250	350	4	18,5	4	20	629,5	745,5	686,5	108	110	M16	42	45	12x8																													
																							674,5	790,5	731,5																																			
180 M	2-4-6-8	180	440	24	279	354	303	15	-	241	-	60	-	291	FF 300	300	250	350	4	18,5	5	20	686	802	743	121	110	M16	48	51,5	14x9																													
																							723	839	780																																			
200 L	2-4-6-8	200	500	26	319	398	370	19	-	305	-	72,5	-	355	FF 350	350	300	400	4	18,5	5	20	819	935	875	133	110	M20	55	59	16x10																													
																							885	1033	941																																			
																							S	2	225							548	30	356	438	370	19	-	286	311	80	100	365	FF 400	400	350	450	4	18,5	5	20	762	880	941	149	110	M20	55	59	16x10
																							4-6-8	792																												940	849							
M	2	855	973	911	140	60	64	18x11																																																				
4-6-8	885	1033	941																																																									

SPECIAL
SERIES

”
SMOKE EXTRACTION
MOTORS
“

SMOKE EXTRACTION MOTORS



3 Phase, 400 V, 50 Hz | Type of Operation: S1 (Continuous Operation)
 Protection Degree: IP 55 | Insulation Class F (155°C) | Heat Increase Limit: B (80K)

Smoke extraction motors are certified following the tests conducted according to the TS EN 12101-3 Standard. The tests were carried out in Applus + and Efectis Test Laboratory. As a result of the tests, Gamak Smoke Extraction Motors have been certified in conformance with 300°C 2 hours operation. They are used to create a smoke-free area so that extinguishing and rescue work can be done easily in case of fire, while preventing any damage to the living beings in the environment. Smoke extraction motors work in conjunction with jet fans for both emergencies during fire and ventilation needs in indoor areas. They are designed for S1 Continuous + S2 Short-term (Emergency) operation.

There are 2 types of motors used in these ventilators:

S2 : Short-term EMERGENCY operation - Operation for a predetermined time and temperature in case of fire.
 S1 + S2 : Continuous operation + short term EMERGENCY operation - Continuous operation is for ventilation purposes, e.g. removal of exhaust gases in road tunnels.

In case of continuous operation request, smoke motors can be manufactured with high efficiency.

How long and at what temperature the motors will be operated in EMERGENCY operation must be specified in advance by the user. A classification is made in the standards according to the temperatures and operating times in the table below.

Class	Temperature (°C)	Shortest running time (min)
F200	200	120
F300	300	60
F400	400	120
F600	600	60
F842	842	30
Special class	To be specified by the user	To be specified by the user

For example, Class F300 motors are manufactured to work at 300°C for 1 hour. The working temperature and duration of the Special Class specified in the table in the standards are determined by the user. Accordingly, a smoke evacuation motor suitable for working at different temperatures and times is manufactured.

Mechanical Properties:

- The motors can be manufactured as TEFC - Fully enclosed fan cooled or TEAO - Fully closed cooled with air passing over. In applications where the motor is directly coupled to the fan, it is cooled by the air (TEAO) passing over the motor, and for volute type fans, the motor must be cooled (TEFC). In uncooled motors, in order not to block the air passing over the motor, the terminal box is not installed and the cables are laid directly for connection.
- All the motor frames are made of cast iron.
- All motors are manufactured in Class H insulation, in accordance with Class B temperature rise.
- Motors can be manufactured with thermistors, but the thermistors must be disabled during EMERGENCY operation.

Note: The motor used once in the EMERGENCY operation must be replaced.
 The features of standard smoke motors also include pad mounted motors.

Nominal Power kW	Type	At Nominal Power						At Start-up				Tilting Moment Ratio	Moment of Inertia	Approx. Weight	
		Speed RPM	Current A	Torque Nm	Power Coefficient Cos φ	Efficiency η			Current Ratio		Torque Ratio				
						4/4	3/4	1/2	Direct	Y/Δ	Direct	Y/Δ			

2 poles (3000 RPM)

0,75	GM2ED 80 M 2a	2860	1,7	2,5	0,82	77,4	77,4	74,6	6,2	-	2,5	-	3	0,00066	14
1,1	GM2ED 80 M 2b	2880	2,3	3,6	0,87	79,6	79,6	77,9	6,3	-	2,7	-	3	0,0008	15,6
1,5	GM2ED 90 S 2a	2880	3,3	5	0,81	81,3	81,3	79,8	6,3	-	2,3	-	3	0,0014	19,8
2,2	GM2ED 90 L 2b	2870	4,5	7,3	0,85	83,2	83,2	81,9	6,6	-	2,6	-	3,1	0,0017	22,3
3	GM2ED 100 L 2a	2880	5,9	9,9	0,89	84,6	84,6	84,1	6	-	2,5	-	3	0,0031	30,9
4	GM2ED 112 M 2a	2880	7,9	13,3	0,85	85,8	85,8	85	7,2	2,4	2,8	0,9	3,5	0,0048	35
5,5	GM2ED 132 S 2a	2900	10,3	18,1	0,89	87	87	86,5	6,6	2,2	2,5	0,8	3,1	0,012	51
7,5	GM2ED 132 S 2b	2910	13,6	24,6	0,9	88,1	88,1	87,9	7,2	2,4	3	1	3,4	0,014	56
11	GM2ED 160 M 2a	2945	19,5	35,7	0,91	89,4	89,4	88,6	7,7	2,6	3,4	1,1	3,6	0,040	105
15	GM2ED 160 M 2b	2945	28,3	48,6	0,85	90,3	90,3	89,7	7,5	2,5	3	1	3,5	0,041	113
18,5	GM2ED 160 L 2c	2950	32,3	59,9	0,91	90,9	90,8	90,1	7,7	2,6	2,5	0,8	3	0,051	135
22	GM2ED 180 M 2a	2950	38,3	71,2	0,91	91,3	91,3	90,8	8,2	2,7	3	1	3,5	0,075	170
30	GM2ED 200 L 2a	2970	52	96,5	0,91	92	92	91,2	8,3	2,8	2,7	0,9	3	0,13	210
37	GM2ED 200 L 2b	2970	65	119	0,89	92,5	92,5	91,7	8,3	2,8	2,7	0,9	3	0,15	240
55	GM2ED 250 M 2a	2980	94	176,3	0,91	93,2	93,7	92,2	7,6	2,5	2,6	0,9	2,7	0,41	445
75	GM2ED 280 S 2a	2980	128	240,4	0,91	93,8	94	92,5	7	2,3	2,4	0,8	2,5	0,62	585
90	GM2ED 280 M 2b	2980	152	288,4	0,91	94,1	94,1	92,7	8,5	2,8	2,7	0,9	3	0,74	645
110	GM2ED 315 S 2a	2980	192	352,5	0,88	94,3	94,3	92,8	7	2,3	2,5	0,8	3	1,2	742
132	GM2ED 315 M 2b	2980	224	423	0,9	94,6	94,5	92,9	8	2,7	2,5	0,8	3	1,4	812
160	GM2ED 315 M 2c	2980	266	512,8	0,92	94,8	94,8	93,4	7,8	2,6	2,5	0,8	3,2	1,5	912

All motors are made of cast iron.

Efficiency values are calculated by the indirect measurement method in accordance with the IEC 60034-2-1: 2014 standard. Additional losses are assessed based on test results performed at variable load values.

F300 - IE2

OPERATIONAL CHARACTERISTICS

3 Phase, 400 V, 50 Hz | Type of Operation: S1 (Continuous Operation)

Protection De-gree: IP 55 | Insulation Class F (155°C) | Heat Increase Limit: B (80K)

Nominal Power	Type	At Nominal Power							At Start-up				Tilting Moment Ratio	Moment of Inertia	Approx. Weight
		Speed	Current	Torque	Power Coefficient Cos φ	Efficiency η			Current Ratio		Torque Ratio				
kW		RPM	A	Nm		4/4	3/4	1/2	Direct	Y/Δ	Direct	Y/Δ			

4 poles (1500 RPM)

0,25	GMD 71 M 4a	1380	0,8	1,7	0,72	61,9	61,8	58,2	2,9	-	1,8	-	2,2	0,0004	8,9
0,37	GMD 71 M 4b	1390	1,15	2,5	0,68	68,1	68,1	67,1	3,7	-	2,2	-	2,5	0,00054	9,8
0,55	GMD 80 M 4a	1365	1,6	3,8	0,72	69,1	69	65,2	3,5	-	1,9	-	2	0,00083	12,7
0,75	GM2ED 80 M 4b	1410	2	5,1	0,68	79,6	79,6	77,6	5	-	2,6	-	2,8	0,0014	15,6
1,1	GM2ED 90 S 4a	1420	2,6	7,4	0,75	81,4	81,4	80,5	5,5	-	3	-	3,3	0,0025	20,7
1,5	GM2ED 90 L 4b	1430	3,5	10	0,75	82,8	82,8	81,5	5,9	-	3,3	-	3,5	0,0033	24
2,2	GM2ED 100 L 4a	1435	5	14,6	0,76	84,3	84,3	82,5	5,9	-	2,9	-	3,4	0,0052	31,6
3	GM2ED 100 L 4b	1435	6,6	20	0,77	85,5	85,7	84	6,2	-	2,9	-	3,4	0,0068	38
4	GM2ED 112 M 4a	1455	8,4	26,3	0,81	86,6	86,7	85,3	6,6	2,2	2,5	0,8	3,3	0,012	49
5,5	GM2ED 132 S 4a	1465	11,2	35,9	0,81	87,7	87,7	87,2	7	2,3	2,8	0,9	3,5	0,026	58
7,5	GM2ED 132 M 4b	1465	15,4	48,9	0,79	88,7	88,8	88,1	7,1	2,4	2,7	0,9	3,4	0,032	69
11	GM2ED 160 M 4a	1465	21,3	71,7	0,83	89,8	89,9	89,3	6,9	2,3	2,8	0,9	3,1	0,072	130
15	GM2ED 160 L 4b	1465	29,8	97,8	0,8	90,6	90,7	89,7	7,5	2,5	2,6	0,9	3,5	0,092	141
18,5	GM2ED 180 M 4a	1470	34,5	120,2	0,85	91,2	91,4	90,4	7,7	2,6	3,2	1,1	3,4	0,15	180
22	GM2ED 180 L 4b	1470	42,5	142,9	0,82	91,6	91,4	90,6	8,3	2,8	2,7	0,9	3,8	0,17	190
30	GM2ED 200 L 4a	1470	55	194,9	0,85	92,3	92,4	92,1	8	2,7	3,1	1	3,6	0,23	227
37	GM2ED 225 S 4a	1470	67	240,4	0,86	92,7	92,7	92,2	7,2	2,4	3	1	3	0,35	314
45	GM2ED 225 M 4b	1470	80	292,3	0,87	93,1	93,1	92,4	7,3	2,4	3	1	3	0,44	360
55	GM2ED 250 M 4a	1475	96,8	356,1	0,88	93,5	93,6	93,2	7,6	2,5	3,1	1	2,9	0,78	445
75	GM2ED 280 S 4a	1480	133	484	0,87	94	94,1	93,4	7	2,3	2,6	0,9	2,8	1,11	605
90	GM2ED 280 M 4b	1480	158	580,7	0,87	94,2	94,5	93,8	7,4	2,5	2,9	1	3	1,32	665
110	GM2ED 315 S 4a	1485	195	707,4	0,86	94,5	94,5	93,8	7,4	2,5	2	0,7	3	2,1	784
132	GM2ED 315 M 4b	1485	230	848,9	0,87	94,7	94,5	93,8	7,4	2,5	2,1	0,7	3	2,5	861
160	GM2ED 315 M 4c	1485	280	1029	0,87	94,9	94,9	94	7	2,3	2	0,7	2,9	2,7	882

All motors are made of cast iron.

Efficiency values are calculated by the indirect measurement method in accordance with the IEC 60034-2-1: 2014 standard. Additional losses are assessed based on test results performed at variable load values.

F300

OPERATIONAL CHARACTERISTICS

3 Phase, 400 V, 50 Hz | Type of Operation: S2 + S1 Protection Degree: IP 55 |

Insulation Class H (180°C) Heat Increase Limit: B (80K)

Load torque proportional to the square of the speed(Pump and Ventilator)

Single winding - Dahlander Connection Y/YY

Nominal Power	Type	At Nominal Power							At Start-up				Tilting Moment Ratio	Moment of Inertia	Approx. Weight
		Speed	Current	Torque	Power Coefficient Cos φ	Efficiency η			Current Ratio		Torque Ratio				
kW		RPM	A	Nm		4/4	3/4	1/2	Direct	Y/Δ	Direct	Y/Δ			

4/2 poles (1500/3000 RPM)

0,17/0,75	VGMD 80 4/2a	1400/2790	0,50/1,7	1,2/2,6	0,77/0,91	62,2/68,3	62,2/68,3	62,2/68,3	3,5/4,1	1,6/1,7	1,9/1,9	0,00053	10,3
0,25/1	VGMD 80 4/2b	1410/2810	0,70/2,2	1,7/3,4	0,75/0,98	67,1/65,4	67,1/65,4	67,1/65,4	3,3/3,6	1,4/1,6	1,7/1,9	0,00066	11,5
0,33/1,3	VGMD 90 S 4/2	1425/2860	0,90/2,8	2,2/4,3	0,74/0,87	70,1/75,2	70,1/75,2	70,1/75,2	3,7/4,4	1,6/1,8	2/1,9	0,0011	13,8
0,5/2	VGMD 90 L 4/2	1415/2835	1,2/4,2	3,4/6,7	0,78/0,88	75,0/76,2	75,0/76,2	75,0/76,2	4,5/6	2/1,8	2,4/2,5	0,0014	16,1
0,66/2,7	VGMD 100 L 4/2	1430/2845	1,5/5,2	4,4/9,1	0,81/0,95	76,0/77,2	76,0/77,2	76,0/77,2	4,9/4,7	1,7/1,9	2,3/2,1	0,0024	21,9
0,9/3,6	VGMD 112 M 4/2	1440/2870	2/7,3	6,0/12	0,83/0,89	76,1/78,3	76,1/78,3	76,1/78,3	5,5/6	1,8/2	2,6/2,5	0,0039	26
1,25/5	VGMD 132 S 4/2a	1440/2860	3/9,8	8,3/16,7	0,81/0,93	75,2/77,3	75,2/77,3	75,2/77,3	4,3/4,9	1,8/2,1	2,1/2,2	0,0090	45
1,7/6,5	VGMD 132 S 4/2b	1440/2900	3,6/12,5	11,3/21,4	0,84/0,89	79,1/82,3	79,1/82,3	79,1/82,3	5,8/6,8	2,3/2,3	2,5/2,7	0,012	52
2,5/10	VGMD 160 M 4/2a	1450/2910	5,3/19,5	16/33	0,84/0,9	79,2/80,4	79,2/80,4	79,2/80,4	5/5,3	2,1/2,5	2,2/2,7	0,026	94
3,3/13	VGMD 160 M 4/2b	1460/2930	6,7/24	22/42	0,85/0,91	82,2/84,4	82,2/84,4	82,2/84,4	6,8/8,6	2,2/2,5	2,9/3,3	0,034	105
4,4/17	VGMD 160 L 4/2	1460/2930	8,6/32	29/55	0,87/0,89	83,2/84,4	83,2/84,4	83,2/84,4	6,9/8,8	2,4/2,6	2,7/3	0,041	118
5/20	VGMD 180 M 4/2	1475/2940	10/37	32/65	0,87/0,9	81,3/85,4	81,3/85,4	81,3/85,4	6,7/7,7	2,6/2,4	2,7/2,7	0,060	150
7,5/28	VGMD 200 L 4/2a	1470/2960	15/50	49/90	0,85/0,92	83,3/86,5	83,3/86,5	83,3/86,5	6,4/7,5	2,3/2,1	2,3/2,4	0,10	215
8,5/33	VGMD 200 L 4/2b	1470/2950	16/59	55/107	0,87/0,9	86,2/88,5	86,2/88,5	86,2/88,5	6,8/7,6	2,1/1,9	2,2/2,1	0,13	235
10/40	VGMD 225 M 4/2	1470/2955	20/72	65/129	0,82/0,91	86,3/86,5	86,3/86,5	86,3/86,5	5,5/6,5	2/1,8	2,1/2,4	0,19	315
12,5/48	VGMD 250 M 4/2	1480/2965	25/86	81/155	0,81/0,9	87,3/88,5	87,3/88,5	87,3/88,5	5,7/7,5	2/2,1	2,1/2,4	0,32	385
17/66	VGMD 280 S 4/2	1480/2970	33/115	110/212	0,83/0,91	88,3/89,6	88,3/89,6	88,3/89,6	6,2/7,9	2/2,1	2,2/2,6	0,50	560
20/78	VGMD 280 M 4/2	1480/2970	38/133	129/251	0,84/0,93	88,4/89,6	88,4/89,6	88,4/89,6	6,7/8,2	2/2,1	2,3/2,7	0,62	595
25/100	VGMD 315 S 4/2	1485/2975	48/172	161/321	0,84/0,92	88,4/89,7	88,4/89,7	88,4/89,7	6,5/7,9	1,4/1,7	2,4/2,7	0,96	720
30/120	VGMD 315 M 4/2a	1490/2980	58/205	192/385	0,82/0,92	89,4/90,7	89,4/90,7	89,4/90,7	8/8,8	1,6/1,9	2,6/2,9	1,20	805
37/150	VGMD 315 M 4/2b	1490/2980	68/252	237/481	0,84/0,92	91,4/91,7	91,4/91,7	91,4/91,7	6,5/8,2	1,6/1,9	2,5/2,8	1,40	870

8/4 poles (750/1500 RPM)

0,12/0,5	VGMD 80 8/4a	680/1430	0,65/1,5	1,7/3,3	0,51/0,75	50,5/62,3	50,5/62,3	50,5/62,3	2,1/3,2	1,4/1,7	1,7/2,1	0,00083	12,8
0,18/0,75	VGMD 80 8/4b	680/1405	0,90/2	2,5/5,1	0,54/0,81	51,5/65,3	51,5/65,3	51,5/65,3	2,1/3,5	1,6/1,7	1,8/2,1	0,0011	13,9
0,25/1	VGMD 90 S 8/4	700/1410	1,2/2,8	3,4/6,8	0,51/0,69	57,4/73,2	57,4/73,2	57,4/73,2	2,7/4,6	1,6/2,1	1,9/2,4	0,0019	17,8
0,33/1,4	VGMD 90 L 8/4	690/1390	1,3/3,3	4,6/9,6	0,60/0,79	59,4/76,2	59,4/76,2	59,4/76,2	2,6/4,3	1,7/1,8	1,9/2,1	0,0024	20,8
0,5/2	VGMD 100 L 8/4a	700/1415	1,8/4,8	7/13	0,61/0,82	64,3/71,3	64,3/71,3	64,3/71,3	2,9/4,8	1,5/1,8	2,1/2,3	0,0038	27,8
0,6/2,5	VGMD 100 L 8/4b	690/1410	2/5,5	8/17	0,66/0,86	64,3/74,3	64,3/74,3	64,3/74,3	3,2/5,2	1,5/1,9	2,0/2,3	0,0050	31
1/3,8	VGMD 112 M 8/4	700/1425	3,2/8,3	14/25	0,63/0,83	70,2/78,3	70,2/78,3	70,2/78,3	3,4/5,2	1,4/2,0	2,0/2,5	0,0092	41
1,2/5	VGMD 132 S 8/4	715/1450	3,8/10,5	16/33	0,60/0,84	74,2/80,3	74,2/80,3	74,2/80,3	3,7/5,4	2,1/2,2	2,4/2,6	0,019	51
1,7/7	VGMD 132 M 8/4	710/1450	5,2/14,5	23/46	0,66/0,84	69,3/81,3	69,3/81,3	69,3/81,3	4,0/6,6	2,0/2,2	2,2/2,5	0,026	60
2,5/10	VGMD 160 M 8/4	720/1460	7,4/20	33/65	0,64/0,87	74,3/81,4	74,3/81,4	74,3/81,4	3,7/6,4	1,8/2,3	2,2/3,0	0,054	105
3,5/14	VGMD 160 L 8/4	720/1460	10,5/28	46/92	0,60/0,83	78,3/85,4	78,3/85,4	78,3/85,4	3,7/6,8	1,8/2,0	2,0/2,5	0,072	140
4/16	VGMD 180 M 8/4	720/1465	11,4/32	53/104	0,63/0,82	79,3/86,4	79,3/86,4	79,3/86,4	3,8/6,0	1,8/2,3	1,8/2,4	0,11	150
5/20	VGMD 180 L 8/4	720/1465	14/40	66/130	0,62/0,81	81,3/87,4	81,3/87,4	81,3/87,4	3,9/6,7	1,9/2,5	1,9/2,7	0,13	170
7/28	VGMD 200 L 8/4	725/1465	16/51	92/183	0,73/0,88	84,2/88,4	84,2/88,4	84,2/88,4	4,5/6,6	1,9/2,1	1,9/2,4	0,19	235
8/32	VGMD 225 S 8/4	730/1470	20/60	105/208	0,67/0,86	84,3/86,5	84,3/86,5	84,3/86,5	4,3/6,6	2,0/2,3	2,1/2,7	0,29	275
10/40	VGMD 225 M 8/4	725/1470	26/71	132/260	0,65/0,92	84,4/89,5	84,4/89,5	84,4/89,5	4,0/6,3	1,8/2,3	1,8/2,4	0,35	320
12,5/48	VGMD 250 M 8/4	735/1475	30/87	162/311	0,70/0,88	87,3/88,6	87,3/88,6	87,3/88,6	4,3/7,1	2,0/2,5	1,9/2,9	0,54	395
16,5/63	VGMD 280 S 8/4	730/1475	38/115	216/408	0,70/0,88	88,4/90,6	88,4/90,6	88,4/90,6	3,8/6,3	1,6/2,2	1,8/2,4	0,90	550
21/83	VGMD 280 M 8/4	735/1475	50/149	273/537	0,67/0,87	90,4/91,6	90,4/91,6	90,4/91,6	3,9/6,9	1,6/2,3	1,8/2,5	1,1	615
25/100	VGMD 315 S 8/4	740/1480	53/174	323/643	0,74								

DOUBLE SPEED SMOKE EXTRACTION MOTORS

F300

OPERATIONAL CHARACTERISTICS

3 Phase, 400 V, 50 Hz | Type of Operation: S2 + S1 Protection Degree: IP 55 | Insulation Class H (180°C) Heat Increase Limit: B (80K)

Load torque proportional to the square of the speed (Pump and Ventilator)
Single winding - Dahlander Connection Y/YY

Nominal Power kW	Type	At Nominal Power					At Start-up		Tilting Moment Ratio	Moment of Inertia	Approx. Weight
		Speed RPM	Current A	Torque Nm	Power Coefficient Cos φ	Efficiency η 4/4	Current Ratio Direct	Torque Ratio Direct			

6/4 poles (1000/1500 RPM)

0,15/0,45	VGMD 80 6/4a	930/1370	0,54/1,3	1,54/3,14	0,77/0,81	50,5/60,4	3,2/3,2	1,7/1,4	2,1/1,5	0,0017	13,3
0,2/0,6	VGMD 80 6/4b	960/1400	0,74/1,52	2,03/4,09	0,67/0,8	56,4/69,2	3,7/3,8	2,1/1,6	2,7/2	0,0022	14,7
0,3/0,9	VGMD 90 S 6/4	940/1410	1,1/2,3	3,05/6,1	0,7/0,78	54,5/70,2	2,9/4,3	1,3/1,9	1,9/2,1	0,0019	17,8
0,37/1,1	VGMD 90 L 6/4	935/1390	1,2/2,8	3,8/7,6	0,71/0,78	61,3/71,2	3,2/4	1,6/1,6	2/2,1	0,0024	20,8
0,6/1,6	VGMD 100 L 6/4a	950/1420	1,85/4,1	6/10,8	0,73/0,79	62,4/69,3	3,6/5,2	1,6/2,1	2,2/2,3	0,0040	27,8
0,75/2,2	VGMD 100 L 6/4b	950/1430	2,5/5,3	7,5/14,7	0,68/0,8	62,4/73,3	3,6/4,7	1,7/1,7	2,2/2,3	0,0052	31,3
1,1/3,3	VGMD 112 M 6/4	955/1440	3,1/7,3	11/21,9	0,7/0,81	71,2/79,2	5/5,8	1,9/2,1	2,9/2,7	0,0092	41
1,5/4,5	VGMD 132 S 6/4	940/1440	4,2/9,5	15,2/29,8	0,75/0,84	67,4/79,3	4,1/5,5	1,7/1,8	2,1/2	0,019	51
2/6,2	VGMD 132 M 6/4	940/1440	5,2/13,3	20,3/41,1	0,77/0,86	70,3/76,4	4/5,2	1,7/2	1,9/2,2	0,026	60
3/9	VGMD 160 M 6/4	945/1455	7/18	30,3/59,1	0,78/0,84	77,3/84,3	4,6/6	1,8/2	1,9/2,3	0,054	105
4/13	VGMD 160 L 6/4	970/1455	9,5/26	39,4/85,3	0,75/0,84	79,3/84,4	4/5,5	1,9/2,1	1,9/2,2	0,072	140
5/15	VGMD 180 M 6/4	970/1460	11,7/29	49/98	0,74/0,85	81,3/86,3	4,4/5,9	1,8/2,2	1,9/2,2	0,11	150
6/18,5	VGMD 180 L 6/4	975/1455	14/36	59/121	0,75/0,85	80,3/85,4	5,4/5,5	2,4/2,1	2,5/2,3	0,13	170
7,5/25	VGMD 200 L 6/4	980/1465	16,6/48	73/163	0,79/0,86	81,3/85,5	6/6,6	2,2/2,2	2,9/2,8	0,19	235
13/33	VGMD 225 S 6/4	980/1470	25/67	107/214	0,73/0,8	85,3/87,5	5/6,4	1,8/2,1	2,2/2,8	0,29	275
14/40	VGMD 225 M 6/4	980/1470	30/77	136/260	0,78/0,83	84,4/88,5	4,7/6,1	1,8/2	2,3/3	0,35	320
17/50	VGMD 250 M 6/4	980/1474	36/92	166/324	0,8/0,85	83,4/90,5	5,2/7,2	2/2,5	2,4/3,1	0,54	395
22/65	VGMD 280 S 6/4	985/1480	46/116	213/419	0,78/0,91	87,4/87,6	6,6/5,4	2,3/1,7	2,3/1,8	0,90	550
26/75	VGMD 280 M 6/4	990/1480	56/137	251/484	0,75/0,89	87,4/87,6	6,8/5,5	2,5/1,6	2,5/1,7	1,1	615
32/95	VGMD 315 S 6/4	990/1480	63/164	309/613	0,81/0,9	89,4/91,6	6,7/6	2,2/1,7	2,5/2,2	1,6	702
37/115	VGMD 315 M 6/4a	990/1485	74/200	357/740	0,79/0,88	89,5/92,6	8,7/4	2,5/1,8	2,9/2,6	2,1	784
45/132	VGMD 315 M 6/4b	990/1485	91/223	434/849	0,78/0,91	90,5/92,7	8/6,5	2,5/1,8	2,9/2,5	2,5	861

DIMENSIONS FULLY CLOSED COOLED WITH AIR PASSING OVER (TEAO) MOTORS

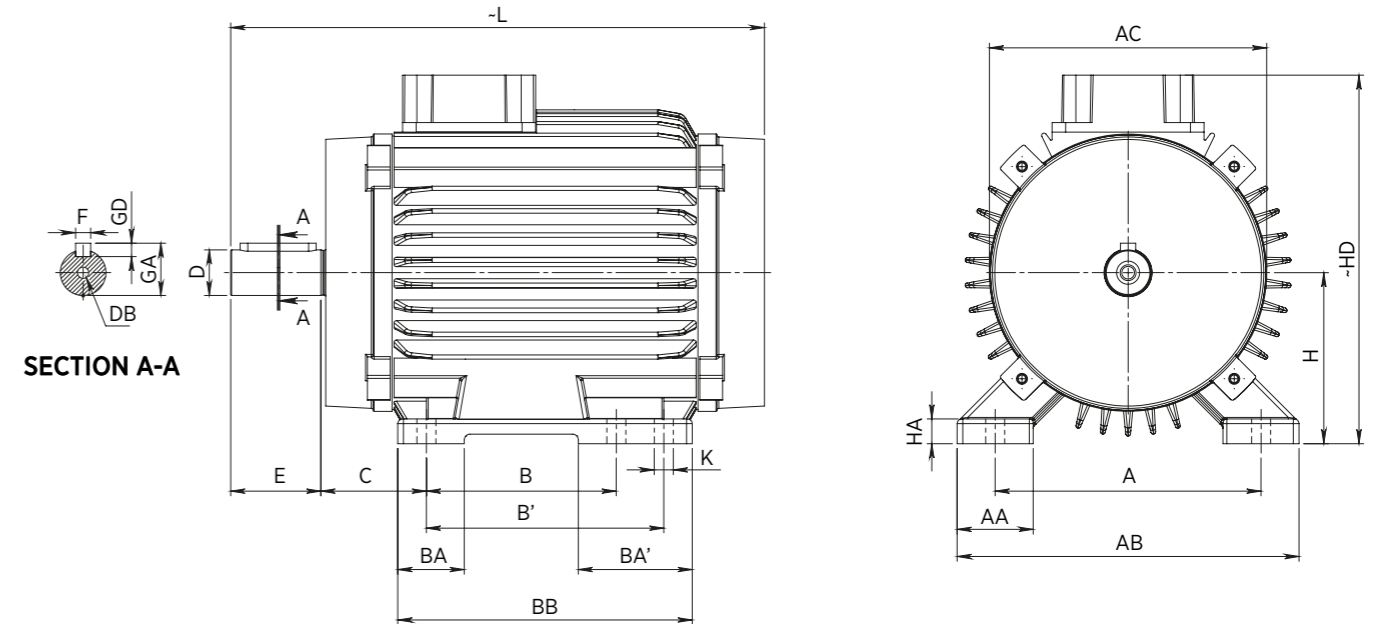

FOOT-MOUNTED (B3) - CAST IRON FRAME

Frame Size	No of Poles	H	HD	HA	A	AA	AB	ACØ	KØ	B	B'	BA	BA'	BB	L	C	E	DB	DØ	GA	FxGD	
80	2-4-6-8	80	177	12	125	40	160	152	10	100	-	30	-	125	237	50	40	M6	19	21,5	6x6	
90	S L	2-4-6-8	90	196	13	140	40	180	10	100	-	35	-	130	259	56	50	M8	24	27	8x7	
										125				155	290							310
100	L	2-4-6-8	100	214	14	160	40	200	12	140	-	37,5	-	175	322	63	60	M10	28	31	8x7	
															349							
112	M	2-4-6-8	112	236	14	190	47,5	235	12	140	-	42,5	-	175	343,5	70	60	M10	28	31	8x7	
															362,5							
132	S M	2-4-6-8	132	291	15	216	52	260	12	140	-	46	84	218	430	89	80	M12	38	41	10x8	
										-					178							
160	M L	2-4-6-8	160	377	21,5	254	60	312	15	210	-	62	-	260	527,5	108	110	M16	48	45	12x8	
										254				304	571,5							
180	M L	2-4-6-8	180	416	24	279	68	354	15	241	279	57	85	319	583,5	121	110	M16	46	51,5	14x9	
										279	-	62	-	329	621,5							
200	L	2-4-6-8	200	455	26	318	80	398	19	305	-	68	-	355	669,5	133	110	M20	55	59	16x10	
															669,5							
250	M	2-4-6-8	250	505	35	406	80	484	24	349	-	75	-	410	814,5	168	140	M20	60	64	18x11	
															65				69			
280	S	2-4-6-8	280	563	40	457	120	550	24	368	-	85	128	474	872,5	190	140	M20	65	69	18x11	
																			75	79,5	20x12	
	M	2-4-6-8	280	563	40	457	120	550	544	24	-	419	-	-	-	-	-	-	-	65	69	20x12
																				75	79,5	18x11
315	S	2-4-6-8	315	656	50	508	125	620	614	28	406	-	115	166	550	1020	216	140	M20	65	69	18x11
																1050				170	22x14	
	M	2-4-6-8	315	656	50	508	125	620	614	28	-	457	-	-	-	-	-	-	-	65	69	22x14
																				1020	140	22x14

All motors are made of cast iron.

Efficiency values are calculated by the indirect measurement method in accordance with the IEC 60034-2-1: 2014 standard. Additional losses are assessed based on test results performed at variable load values.

OPERATIONAL CHARACTERISTICS
3 Phase, 400 V, 50 Hz | Type of Operation: S1 (Continuous Operation)
Protection Degree: IP 55 | Insulation Class H (180°C) | Heat Increase Limit: B (80K)

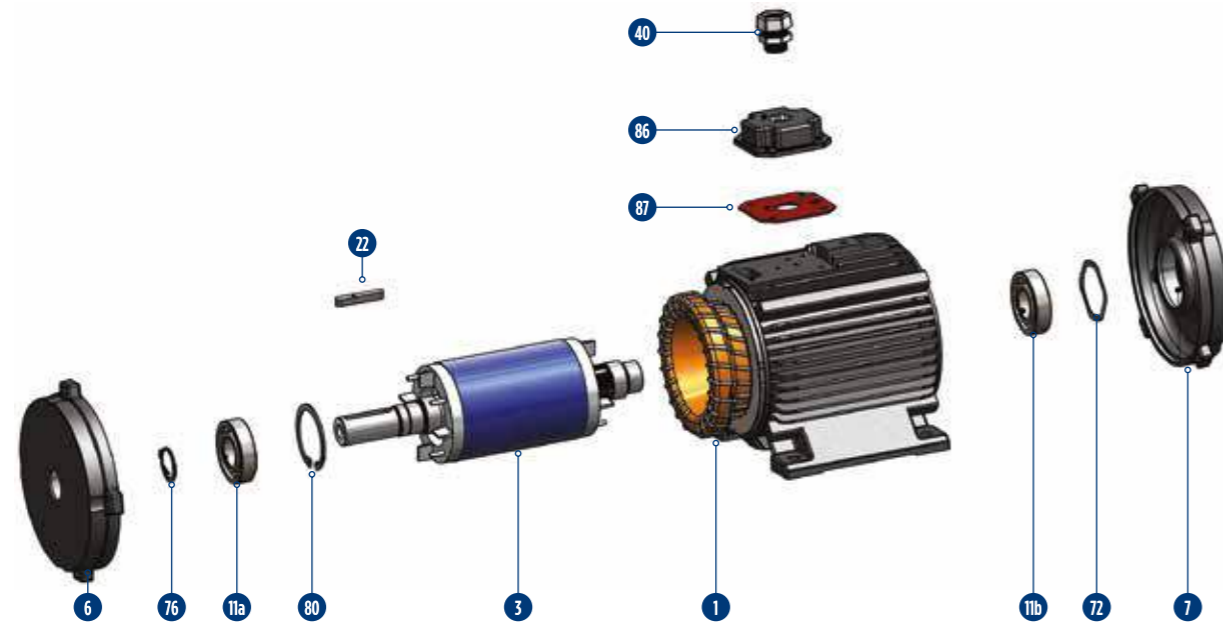

- 1** Stator with Complete Windings: Varnished and installed to the body
- 3** Complete Rotor: With balanced, shaft, machined (excluding keys)
- 6** Front cover
- 7** Rear cover
- 11a** Front Bearing
- 11b** Rear bearing
- 22** Shaft End Wedge
- 40** Cable entry gland
- 72** Disc spring
- 76** Outer snap
- 80** Inner snap
- 86** Smoke motor terminal cover
- 87** Smoke motor terminal cover seal

Nominal Power kW	Type	At Nominal Power							At Start-up				Tilting Moment Ratio	Moment of Inertia	Approx. Weight
		Speed	Current	Torque	Power Coefficient Cos φ	Efficiency η			Current Ratio		Torque Ratio				
		RPM	A	Nm		4/4	3/4	1/2	Direct	Y/Δ	Direct	Y/Δ			

2 poles (3000 RPM)

0,75	GM2EPAD 80 M 2a	2860	1,7	2,5	0,82	77,4	77,4	74,6	6,2	-	2,5	-	3	0,00053	13,9
1,1	GM2EPAD 80 M 2b	2880	2,3	3,6	0,87	79,6	79,6	77,9	6,3	-	2,7	-	3	0,00066	14,8
1,5	GM2EPAD 90 S 2a	2880	3,3	5	0,81	81,3	81,3	79,8	6,3	-	2,3	-	3	0,0011	18
2,2	GM2EPAD 90 L 2b	2870	4,5	7,3	0,85	83,2	83,2	81,9	6,6	-	2,6	-	3,1	0,0014	22,9
3	GM2EPAD 100 L 2a	2880	5,8	9,9	0,88	84,6	84,6	84,1	6	-	2,5	-	3	0,0025	30,4

4 poles (1500 RPM)

0,55	GMPAD 80 M 4a	1365	1,60	3,8	0,72	69,1	69	65,2	3,5	-	1,9	-	2	0,00083	14,8
0,75	GM2EPAD 80 M 4b	1410	2	5,1	0,68	79,6	79,6	77,6	5	-	2,6	-	2,8	0,0014	16,5
1,1	GM2EPAD 90 S 4a	1420	2,6	7,4	0,75	81,4	81,4	80,5	5,5	-	3	-	3,3	0,0022	19,1
1,5	GM2EPAD 90 L 4b	1430	3,5	10	0,75	82,8	82,8	81,5	5,9	-	3,3	-	3,5	0,003	22,4
2,2	GM2EPAD 100 L 4a	1420	4,9	14,8	0,77	84,3	84,3	82,5	5,6	-	2,4	-	2,7	0,0044	32,4
3	GM2EPAD 100 L 4b	1435	6,7	20	0,76	85,5	85,7	84	6,4	-	2,9	-	3,4	0,0057	36,4

PAD MOUNTED SMOKE EXTRACTION MOTORS

F300

OPERATIONAL CHARACTERISTICS

3 Phase, 400 V, 50 Hz | Type of Operation: S1 (Continuous Operation)
 Protection De-gree: IP 55 | Insulation Class H (180°C) | Heat Increase Limit: B (80K)

Nominal Power kW	Type	At Nominal Power					At Start-up		Tilting Moment Ratio	Moment of Inertia	Approx. Weight
		Speed RPM	Current A	Torque Nm	Power Coefficient Cos φ	Efficiency η 4/4	Current Ratio Direct	Torque Ratio Direct			

4/2 poles (1500/3000 RPM)

0,17/0,75	V.GMPAD 80 4/2a	1400 / 2790	0,5 / 1,7	1,2 / 2,6	0,77 / 0,91	62,2 / 68,3	3,5 / 4,1	1,6 / 1,7	1,9 / 1,9	0,00053	13,65
0,25/1	V.GMPAD 80 4/2b	1410 / 2810	0,7 / 2,2	1,7 / 3,4	0,75 / 0,98	67,1 / 65,4	3,3 / 3,6	1,4 / 1,6	1,7 / 1,9	0,00066	14,6
0,33/1,3	V.GMPAD 90 S 4/2	1425 / 2860	0,9 / 2,8	2,2 / 4,3	0,74 / 0,87	70,1 / 75,2	3,7 / 4,4	1,6 / 1,8	2 / 1,9	0,00110	17,7
0,5/2	V.GMPAD 90 L 4/2	1415 / 2835	1,2 / 4,2	3,4 / 6,7	0,78 / 0,88	75 / 76,2	4,5 / 6	2 / 1,8	2,4 / 2,5	0,00140	20,6
0,66/2,7	V.GMPAD 100 L 4/2	1430 / 2845	1,5 / 5,2	4,4 / 9,1	0,81 / 0,95	76 / 77,2	4,9 / 4,7	1,7 / 1,9	2,3 / 2,1	0,00240	23,1

8/4 poles (750/1500 RPM)

0,12/0,5	V.GMPAD 80 8/4a	680 / 1430	0,7 / 1,5	1,7 / 3,3	0,51 / 0,75	50,5 / 62,3	2,1 / 3,2	1,4 / 1,7	1,7 / 2,1	0,00083	13,4
0,18/0,75	V.GMPAD 80 8/4b	680 / 1405	0,9 / 2	2,5 / 5,1	0,54 / 0,81	51,5 / 65,3	2,1 / 3,5	1,6 / 1,7	1,8 / 2,1	0,00110	14,1
0,25/0,1	V.GMPAD 90 S 8/4	700 / 1410	1,2 / 2,8	3,4 / 6,8	0,51 / 0,69	57,4 / 73,2	2,7 / 4,6	1,6 / 2,1	2,1 / 2,4	0,00190	18,5
0,33/1,4	V.GMPAD 90 L 8/4	690 / 1390	1,3 / 3,3	4,6 / 9,6	0,6 / 0,79	59,4 / 76,2	2,6 / 4,3	1,7 / 1,8	1,9 / 2,1	0,00240	20,4
0,5/2	V.GMPAD 100 L 8/4a	700 / 1415	1,8 / 4,8	7 / 13	0,61 / 0,82	64,3 / 71,3	2,9 / 4,8	1,5 / 1,8	2,1 / 2,3	0,00380	22,8
0,6/2,5	V.GMPAD 100 L 8/4b	690 / 1410	2 / 5,5	8 / 17	0,66 / 0,86	64,3 / 74,3	3,2 / 5,2	1,5 / 1,9	2 / 2,3	0,00500	23,3

8/4 poles (750/1500 RPM)

0,15/0,45	V.GMPAD 80 6/4a	930 / 1370	0,5 / 1,3	1,5 / 3,1	0,77 / 0,81	50,5 / 60,4	3,2 / 3,2	1,7 / 1,4	2,1 / 1,5	0,00170	13,3
0,2/0,6	V.GMPAD 80 6/4b	960 / 1400	0,7 / 1,5	2 / 4,1	0,67 / 0,8	56,4 / 69,2	3,7 / 3,8	2,1 / 1,6	2,7 / 2	0,00220	14,3
0,3/0,9	V.GMPAD 90 S 6/4	940 / 1410	1,1 / 2,3	3,1 / 6,1	0,7 / 0,78	54,5 / 70,2	2,9 / 4,3	1,3 / 1,9	1,9 / 2,1	0,00190	17,7
0,37/1,1	V.GMPAD 90 L 6/4	935 / 1390	1,2 / 2,8	3,8 / 7,6	0,71 / 0,78	61,3 / 71,2	3,2 / 4	1,6 / 1,6	2 / 2,1	0,00240	21,8
0,6/1,6	V.GMPAD 100 L 6/4a	950 / 1420	1,9 / 4,1	6 / 10,8	0,73 / 0,79	62,4 / 69,3	3,6 / 5,2	1,6 / 2,1	2,2 / 2,3	0,00400	28,8
0,75/2,2	V.GMPAD 100 L 6/4b	950 / 1430	2,5 / 5,3	7,5 / 14,7	0,68 / 0,8	62,4 / 73,3	3,6 / 4,7	1,7 / 1,7	2,2 / 2,3	0,00520	30,0

PAD MOUNTED SMOKE EXTRACTION MOTORS

OPERATIONAL CHARACTERISTICS

3 Phase, 400 V, 50 Hz | Type of operation: S1 (Continuous Operation)
 Protection De-gree: IP 55 | Insulation Class H (180°C) | Heat Increase Limit: B (80K)

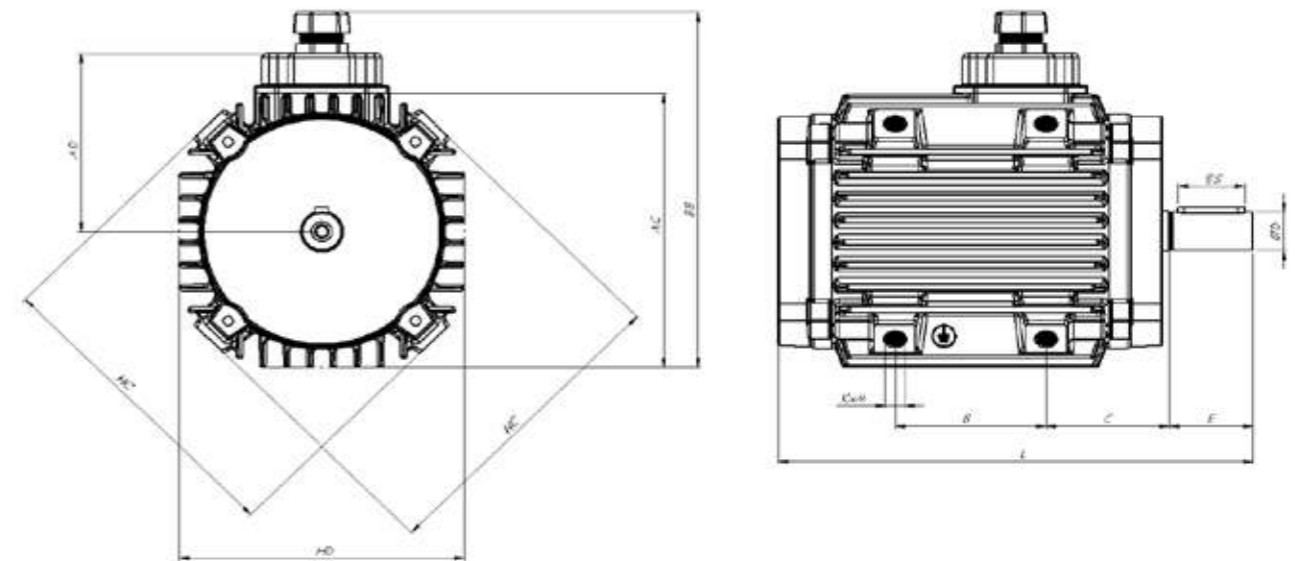

Frame	AC	AD	B	BB	C	E	ØD	ES	HC	HD	L	KxM
80	156	103	80	207	60	50	19	40	170	156	253	M12x1,5x18
90-S	176	113	65	227	73,5	50	24	40	190	176	256,5	M12x1,5x18
90-L	176	113	90	227	73,5	50	24	40	190	170	283	M12x1,5x18
100-L	197,5	125	100	251	83	60	28	50	210	200	322	M12x1,5x18

In variable torque applications, depending on the start-up current characteristic, dual speed motors must be started first at low speed. It can be switched to high speed after reaching the rated speed.

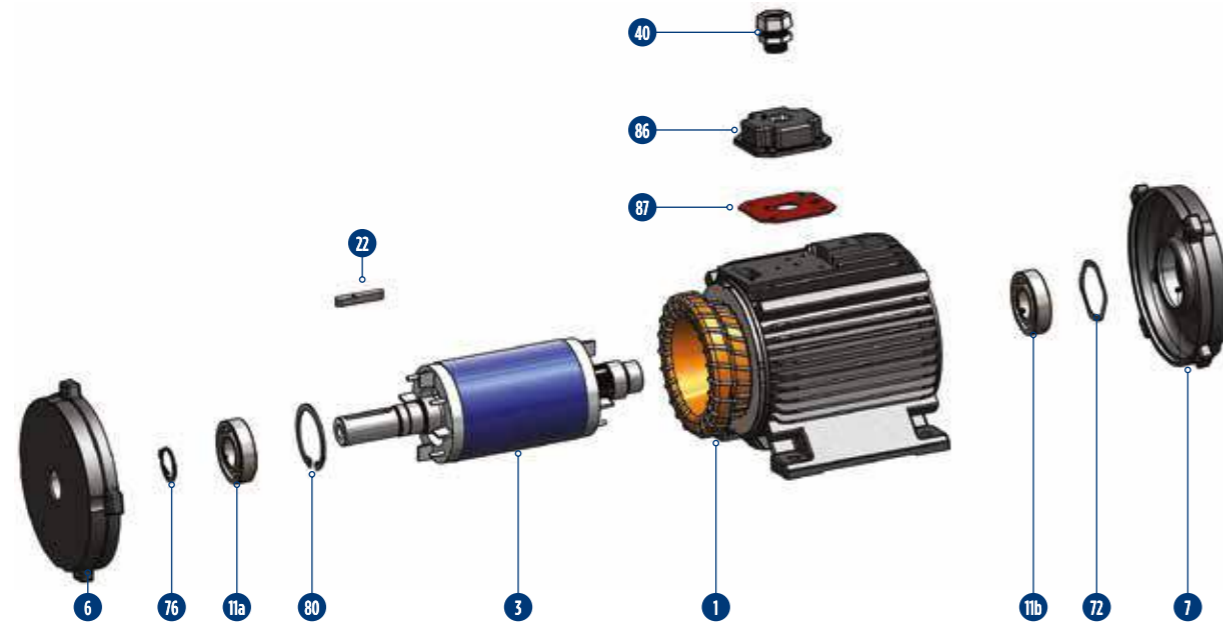

- 1 Stator with Complete Windings: Varnished and installed to the body
- 3 Complete Rotor: With balanced, shaft, machined (excluding keys)
- 6 Front cover
- 7 Rear cover
- 11a Front bearing
- 11b Rear bearing
- 22 Shaft End Wedge
- 40 Cable entry gland
- 72 Disc spring
- 76 Outer snap
- 80 Inner snap
- 86 Smoke motor terminal cover
- 87 Smoke motor terminal cover seal



SPECIAL
SERIES



EX-PROOF
MOTORS



GAMAK FLAME PROOF GM SERIES EX-PROOF MOTORS

OPERATIONAL CHARACTERISTICS
3 Phase, 400 V, 50 Hz | Type of Operation: S1 (Continuous Operation)
Protection Degree: IP 65 | Insulation Class F (155°C)
Heat Increase Limit: B (80K) | Cooling: TEFC

• It is a 3-phase, squirrel-cage, asynchronous electric motor group categorized as 71-80-90 S -90 L - 100 L - 112 M -132 S -132 M -160 M -160 L -180 M -180 L -200 L -225 MS - 250 M according to IEC standards, and designed to meet the criteria specific to the relevant types. It is electrically designed for 2-4-6 or 8 poles that can be operated with direct supply.

• In motors designed in flameproof Class D structure, casing components are cast iron.

• Designed to work in flammable and explosive dust and gaseous environments, the product has a body, front cover, rear cover, terminal box, terminal box cover and gland-blind plug entries, as well as the stator and shaft rotor group that make up the motor. The terminal group featuring electrical connections and cables to run the motor is located in the terminal box.

• The order of installation has been prepared in B3 and B35 structure.

• Ex-Proof motors in the series can be produced in F or H insulation classes upon request. While Class F insulation together with the copper and insulation varnish that make up the stator withstand temperatures up to 155 degrees according to the relevant standards, this resistance limit is defined as 180 degrees for Class H insulation. Insulation resistance is not related to maximum surface temperature.

• All Gamak ex-proof motors are produced with thermistor protection elements with an opening limit of 130 degrees. Thus, if the temperature of the winding heads in the motor reaches the relevant degree, the thermistor will prevent the electric current from reaching the motor, protecting the motor against overheating. It is the user's responsibility to make the thermistor connections.

• In order to limit the risks that may arise from static electricity in the products, the paint thickness on the protection casing is limited to 200 microns, and the rotating plastic propeller raw material is selected from a special raw material with a surface resistance of less than E9 ohms.

• The operating temperature range of the motors in the series is limited to -20 / +40 degrees.

• The end user must not paint the motor.

• Making the ground connections is the responsibility of the end user.

• Motors are at nominal operating values of 220/380 380/400 400/690 50 Hz.

• Motors are designed in conformance with the S1 operating style. For different operating values (S2-S3..etc.), maximum surface temperature tests must be performed and verified.

• Motors are designed as II 2G Exd IIC T4 Gb for gaseous environment and II 2D Extb T135 Db for dusty environment.

• All technical information about the product, the responsibilities of the end user, and definitions regarding the quality management system can be found in the user manual provided with the motor. The end user will be responsible for the product after they start operating it.

• C (if it is a compact motor) GM (1-2-3) Exd (71-80-160...) (S-M-L-MS) (2-4-6-8) (a-b-c) is used as the coding structure on the motor label.

- GM : Gamak Ex-proof motors
- 1-2-3 : Energy efficiency class definition (IE1-IE2-IE3)
- Exd : Motor with Class d protection structure
- 71-80-90 : Motor type defined according to IEC regulations
- S-M-L-SM : Body length
- 2-4-6-8 : Number of Poles
- a-b-c : Package size

CAST IRON FRAME

Nominal Power	Type	At Nominal Power							At Start-up				Tilting Moment Ratio	Moment of Inertia	Approx. Weight
		Speed	Current	Torque	Power Coefficient Cos φ	Efficiency η			Current Ratio		Torque Ratio				
kW		RPM	A	Nm		4/4	3/4	1/2	Direct	Y/Δ	Direct	Y/Δ			

2 poles (3000 RPM);

0,37	GMIExd 71 2a	2800	1,05	1,26	0,74	68,9	68,7	66,7	5,0	-	2,4	-	2,6	0,00026	16,4
0,55	GMIExd 71 2b	2780	1,30	1,9	0,85	72,0	71,8	70,3	4,5	-	2,4	-	2,6	0,00034	17,6
0,75	C.GMIExd 71 2	2760	1,75	2,60	0,86	72,1	72,5	72,3	4,5	-	2,2	-	2,4	0,00039	18,4
0,75	GMIExd 80 2a	2800	1,9	2,56	0,76	75,3	75,3	74,5	4,2	-	2,4	-	2,8	0,00053	24,3
1,1	GMIExd 80 2b	2800	2,55	3,75	0,80	78,1	78	77,4	4,0	-	2,1	-	2,5	0,00066	25,8
1,5	C.GMIExd 80 2	2825	3,5	5,07	0,80	77,2	77,2	77	5,4	-	2,4	-	2,7	0,00083	27,8
1,5	GMIExd 90 S 2	2835	3,5	5,05	0,80	77,2	77,2	76,2	4,8	-	2,2	-	2,5	0,0011	29,9
2,2	GMIExd 90 L 2	2840	4,9	7,4	0,81	79,7	79,7	78	5,5	-	2,5	-	3,0	0,0014	34,1
3	C.GMIExd 90 L 2	2840	6,5	10,1	0,82	81,5	81,5	81,0	6,1	-	2,8	-	2,9	0,0016	36,6
3	GMIExd 100 L 2	2830	6,45	10,1	0,83	81,5	81,5	80,4	6,1	-	2,7	-	3,3	0,0025	46,4
4	GMIExd 112 M 2	2850	8,2	13,4	0,85	83,1	83,1	83,2	6,0	1,9	2,6	0,8	3,0	0,0039	51,6
5,5	C.GMIExd 112 M 2	2870	11	18,3	0,85	84,7	84,7	83,8	7,0	2,3	2,8	0,9	3,3	0,0048	56,7
5,5	GMIExd 132 S 2a	2870	11,3	18,3	0,83	84,7	84,7	84	5,9	1,9	2,4	0,8	2,9	0,013	83,9
7,5	GMIExd 132 S 2b	2890	15,4	24,8	0,82	86	86	85,9	5,8	1,9	2,6	0,8	3,0	0,014	93,9
11	GMIExd 160 M 2a	2935	22,4	35,8	0,84	87,6	87,6	87,5	7,2	2,3	2,9	0,9	2,9	0,027	143,1
15	GMIExd 160 M 2b	2940	28,5	48,7	0,86	88,7	88,7	88,5	7,6	2,5	2,8	0,9	2,8	0,035	153,7
18,5	GMIExd 160 L 2	2940	35	60,1	0,85	89,3	89,3	89	7,6	2,5	2,8	0,9	3,1	0,043	176,1
22,0	GMIExd 180 M 2	2945	41,5	71,3	0,85	89,9	89,9	89	7,5	2,5	2,5	0,8	2,8	0,066	259,5
30	GMIExd 200 L 2a	2940	56	97,4	0,85	90,7	90,7	90,2	7,2	2,4	2,6	0,8	2,8	0,13	360,7
37	GMIExd 200 L 2b	2955	68	119,5	0,86	91,2	91,2	90,5	7,7	2,5	2,6	0,8	2,8	0,15	386,5
45	GMIExd 225 M 2	2960	82	145	0,86	91,7	91,7	91	6,9	2,3	2,3	0,7	2,7	0,23	445,3
55	GMIExd 250 M 2	2970	100	177	0,86	92,1	92,3	92,0	6,8	2,2	2,4	0,8	2,5	0,32	517
75	C.GMIExd 250 M 2	2970	134	241	0,91	92,7	92,7	92,0	6,8	2,2	2,2	0,7	2,4	0,4	570,9

4 poles (1500 RPM);

0,25	GMIExd 71 4a	1380	0,80	1,7	0,72	61,9	61,8	58,2	2,9	-	1,8	-	2,2	0,0004	16,4
0,37	GMIExd 71 4b	1390	1,15	2,5	0,68	68,1	68,1	67,1	3,7	-	2,2	-	2,5	0,00054	17,6
0,55	C.GMIExd 71 4	1385	1,60	3,8	0,75	68,6	68,6	67,6	3,4	-	1,9	-	2,1	0,00062	18,4
0,55	GMIExd 80 4a	1365	1,60	3,8	0,72	69,1	69,0	65,2	3,5	-	1,9	-	2,0	0,00083	24,3
0,75	GMIExd 80 4b	1370	2,1	5,23	0,75	72,2	72,2	70,2	3,5	-	1,9	-	2,0	0,00110	25,8
1,1	C.GMIExd 80 4	1365	3,1	7,7	0,69	74,0	74,0	73,0	4,0	-	2,1	-	2,1	0,00134	27,8
1,1	GMIExd 90 S 4	1380	2,7	7,61	0,78	75,0	75,0	73,9	4,3	-	2,2	-	2,4	0,00190	29,3
1,5	GMIExd 90 L 4	1385	3,6	10,3	0,78	77,2	77,2	76,0	4,6	-	2,4	-	2,6	0,00240	32,8
2,2	C.GMIExd 90 L 4	1380	5,4	15,2	0,74	79,7	79,7	78,7	4,3	-	2,6	-	2,7	0,0029	36,6
2,2	GMIExd 100 L 4a	1405	5,3	15,0	0,76	79,7	79,7	79,0	4,9	-	2,3	-	2,7	0,0044	50,2
3	GMIExd 100 LH 4b	1405	6,9	20,4	0,78	81,5	81,4	80,8	5,9	-	2,8	-	3,3	0,005	58,6
4	GMIExd 112 M 4	1425	8,6	26,8	0,81	83,1	83,1	83,0	5,5	1,8	2,5	0,8	2,9	0,0092	58,7
5,5	GMIExd 132 S 4	1430	11,8	36,7	0,79	84,7	84,7	84	5,8	1,9	2,4	0,8	2,5	0,021	92,2
7,5	GMIExd 132 M 4	1430	15,8	50,1	0,83	86	86	85,9	5,8	1,9	2,4	0,8	2,5	0,026	109,9
11	GMIExd 160 M 4	1455	22,6	72,2	0,80	87,6	87,5	87	6,5	2,1	2,6	0,8	2,7	0,061	157,3
15	GMIExd 160 L 4	1460	30,5	98,1	0,80	88,7	88,7	88,3	6,7	2,2	2,6	0,8	2,7	0,082	181,4
18,5	GMIExd 180 M 4	1460	38	121,0	0,79	89,3	89,3	88,5	6,2	2,0	2,7	0,9	2,8	0,13	268,0
22	GMIExd 180 L 4	1455	22	144,4	0,80	89,9	89,9	89	6,5	2,2	2,6	0,8	2,7	0,15	294,2
30	GMIExd 200 L 4	1460	57	196,2	0,84	90,7	90,7	90	6,5	2,1	2,5	0,8	2,7	0,227	368
37	GMIExd 225 S 4	1465	70	241,2	0,84	91,2	91,4	91	6,3	2,1	2,4	0,8	2,6	0,3	411,8
45	GMIExd 225 M 4	1465	84	293,3	0,84	91,7	91,7	90,8	6,0	2,0	2,5	0,8	2,6	0,36	441,3
55	GMIExd 250 M 4	1470	102	357,0	0,85	92,1	92,3	92,0	6,8	2,2	2,8	0,9	2,4	0,54	512,7
75	C.GMIExd 250 M 4	1470	140	487,0	0,83	92,7	92,8	92,0	7,0	2,3	2,9	0,9	2,7	0,73	579,8

Efficiency values are calculated by the indirect measurement method in accordance with the IEC 60034-2-1: 2014 standard. Additional losses are assessed based on test results performed at variable load values.

EX-PROOF SERIES - OPERATIONAL CHARACTERISTICS STANDARD EFFICIENCY MOTORS

IE1

OPERATIONAL CHARACTERISTICS

3 Phase, 400 V, 50 Hz | Type of Operation: S1 (Continuous Operation)
 Protection Degree: IP 65 | Insulation Class F (155°C)
 Heat Increase Limit: B (80K) | Cooling: TEFC

CAST IRON FRAME

Nominal Power	Type	At Nominal Power							At Start-up				Tilting Moment Ratio	Moment of Inertia	Approx. Weight
		Speed	Current	Torque	Power Coefficient Cos φ	Efficiency η			Current Ratio		Torque Ratio				
		RPM	A	Nm		4/4	3/4	1/2	Direct	Y/Δ	Direct	Y/Δ			

6 poles (1000 RPM)

0,18	GM1Exd 71 6a	915	0,60	1,9	0,68	63,0	62,9	58,7	3,2	-	1,7	-	2,1	0,00064	16,4
0,25	GM1Exd 71 6b	915	0,87	2,6	0,68	63,8	63,7	59,6	3,2	-	1,7	-	2,1	0,00086	17,6
0,37	GM1Exd 80 6a	910	1,10	3,9	0,67	72,9	72,8	70,1	3,6	-	2,1	-	2,4	0,0017	25,3
0,55	GM1Exd 80 6b	890	1,50	5,9	0,75	70,4	70,3	68,2	3,5	-	1,9	-	2,0	0,0022	27,3
0,75	GM1Exd 90 S 6	900	2,2	7,96	0,70	70	70	68,8	3,4	-	3,4	-	1,6	1,7	29,3
1,1	GM1Exd 90 L 6	910	3,0	11,5	0,73	72,9	72,9	71,5	3,5	-	3,5	-	1,8	1,9	32,8
1,5	GM1Exd 100 L 6	925	3,7	15,5	0,78	75,2	75,2	75	4,5	-	2,0	-	2,2	0,0077	46,4
2,2	GM1Exd 112 M 6	940	5,3	22,4	0,77	77,7	77,8	77,5	4,6	-	4,6	-	2,1	2,4	56,7
3	GM1Exd 132 S 6	945	7,4	30,3	0,74	79,7	79,9	79,9	5,1	1,6	2,1	0,7	2,4	0,019	80,6
4	GM1Exd 132 M 6a	940	9,4	40,6	0,75	81,4	81,4	80,9	4,5	1,5	2,2	0,7	2,4	0,024	91,6
5,5	GM1Exd 132 M 6b	945	13	55,6	0,73	83,1	83,1	83	5,0	1,6	2,3	0,7	2,3	0,032	103,2
7,5	GM1Exd 160 M 6	960	16	74,6	0,80	84,7	84,7	84	6,7	2,2	2,5	0,8	2,9	0,076	157,3
11,0	GM1Exd 160 L 6	955	23	110,0	0,80	86,4	86,4	86	6,7	2,2	2,5	0,8	3,0	0,109	181,4
15	GM1Exd 180 L 6	960	30,5	149,2	0,81	87,7	87,7	87	5,8	1,9	2,2	0,7	2,7	0,2	277,2
18,5	GM1Exd 200 L 6a	970	38	182,1	0,79	88,6	88,6	88,4	6,2	2,0	2,1	0,7	2,9	0,234	327,5
22,0	GM1Exd 200 L 6b	975	45	215,5	0,79	89,2	89,2	88,4	7,3	2,4	2,3	0,7	3,4	0,283	353,3
30	GM1Exd 225 M 6	975	61	293,8	0,79	90,2	90,2	89,5	5,9	1,9	3,1	1,0	2,3	1,2	421,6
37	GM1Exd 250 M 6	970	75	364	0,78	90,8	91	90,5	6,5	2,1	2,6	0,8	2,2	0,77	535,1
45	CGM1Exd 250 M 6	980	90	439	0,79	91,4	91,4	90,8	6,5	2,2	3,0	1,0	2,2	0,99	597,7

8 poles (750 RPM)

0,09	GM1Exd 71 8a	690	0,4	1,2	0,56	56,5	56,5	47,4	2,3	-	1,7	-	1,9	0,00064	16,4
0,12	GM1Exd 71 8b	670	0,6	1,7	0,51	56,7	56,7	47,7	2,2	-	1,9	-	2,0	0,00086	17,6
0,18	GM1Exd 80 8a	695	0,9	2,5	0,48	60,3	60,3	54,7	3,0	-	2,8	-	3,0	0,0017	25,3
0,25	GM1Exd 80 8b	680	1,10	3,5	0,50	63,0	63,0	57,6	2,9	-	2,6	-	2,8	0,0022	27,3
0,37	GM1Exd 90 S 8	690	1,3	5,1	0,60	66,7	66,7	61,5	3,2	-	1,8	-	2,0	0,0029	29,9
0,55	GM1Exd 90 L 8	670	1,80	7,8	0,63	69,6	69,6	64,6	3,0	-	1,4	-	1,7	0,0038	36
1,5	GM1Exd 112 M 8	700	4,40	20,5	0,70	70,2	71,0	71,0	3,6	-	1,9	-	2,2	0,013	58,7
30	GM1Exd 250 M 8	735	59,0	389,8	0,82	89,8	89,8	86,2	6,1	2,0	1,8	0,6	2,6	0,92	544

Efficiency values are calculated by indirect measurement method in accordance with IEC 60034-2-1: 2014 standard. Additional losses are assessed based on test results performed at variable load values.

EX-PROOF SERIES - OPERATIONAL CHARACTERISTICS STANDARD EFFICIENCY MOTORS

IE1

OPERATIONAL CHARACTERISTICS

3 Phase, 400 V, 50 Hz | Type of Operation: S1 (Continuous Operation)
 Protection Degree: IP 65 | Insulation Class F (155°C)
 Heat Increase Limit: B (80K) | Cooling: TEFC

CAST IRON FRAME

Nominal Power	Type	At Nominal Power							At Start-up				Tilting Moment Ratio	Moment of Inertia	Approx. Weight
		Speed	Current	Torque	Power Coefficient Cos φ	Efficiency η			Current Ratio		Torque Ratio				
		RPM	A	Nm		4/4	3/4	1/2	Direct	Y/Δ	Direct	Y/Δ			

2 poles (3000 RPM)

0,75	CGM2Exd 71 2	2780	1,75	2,6	0,8	77,4	77,2	74,2	4,5	-	2,2	-	2,4	0,00039	18,4
0,75	GM2Exd 80 2a	2860	1,7	2,5	0,82	77,4	77,4	74,6	6,2	-	2,5	-	3	0,00053	24,3
1,1	GM2Exd 80 2b	2880	2,3	3,6	0,87	79,6	79,6	77,9	6,3	-	2,7	-	3	0,00066	25,8
1,5	CGM2Exd 80 2	2880	3,3	5	0,81	81,3	81,3	80,1	6,3	-	2,3	-	3	0,001	27,8
1,5	GM2Exd 90 S 2	2880	3,3	5	0,81	81,3	81,3	79,8	6,3	-	2,3	-	3	0,0011	29,9
2,2	GM2Exd 90 L 2	2870	4,5	7,3	0,85	83,2	83,2	81,9	6,6	-	2,6	-	3,1	0,0014	35,4
3	GM2Exd 100 L 2	2880	5,8	9,9	0,88	84,6	84,6	84,1	6	-	2,5	-	3	0,0025	46,4
4	GM2Exd 112 M 2	2880	7,9	13,3	0,85	85,8	85,8	85,6	7,2	2,3	2,8	0,9	3,5	0,0039	53,6
5,5	CGM2Exd 112 M 2	2905	9,9	18,1	0,92	87	87	86,5	6,2	2	2	0,6	2,5	0,0045	56,7
5,5	GM2Exd 132 S 2a	2905	9,85	18,1	0,93	87	87	86,5	6,5	2,1	2,2	0,7	2,5	0,013	83,9
7,5	GM2Exd 132 S 2b	2910	13,6	24,6	0,9	88,1	88,1	87,9	7,2	2,3	2,8	0,9	3	0,014	93,9
11	GM2Exd 160 M 2a	2945	19,3	35,7	0,92	89,4	89,4	88,6	6,6	2,1	2	0,6	2,6	0,027	143,1
15	GM2Exd 160 M 2b	2945	26,1	48,6	0,92	90,3	90,3	89,7	7,2	2,3	2,1	0,7	2,8	0,035	153,7
18,5	GM2Exd 160 L 2	2950	32,3	59,9	0,91	90,9	90,8	90,1	7,7	2,5	2,5	0,8	3	0,043	176,1
22	GM2Exd 180 M 2	2950	38,3	71,2	0,91	91,3	91,3	90,8	8,2	2,6	3	1	3,5	0,066	259,5
30	GM2Exd 200 L 2a	2970	52	96,5	0,91	92	92	91,2	8,3	2,7	2,7	0,9	3	0,13	360,7
37	GM2Exd 200 L 2b	2970	65	119	0,89	92,5	92,5	91,7	8,3	2,7	2,7	0,9	3	0,15	386,5
45	GM2Exd 225 M 2	2975	75	144,5	0,93	92,9	93	91,8	8	2,6	2,4	0,8	2,9	0,23	445,3
55	GM2Exd 250 M 2	2980	94	176,3	0,91	93,2	93,7	92,2	7,6	2,5	2,6	0,9	2,7	0,41	553

Efficiency values are calculated by the indirect measurement method in accordance with IEC 60034-2-1: 2014 standard. Additional losses are assessed based on test results performed at variable load values.

EX-PROOF SERIES - OPERATIONAL CHARACTERISTICS STANDARD EFFICIENCY MOTORS

Special Series
Ex-Proof Motors
IE2

OPERATIONAL CHARACTERISTICS

3 Phase, 400 V, 50 Hz | Type of Operation: S1 (Continuous Operation)
Protection Degree: IP 65 | Insulation Class F (155°C)
Heat Increase Limit: B (80K) | Cooling: TEFC

CAST IRON FRAME

Nominal Power	Type	At Nominal Power							At Start-up				Tilting Moment Ratio	Moment of Inertia	Approx. Weight
		Speed	Current	Torque	Power Coefficient Cos φ	Efficiency η			Current Ratio		Torque Ratio				
		RPM	A	Nm		4/4	3/4	1/2	Direct	Y/Δ	Direct	Y/Δ			

4 poles (1500 RPM)

0,55	GM2Exd 80 4a	1365	1,6	3,8	0,64	77,1	77,1	75,6	3,5	-	1,9	-	2	0,00083	25,8
0,75	GM2Exd 80 4b	1410	2	5,1	0,68	79,6	79,6	77,6	4,4	-	2,2	-	2,5	0,0014	28,3
1,1	GM2Exd 90 S 4	1420	2,6	7,4	0,75	81,4	81,4	80,5	5,5	-	3	-	3,3	0,0022	31,9
1,5	GM2Exd 90 L 4	1430	3,5	10	0,75	82,8	82,8	81,5	5,9	-	3	-	3,3	0,003	36,6
2,2	GM2Exd 100 L 4a	1420	4,9	14,8	0,77	84,3	84,3	82,5	5,6	-	2,4	-	2,7	0,0044	50,2
3	GM2Exd 100 LH 4b	1435	6,7	20	0,76	85,5	85,7	84	6,4	-	2,9	-	3,4	0,0052	59,4
4	C.GM2Exd 100 LH 4b	1440	8,5	26,5	0,78	86,6	86,7	85,3	6,6	2,2	2,5	0,8	3,3	0,0068	61,4
4	GM2Exd 112 M 4	1440	8,4	26,5	0,79	86,6	86,8	85,3	6,6	2,1	2,5	0,8	3,3	0,0106	60,7
5,5	GM2Exd 132 S 4	1465	11,2	35,9	0,81	87,7	87,7	87,2	7	2,3	2,8	0,9	3,5	0,021	92,2
7,5	GM2Exd 132 M 4	1465	15,4	48,9	0,79	88,7	88,8	88,1	7,1	2,3	2,7	0,9	3,4	0,026	109,8
11	GM2Exd 160 M 4	1460	21,6	72	0,82	89,8	89,9	89,3	6,8	2,2	2,4	0,8	3	0,061	157,3
15	GM2Exd 160 L 4	1470	29,4	97,4	0,81	90,6	90,7	89,7	7,4	2,4	2,8	0,9	3,2	0,082	181,4
18,5	GM2Exd 180 M 4	1470	34,5	120,2	0,85	91,2	91,4	90,4	7,7	2,5	3,2	1	3,4	0,13	268
22	GM2Exd 180 L 4	1470	42,5	142,9	0,82	91,6	91,6	90,6	8,3	2,7	2,7	0,9	3,8	0,15	294,2
30	GM2Exd 200 L 4	1470	53,5	194,9	0,88	92,3	92,3	92,1	7,8	2,5	2,8	0,9	2,8	0,227	368
37	GM2Exd 225 S 4	1470	67	240,4	0,86	92,7	92,7	92,2	7,2	2,3	3	1	3	0,3	411,8
45	GM2Exd 225 M 4	1470	80	292,3	0,87	93,1	93,1	92,4	7,3	2,4	3	1	3	0,36	441,3
55	GM2Exd 250 M 4	1475	96,8	356,1	0,88	93,5	93,6	93,2	7,6	2,5	3,1	1	2,9	0,72	597,7

Efficiency values are calculated by the indirect measurement method in accordance with the IEC 60034-2-1: 2014 standard. Additional losses are assessed based on test results performed at variable load values.

Special Series
Ex-Proof Motors
IE2

EX-PROOF SERIES - OPERATIONAL CHARACTERISTICS STANDARD EFFICIENCY MOTORS

OPERATIONAL CHARACTERISTICS

3 Phase, 400 V, 50 Hz | Type of Operation: S1 (Continuous Operation)
Protection Degree: IP 65 | Insulation Class F (155°C)
Heat Increase Limit: B (80K) | Cooling: TEFC

CAST IRON FRAME

Nominal Power	Type	At Nominal Power							At Start-up				Tilting Moment Ratio	Moment of Inertia	Approx. Weight
		Speed	Current	Torque	Power Coefficient Cos φ	Efficiency η			Current Ratio		Torque Ratio				
		RPM	A	Nm		4/4	3/4	1/2	Direct	Y/Δ	Direct	Y/Δ			

6 poles (1000 RPM)

0,75	GM2Exd 90 S 6	920	2	7,8	0,71	75,9	75,9	72,4	4	-	2,2	-	2,4	0,0034	29,9
1,1	GM2Exd 90 L 6	930	2,9	11,3	0,7	78,1	78,1	75,1	4	-	2,2	-	2,4	0,0044	36
1,5	GM2Exd 100 L 6	945	3,6	15,2	0,75	79,8	79,7	76,4	4,5	-	2,2	-	2,4	0,0077	46,4
2,2	GM2Exd 112 M 6	950	5,4	22,1	0,72	81,8	81,7	78,5	4,7	-	2,2	-	2,5	0,013	58,7
3	GM2Exd 132 S 6	960	7,1	29,8	0,73	83,3	83,2	80,4	4,6	1,5	1,8	0,6	2,3	0,019	80,6
4	GM2Exd 132 M 6a	960	9,3	39,8	0,73	84,6	84,5	81,6	4,7	1,5	2	0,6	2,5	0,024	91,6
5,5	GM2Exd 132 M 6b	960	12,7	54,7	0,73	86	86	83,1	4,9	1,6	2,2	0,7	2,6	0,032	103,2
7,5	GM2Exd 160 M 6	975	16	73,5	0,78	87,2	87,2	84,5	6,3	2	2,6	0,8	3,5	0,076	157,3
11	GM2Exd 160 L 6	970	22,5	108,3	0,8	88,7	88,7	85,7	6,2	2	3	1	3	0,109	181,4
15	GM2Exd 180 L 6	965	29	148,4	0,83	89,7	89,7	86,8	6,5	2,1	2,4	0,8	3	0,2	277,2
18,5	GM2Exd 200 L 6a	980	37,5	180,3	0,8	90,4	90,4	87,7	7,2	2,32	2,3	0,7	3,2	0,234	327,5
22	GM2Exd 200 L 6b	980	43,4	214,4	0,8	90,9	90,9	88,4	6,7	2,3	2,3	0,7	2,8	0,283	353,3
30	GM2Exd 225 M 6	980	58	292,3	0,81	91,7	91,7	89,6	7	2,3	3	1	2,6	0,57	421,6
37	GM2Exd 250 M 6	985	71,4	358,7	0,81	92,2	92,2	90,1	7	2,3	3	1	2,6	0,77	535,1

Efficiency values are calculated by the indirect measurement method in accordance with IEC 60034-2-1: 2014 standard. Additional losses are assessed based on test results performed at variable load values.

SPARE PARTS

Special Series Ex-Proof Motors

FOOT-MOUNTED (B3)

CAST IRON FRAME EX-PROOF MOTORS

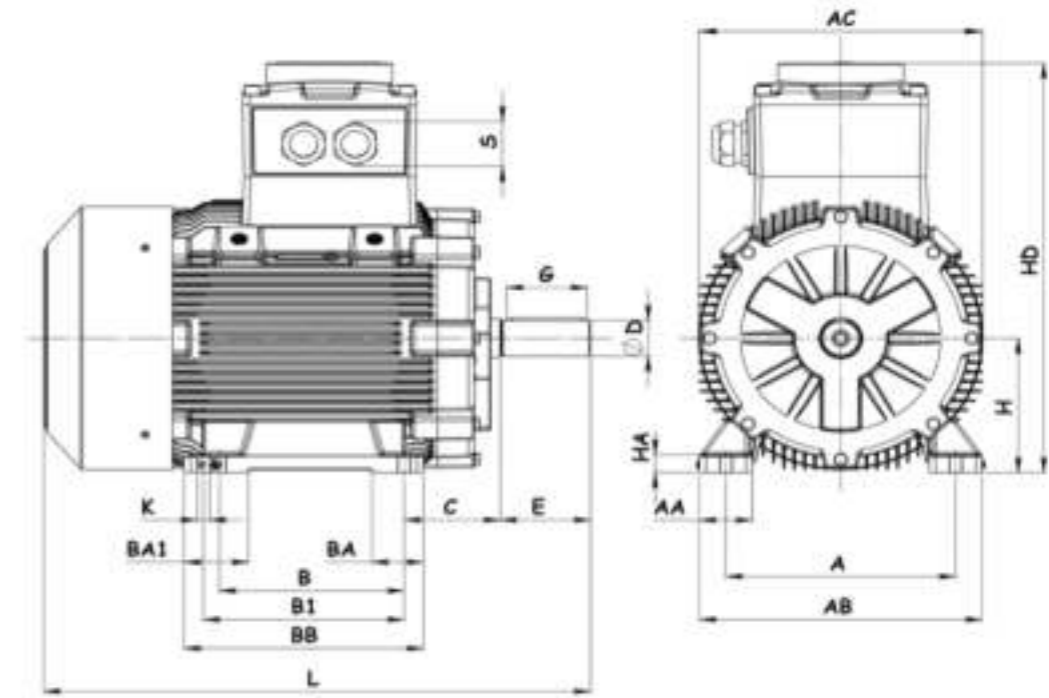
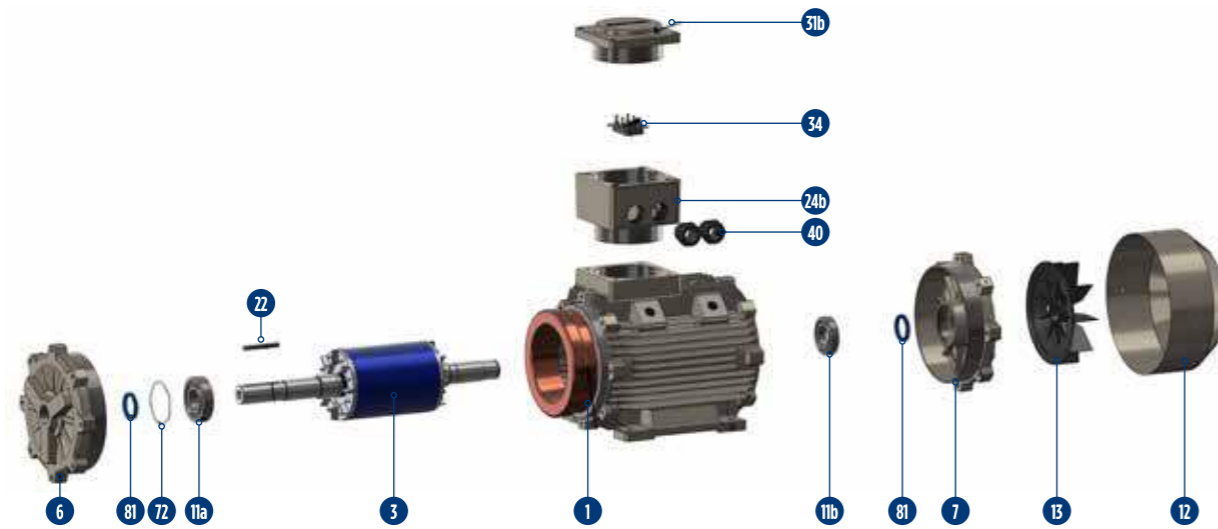

- 1** Stator with Complete Windings: Varnished and installed to the body
- 3** Complete Rotor: With balanced, shaft, machined (excluding keys)
- 6** Front cover
- 7** Rear cover
- 11a** Front Bearing
- 11b** Rear Bearing
- 12** Fan housing wedge
- 13** Fan
- 22** Shaft end wedge
- 24b** End terminal box
- 31b** End terminal box cover
- 34** Terminal
- 40** Cable entry gland
- 72** Disc spring
- 80** Inner snap
- 81** Rubber dust seal (V-ring) or optional oil seal

Type	H	HD	HA	A	AA	AB	AC Ø	K Ø	B	B1	BA	BA1	BB	C	E	D	G Key	S Sleeve
71	71	232	11	112	37	140	138	7	90	-	30	30	120	45	30	14	22	M25x1,5
80	80	250	11	125	36	160	156	10	100	-	27	37	140	50	40	19	32	M25x1,5
90-S	90	270	13	140	42	180	176	10	100	-	30	40	140	56	50	24	40	M25x1,5
90-L	90	270	13	140	42	180	176	10	125	-	37,5	52,5	170	56	50	24	40	M25x1,5
100-L	100	300	16	160	40	200	197	12	140	-	37,5	52	186	63	60	28	50	M25x1,5
112-M	112	312	15	190	47	230	218	12	140	-	49	49	190	70	60	28	50	M25x1,5
132-S	132	401	15	216	51	260	260	12	140	-	50	50	180	89	80	38	70	2 Quantity M32x1,5
132-M	132	401	15	216	51	260	260	12	178	-	50	50	218	89	80	38	70	2 Quantity M32x1,5
160-M	160	471	22	254	65	312	315	15	210	-	72	72	260	108	110	42	90	2 Quantity M40x1,5
160-L	160	471	22	254	65	312	315	15	254	-	72	72	304	108	110	42	90	2 Quantity M40x1,5
180-M	180	556	24	279	74	354	354	15	241	-	75	85	300	121	110	48	100	2 Quantity M40x1,5
180-L	180	556	24	279	74	354	354	15	279	-	80	80	329	121	110	48	100	2 Quantity M40x1,5
200-L	200	611	26	318	79	398	394	19	305	-	80	100	371	133	110	55	100	2 Quantity M50x1,5
225-SM	225	686	30	356	82	438	440	19	286	311	80	100	371	149	140	60	125	2 Quantity M50x1,5
250-M	250	711	35	406	105	484	480	24	349	-	90	90	429	168	140	65	125	2 Quantity M63x1,5

FOOT MOUNTED (B35) CAST IRON EX-PROOF MOTOR

Special Series
Ex-Proof Motors

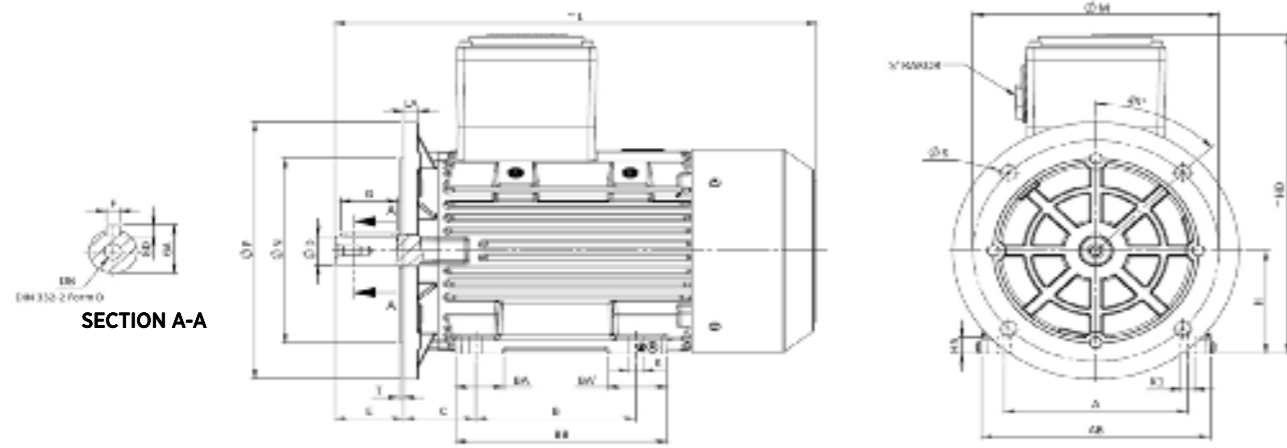

Type	H	HD	HA	A	AA	AB	ØK	K1	B	BA	BA'	BB
71	71	232	11	112	37	140	7	11	90	30	30	120
80	80	270	11	125	36	160	10	15	100	27	37	140
90-S	90	290	13	140	42	180	10	15	100	30	40	140
90-L									125	37.5	52.5	170
100-L	100	310	16	160	46	200	12	18	140	37.5	52	186
100-LH												

Type	Flange No	ØM	ØN	ØP	No	ØS	Cable Gland	T	LA	L -	C	E	DB DC	DØ	GA	FxGD	G
71	FF130	130	110	160	4	10	M25 x1,5	3,5	10	272	45	30	M5	14	16	5x5	22
80	FF165	165	130	200	4	12		3,5	12	320	50	40	M6	19	21,5	6x6	32
90-S	FF160	165	130	200	4	12	M25 x1,5	3,5	12	339	56	50	M8	24	27	8x7	40
90-L					4					369							
100-L	FF215	215	180	250	4	14,5	M25 x1,5	4	15	421	63	60	M10	28	31	8x7	50
100-LH					4					471							



EX-PROOF MOTORS

SPECIAL
SERIES

”
CRUSHER
MOTORS
“

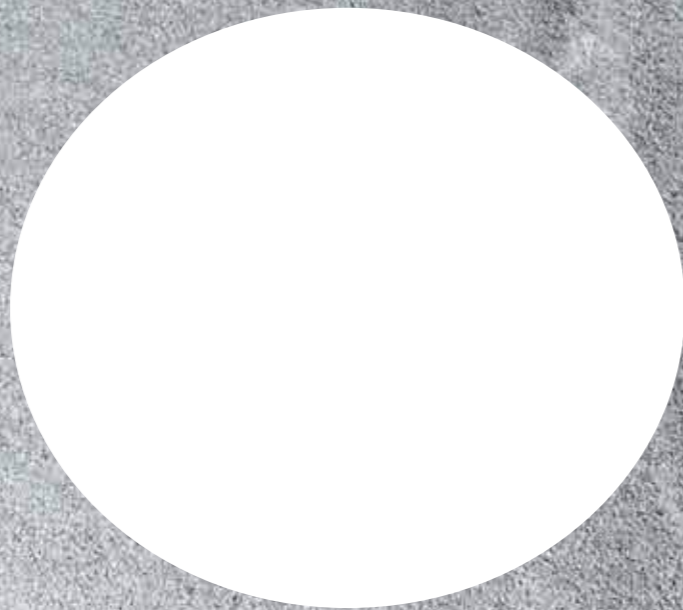

Gamak crusher motors are designed to withstand the heavy operating conditions required by the industry from 132 kW to 355 kW in 315 and 355 types. Crusher motors designed in fixed base cast iron bodies can also be supplied attachable feet housings in 315 types with HT code structure upon request.

IP65 protection, which is especially needed in extremely dusty environments, is provided with a special seal and bearing design. Standard features include lubricated NU bearing used in the pulley shaft output, Class H insulation, shaft design with increased resistance to excessive fatigue and torsion (shaft diameter 100 millimeters), impact and drop resistant cast iron body structure, thermistor protection. Thanks to its electrical design suitable for working with the driver, it also responds to speed control needs. The following are the basic application areas for the motor:

- Stone Crushing
- Feeders and Feeder Conveyors
- Crushers
- Sieves
- Demolishers
- Vibration

CRUSHER MOTORS - TECHNICAL CHARACTERISTICS HIGH EFFICIENCY MOTORS

IE2

OPERATIONAL CHARACTERISTICS

3 Phase, 400 V, 50 Hz | Type of Operation: S1 (Continuous Operation)
 Protection Degree: IP 65 | Insulation Class H (180°C)
 Heat Increase Limit: B (80K)

CAST IRON FRAME

Nominal Power	Type	At Nominal Power							At Start-up				Tilting Moment Ratio	Moment of Inertia	Approx. Weight
		Speed	Current	Torque	Power Coefficient Cos φ	Efficiency η			Current Ratio		Torque Ratio				
kW		RPM	A	Nm		4/4	3/4	1/2	Direct	Y/Δ	Direct	Y/Δ			

4 poles (1500 RPM), with Fixed Feet Housing

132	GM2E 315 M 4b	1485	230	848,9	0,87	94,7	94,5	93,8	7,4	2,5	2,1	0,7	3	2,5	861
160	GM2E 315 M 4c	1485	280	1029	0,87	94,9	94,9	94	7	2,3	2	0,7	2,9	2,8	882
185	GMM2E 315 L 4d	1485	323	1189,7	0,87	95,1	95,1	94,2	7,4	2,5	2,2	0,7	3	2,9	962
200	GMM2E 315 L 4e	1485	350	1286,2	0,87	95,1	95,4	94,2	8	2,7	2,5	0,8	3	3,1	1015
250	GM2E 315 H 4f	1485	425	1607,1	0,89	95,1	95,1	94,2	8,1	2,7	2,3	0,8	3	3,5	1200
250	GMM2E 355 M 4a	1485	445	1607,7	0,85	95,1	95,1	94,2	6,4	2,1	2,1	0,7	2,8	5,5	1378
315	GMM2E 355 M 4b	1490	560	2019	0,85	95,1	95,1	94,5	6,4	2,1	2	0,7	2,8	6	1400
355	GMM2E 355 M 4c	1490	630	2275,3	0,86	95,1	95,4	94,2	7	2,3	2	0,7	2,8	6,5	1438

Attachable Feet Housings, 4 poles (1500 RPM)

185	GM2E 315 HT 4d	1485	323	1189,7	0,87	95,1	95,1	94,2	7,4	2,5	2,2	0,7	3	2,9	1040
200	GM2E 315 HT 4e	1485	350	1286,2	0,87	95,1	95,4	94,2	8	2,7	2,5	0,8	3	3,1	1150
250	GM2E 315 HT 4f	1485	425	1607,1	0,89	95,1	95,1	94,2	8,1	2,7	2,3	0,8	3	3,5	1200



Efficiency values are calculated by the indirect measurement method in accordance with IEC 60034-2-1: 2014 standard. Additional losses are assessed based on test results performed at variable load values.

CRUSHER MOTORS - TECHNICAL CHARACTERISTICS HIGH EFFICIENCY MOTORS

Crusher Motors

IE3

OPERATIONAL CHARACTERISTICS

3 Phase, 400 V, 50 Hz | Type of Operation: S1 (Continuous Operation)
 Protection Degree: IP 65 | Insulation Class H (180°C)
 Heat Increase Limit: B (80K)

CAST IRON FRAME

Nominal Power kW	Type	At Nominal Power						At Start-up				Tilting Moment Ratio	Moment of Inertia	Approx. Weight	
		Speed	Current	Torque	Power Coefficient Cos φ	Efficiency η			Current Ratio		Torque Ratio				
		RPM	A	Nm		4/4	3/4	1/2	Direct	Y/Δ	Direct				Y/Δ

4 poles (1500 RPM), with Fixed Feet Housing

132	GM3E 315 M 4b	1490	226	846	0,88	95,6	95,4	95,3	7,4	2,5	2,4	0,8	3	2,8	882
160	GM3E 315 L 4c	1490	275	1025,5	0,88	95,8	95,6	95,6	6,9	2,3	2,2	0,7	2,9	3	930
185	GMM3E 315 L 4d	1490	321	1185,7	0,87	96	96	95,8	6,9	2,3	2,2	0,7	2,9	3,1	1015
200	GM3E 315 H 4e	1490	350	1281,9	0,86	96	95,8	95,8	7,5	2,5	2,5	0,8	3,1	3,3	1100
250	GM3E 315 H 4f	1490	435	1602,3	0,86	96	95,8	95,8	7,6	2,5	2,3	0,8	3,1	3,5	1200
250	GMM3E 355 M 4a	1490	430	1602,3	0,87	96	96	96	7,2	2,4	2,2	0,7	3	6	1400
315	GMM3E 355 M 4b	1490	540	2019	0,88	96	96	95,9	7,2	2,4	2,2	0,7	3	6,5	1438

Attachable Feet Housings, 4 poles (1500 RPM)

160	GM3E 315 HT 4c	1490	275	1025,5	0,88	95,8	95,6	95,6	6,9	2,3	2,2	0,7	2,9	3	980
185	GM3E 315 HT 4d	1490	321	1185,7	0,87	96	96	95,8	6,9	2,3	2,2	0,7	2,9	3,1	1040
200	GM3E 315 HT 4e	1490	350	1281,9	0,86	96	95,8	95,8	7,5	2,5	2,5	0,8	3,1	3,3	1150
250	GM3E 315 HT 4f	1490	435	1602,3	0,86	96	95,8	95,8	7,6	2,5	2,3	0,8	3,1	3,5	1200

Crusher Motors

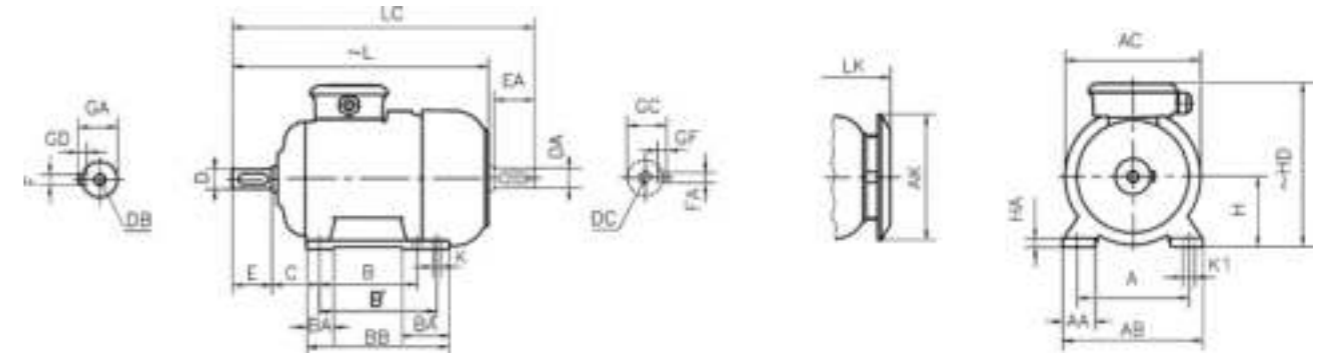

Sizes of foot mounted motor: Frame Forms B3, B6, B7, B8, B15, V5, V6																									
Frame Size	No of Poles	H	HD-	HA	A	AA	AC	ACØ	AKØ	K	B	B'	BA	BA'	BB	L-	LC	LK-	C	EEA	DB DC	DØ DAØ	GA GC	FxGD FxGF	
315	M	315	825	50	508	125	620	614	571	28	406	-	115	166	550	1150	1330	1227	216	210	M24	100	106	28x16	
	L										-	457	125	-	600	1220	1400	1297	228						
	HT/H										508	-	150	-	600	1381	1561	1297	228						
355	M	355	980		610	150	740	732			560	-	140	-	680	1377	1597	1454	254						

Efficiency values are calculated by the indirect measurement method in accordance with IEC 60034-2-1: 2014 standard. Additional losses are assessed based on test results performed at variable load values.

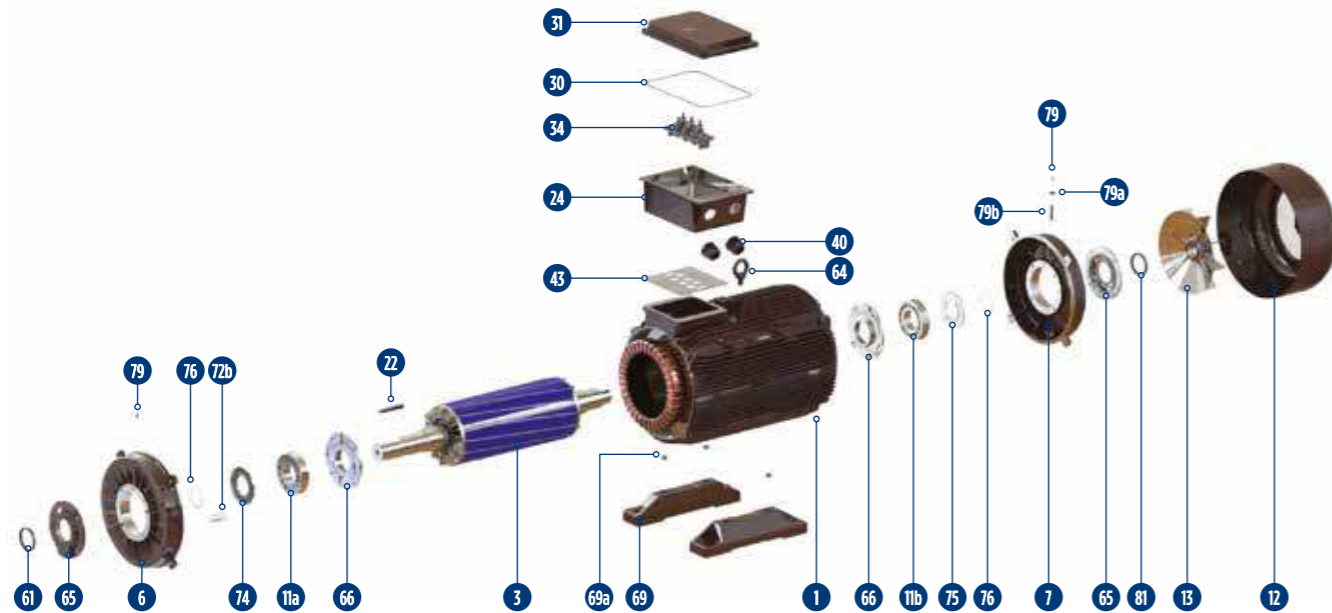

- 1 Stator with Complete Windings: Varnished and installed to the body
- 3 Complete Rotor: With balanced, shaft, machined (excluding keys)
- 6 Front cover
- 7 Rear cover
- 11a Front bearing (Cylindrical Roller)
- 11b Rear bearing
- 12 Fan housing (63...450)
- 13 Cooling fan
- 22 Shaft end wedge
- 30 Seal (Between terminal box and cover)
- 31 Terminal box cover
- 34 End plate - Terminal (including bridge, nuts and washers)
- 40 Cable entry gland
- 43 Seal (between end terminal box and motor frame)
- 64 Lifting eye (200...450)
- 65 Bearing holder outer cover (for motors with lubrication nipple)
- 66 Bearing holder inner cover (for motors with lubrication nipple)
- 69 Attachable feet housings
- 69a Centering bush
- 72b Coil spring (315...450)
- 75 Oil retaining disc (for motors with lubrication nipple)
- 76 Outer snap ring; For fixing the bearing and oil holding disc
- 79 (For motors with lubrication nipple at the front and rear, 160...280 at the rear)
- 79a Greaser pipe holder
- 79b Greaser spacer
- 81 Rubber dust seal (V-ring) or optionally oil seal
- 81 Rubber dust seal (V-ring) or optionally oil seal



SPECIAL
SERIES

MILKING MACHINE MOTORS

“

Gamak Milking Machine Motors are designed to withstand the operating conditions required by the industry, with Type 90, from 0.55 kW to 1.5 kW, with a permanent circuit capacitor at 1500 RPM. Milking motors designed in aluminum bodies with Fixed Feet Housing can be manufactured with special cut-off shaft and switch upon request. To achieve maximum performance on the vacuum pumps coupled to the milking machine motors, maximum attention is paid to the axial elongation of the shaft and the sensitivity on the flange surface.

OPERATIONAL CHARACTERISTICS

1 Phase, 220 V, 50 Hz | Type of Operation: S1 (Continuous Operation)
Protection Degree: IP 55 | Insulation Class F (155°C) Heat Increase Limit: B (80K)

Special Milking Machine Motors with Permanent Circuit Capacitors

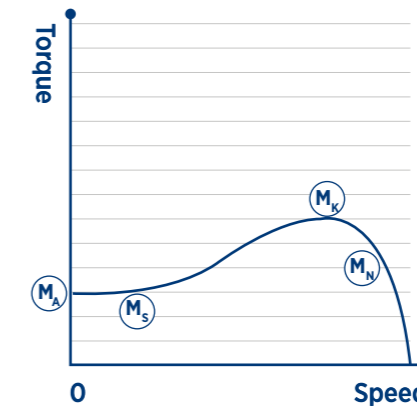
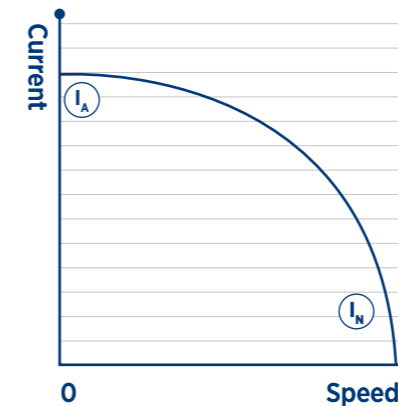

1 Phase, 220 V, 50 Hz
Operation Type S1 (Continuous Operation)
Protection Degree IP 55
Insulation Class F (155 °C)
Heat Increase Limit B (80 K)

Nominal Power	Type	At Nominal Power					At Start-up		Tilting Moment Ratio	Permanent Circuit Capacitor	Moment of Inertia J	Approx. Weight
		Speed	Current	Torque	Power Coefficient	Efficiency	Current Rate	Torque Ratio				
kW		RPM	A	Nm	Cos φ	%	I _A / I _N	M _A / M _N	M _K / M _N	μF	kgm ²	kg

Fixed Feet Housing 4 poles (1500 RPM)

0,55	MD.F 90 S 4e	1410	4,8	3,8	0,79	63	3,2	0,5	1,9	25	0,00076	11,6
0,75	MD.F 90 S 4g	1410	5,1	5,1	0,91	70	3,6	0,5	1,9	30	0,00160	13,6
1,1	MD.F 90 S 4c	1400	7,1	7,5	0,95	74	4,4	0,4	1,8	35	0,00209	16,8
1,5	MD.F 90 L 4d	1420	10,2	10,1	0,92	73	4,2	0,4	1,9	50	0,00265	19,1

Different options of motors can be provided according to customer requests.

Fixed Feet Housing 4 poles (1500 RPM)

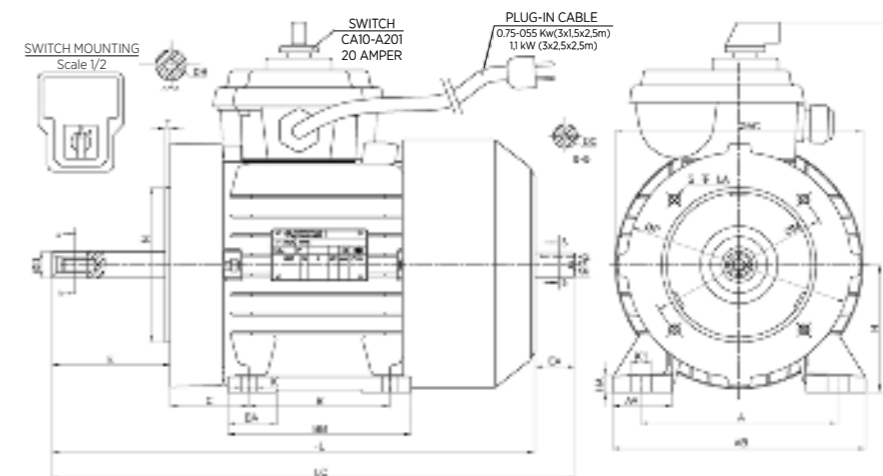

Sizes of foot mounted motor: Frame Forms B3, B6, B7, B8, B15, V5, V6

Frame Size	No of Poles	H	HD	HA	A	AA	AB	ØAC	ØAK	K	K1	B	B'	BA	BA'	BB	Flans No	ØM	ØN	ØP	S	T	LA	L-	LC	C	E	EA	DB	DC	ØD	ØDA
90-S	4	90	260	12	140	43	180	176	-	10	15	100	-	35	-	130	FT130	130	110	160	MB	3,5	16	332 343	361 372	343	73 84	29	M10	3,15	19 22	17

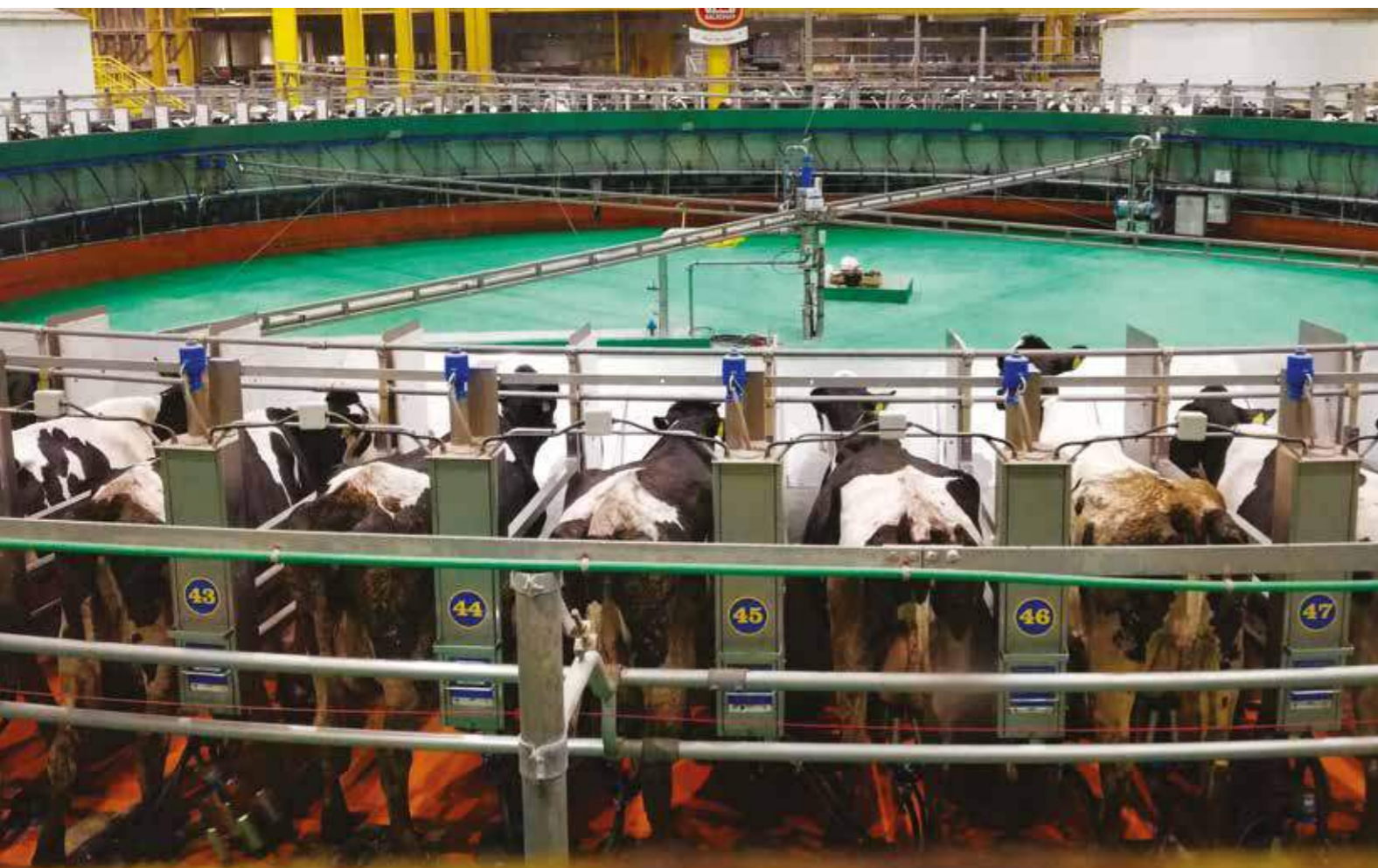

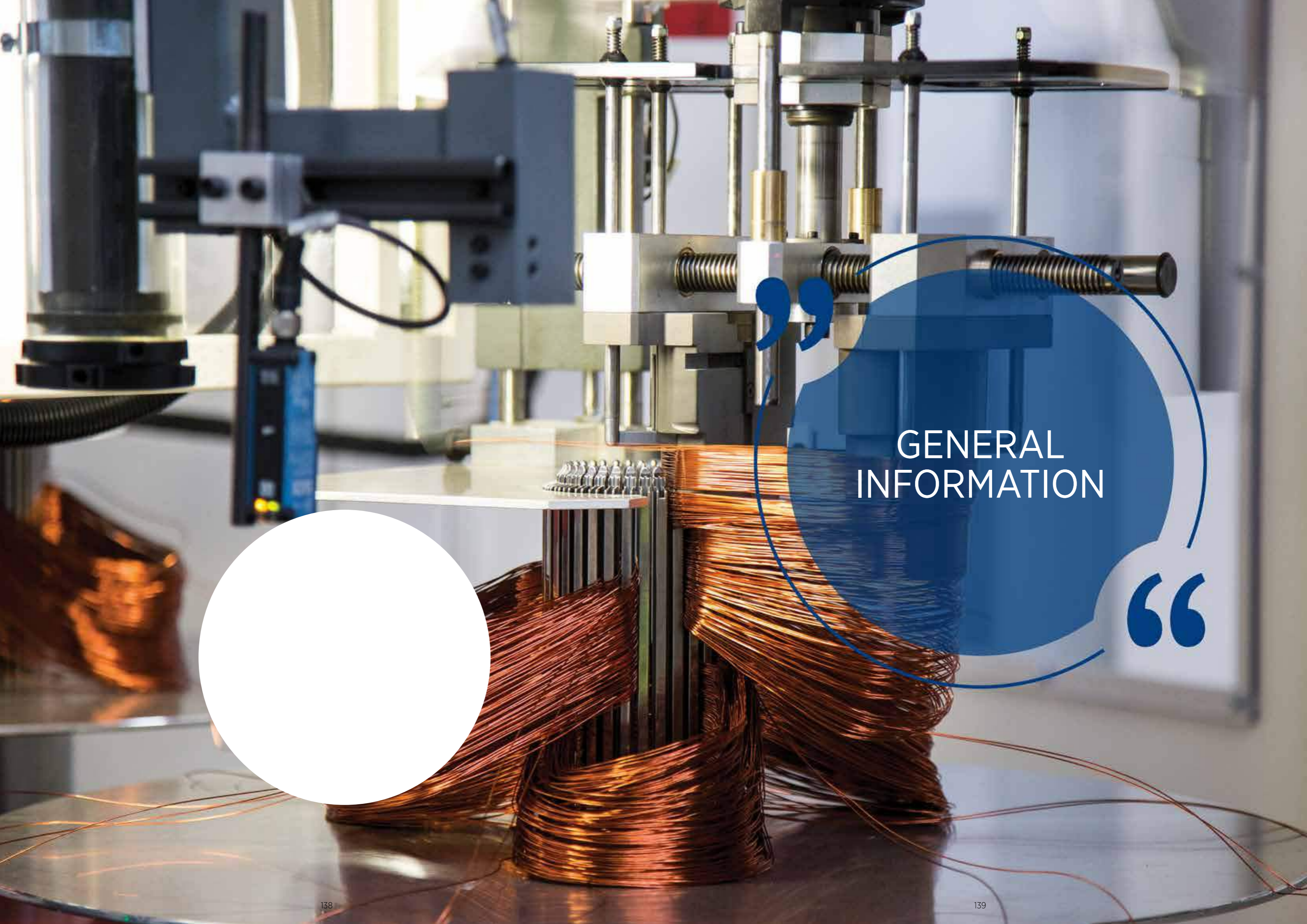

GENERAL
INFORMATION

“

Speed Control Applications

Static frequency converters are electronic devices that allow adjustment of the speed of caged asynchronous motors in a wide range with the variable frequency and voltage power supply they provide. Stepless and practically lossless speed adjustment of a caged asynchronous motor can be achieved when fed with a suitably designed frequency converter. Two different methods are used in frequency converters to control the line voltage reaching the motor by switching: PAM (Pulse Amplitude Modulation = Pulse amplitude modulation) and commonly used PWM (Pulse Width Modulation). The alternating current reaching the motor is first converted to the direct current, then the direct current is sliced in the PWM method and a three-phase output voltage is created in the PAM method without applying slicing.

Speed Adjustment for Caged Asynchronous Motors

Today, cage asynchronous motors whose speed is adjusted by frequency converters are used in all types of facilities and with all types of automated equipment. The main benefits of lossless speed adjustment in a wide range include energy savings, process and quality improvement. Calculations and measurements so far have shown that the best operating properties in common speed ranges are provided by the 4-pole asynchronous motors. Therefore, this number of poles should be preferred in practice. However, other pole quantities may be selected when very low or high speeds are required. The motor nominal voltage is normally taken equal to the mains voltage so that the motor can be fed directly from the network when the frequency converter fails. Asynchronous motors used with frequency converters are of standard construction, but specially designed motors may be required at large powers. The common feature of all frequency converters is that motor losses increase compared to direct supply from the network. Due to this increase in voltage and current caused by the presence of harmonics, an asynchronous motor fed from a frequency converter may not be able to deliver its rated power. In practice, it would be appropriate to reduce the nominal power between 0-20%, following the IEC Recommendation. In selecting the derating factor for a particular motor, the temperature reserve of that motor should be considered. (see IEC 60034-17: Application Guide for caged asynchronous motors powered by frequency converter).

Insulation systems of asynchronous motors fed from frequency converter may have higher difficulty than supply from mains due to high voltage increase rate and possibility of occurrence of high instantaneous voltages. This forced increase depends on the frequency of the frequency converter and the cable length between the frequency converter and the motor as well as the leakage reactance of the motor. Therefore, issues to analyze include cable length, filter requirement and, in some cases, and the use of special insulation systems. In practice, the cable length should be kept as short as possible, so asynchronous motors integrated (wireless direct connection) with frequency converters included in the Gamak manufacturing program are recommended for variable speed applications.

This design should be avoided, especially in large motors, since double cage or deep grooved rotor construction causes high harmonic losses. Since the motor does not need to have high starting torque when supplied from a frequency converter, different cage designs may be more suitable. However, one should keep in mind that direct start is not guaranteed, especially in drives with constant torque, since asynchronous motors with special cage rotors will be supplied directly from the network in case of frequency converter failure. On the other hand, an asynchronous motor fed from a frequency converter may generate more noise due to harmonics than a mains supply. With proper motor and frequency converter design, this noise can be reduced.

Another effect of the supply from the frequency converter is that voltages can be induced at the motor shaft. If these voltages rise significantly, the resulting currents can damage the bearings and cause premature failure. Although this type of failure is rare, insulation can be provided by the drive-in side of the bearings for operational safety. For detailed information, please see Page 60 Shaft voltages.

Operation Below and Above Nominal Speed in Speed Control Applications

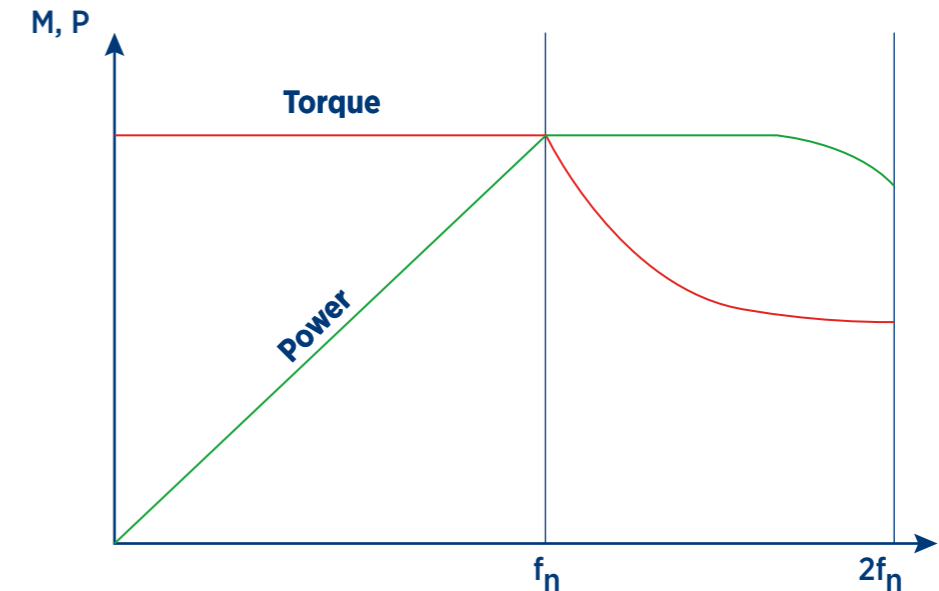

The curve above shows how engine power and torque vary above and below the engine nominal speed. As seen from the curve, it is possible to obtain constant torque from motors below the nominal speed. If it is above the nominal speed, constant power can still be obtained; however, the field weakening that is approximately above 85 Hz will increase the losses, causing a decrease in power.

Operating Below Nominal Speed

If the supply voltage is reduced proportionally to the frequency when the frequency is decreased, the magnetic flux of the motor can be loaded at a constant torque. If the torque is kept constant, the current and power factor do not change. To ensure that the torque does not fall at low frequencies, the voltage must take a larger value than being proportional to the frequency. So, the voltage drop in the stator resistance is compensated. In load applications that require variable torque, such as centrifugal pumps and fans, where the torque decreases with speed, it should be taken into account that the voltage should be less than the proportional value to the frequency when choosing a frequency converter. At low speeds, the cooling air induced by the motor fan decreases in proportional to the speed. In applications requiring constant torque, the heat generated in the motor does not change since the magnetic flux will remain constant when the speed decreases, so the cooling air of the fan will not be enough. The heat generated in the motor cannot be completely removed, and the reduction of iron losses at low speeds cannot fully compensate for the negativities caused by insufficient cooling. In this case, it may be necessary to reduce the output of the motor or consider forced (independent) cooling.

Encoder Usage

It can be requested to use an encoder for closed loop control due to the need of constant torque and precise speed adjustment at very low speeds. If an encoder is requested, the rear shaft output is specially manufactured and the encoder is mounted. We use hollow shaft encoders, and the user must determine the technical details of the encoder, and if requested, we supply the encoder, or the user supplies it or we mount the encoder supplied by the user onto the motor.

Major Issues to Consider in Encoder Selection It is as follows:

- No of signals (puls)
- Mechanical size (hollow shaft encoder)
- Supply voltage
- Signal type

In addition, it may be necessary to use ceramic coated bearings against shaft stresses in encoder bearings as well as in motor bearings in large-power motor applications. Since there is a need for encoders at low speeds in general, forced cooling is also required in motors with encoders. The illustration below shows the motor assembled with encoder + forced cooling kit can be seen. Although the total lengths (“L” dimension) of the motors with encoders vary with an encoder type and dimensions, they increase by approximately 100 mm compared to the standard motors.

Forced Cooling Kit

The illustration below shows the connection method of the forced cooling kit that works continuously independent of the motor shaft. The table shows the total lengths of the motors with the forced cooling kit.

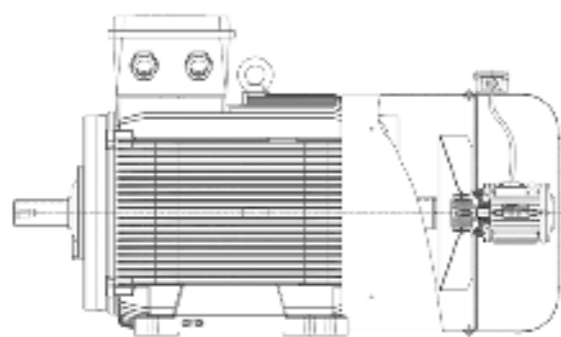

Frame Size	No of Poles	L (mm)	Frame Size	No of Poles	L (mm)	Frame Size	No of Poles	L (mm)
71	2-4-6-8	372	132	S	2-4-6-8	315	2	1405
				M			4-6-8	1435
80	2-4-6-8	406	160	L	2-4-6-8	M	2	1405
				M			4-6-8	1435
90	S	444	180	L	2-4-6-8	L	2	1435
	L	469					4-6-8	1475
100	L	522	200	L	2-4-6-8	M	2	1505
				S	4-8		4-6-8	1617
112	M	537	225	M	2	355	2	1657
					1093		4-6-8	1687
132	S	607		4-6-8	118	L	2	1727
	M	645	250	M	2	400	4-6-8	1944
160	M	831		4-6-8	1150	M	2	1944
	L					450	4-6-8	1984
180	M	904	280	S	2			
	L			4-6-8				
200	L	1021		M	2			
				4-6-8	1219			

Note: Please consult for 450 LH body.

Operating Above Nominal Speed

Since frequency converters cannot deliver a voltage greater than the mains voltage in general, the motor magnetic field and flux weaken as the voltage/frequency ratio decreases when the frequency rises above the nominal value, so the motor can give the nominal power above the nominal speed, but the rotation torque decreases. Depending on the tilting moment in rated operation, the motor can be run at constant power up to the speed at which the power starts to decrease. At higher frequencies, severe field weakening increases slipping, which then increases copper losses, in addition, the skin effect that causes heat loss in the grooves may start to create a detrimental effect. Although the losses occurring at high speeds cause the motor power to be limited to the nominal value, the maximum allowable speed of the motor is determined by other factors.

- **Tilting Moment:** It decreases with the increasing frequency.
- **Bearing design:** Due to the vibrations that increase above the nominal speed, the mechanical stress of the bearings increases and the life of the bearings and grease decreases. In such a case, it is recommended that the rotors be balanced to the S (special) grade (DIN EN 60 034-14).

• **Fan design:** The motor cooling fan must be of mechanical strength to withstand increasing centrifugal forces. Normally, shaft mounted cooling fans are only suitable up to a frequency of 60 Hz. Furthermore, fan noise intensifies with increasing speed in self-cooling motors. These drawbacks can be avoided by using forced (independent) cooling.

2 poles (3000 RPM)

Power (kW)	Frame Size	Mechanical Limit Speed (RPM)	Maximum Operating Speed (RPM)
0,09...5,5	56...112	6000	100
5,5...11	132	5600	90
11...22	160	4800	80
22 - 30	180	4600	76
30...55	200 - 225	4500	75
55...500	250 - 355	3600	60
450...1000	400 - 450	3400	56

4 poles (1500 RPM)

Power (kW)	Frame Size	Mechanical Limit Speed (RPM)	Maximum Operating Speed (RPM)
0,06...11	56 - 132	4200	140
11...55	160 - 225	4200	140
55...110	250 - 280	3600	120
110...250	315	2800	93
250...500	355	2400	80
450...1000	400 - 450	2200	73

6 poles (1000 RPM)

Power (kW)	Frame Size	Mechanical Limit Speed (RPM)	Maximum Operating Speed (RPM)
0,18...5,5	71...132	3900	195
7,5...15	160...180	3600	180
18,5...37	200...225	3200	160
37 - 75	250 - 280	3000	150
75...160	315	2600	130
160...355	355	2400	120
355...8000	400	2200	110

8 poles (750 RPM)

Power (kW)	Frame Size	Mechanical Limit Speed (RPM)	Maximum Operating Speed (RPM)
0,09...11	71...180	3200	213
15...45	200...280	3000	200
55...132	315	2600	173
132...315	355	2400	160
315...630	400 - 450	2200	147

Shaft Voltages:

Another problem that can be encountered in motors of 400 kW and above (although in theory 110kW and above, in practice, larger powers are encountered) is the shaft voltages formed on the motor body. Due to the asymmetrical structure created by the speed control device in the motor flux, currents occur in the motor body and these currents pass over the bearings and complete the circuit. Currents flowing over the bearings may cause the bearings to deteriorate over the time. The most effective method to prevent this is to use an insulated bearings. In this case, precautions should be taken by insulating the rear bearing bearings of the motor or by using isolated bearings. If requested, we can manufacture Gamak insulated bearing (isolated cover or isolated bearing) motors.

Important Note:

Due to the common mode voltages at the output of the speed controller, there is a risk of capacitive discharge current in motors with a power below 110kW. The most effective method of preventing capacitive discharge current is to make proper grounding as specified in the IEC 60034-25 standard and, if possible, to place a common-mode filter at the output of the drive.

The relation of narrow V-belt pulleys with asynchronous motors is given in DIN 2211. Since the radial load applied by the pulleys of the following dimensions to the motor shaft end is within the radial force limit specified for the respective motor, they are recommended for GAMAK motors. The shape of the pulleys may differ from those shown in the illustration, but the dimensions are as given in the chart.

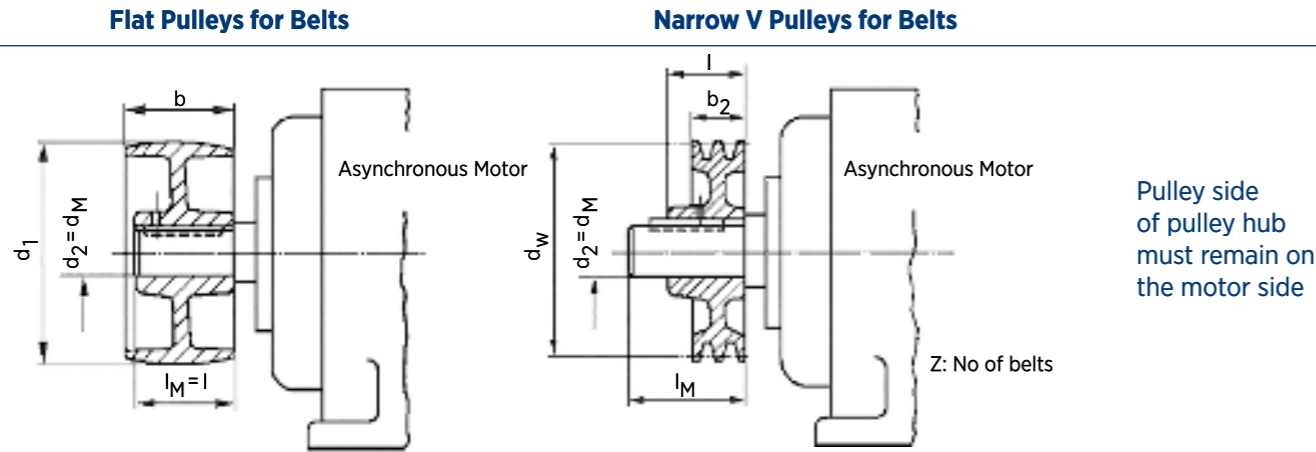

Flat Belt Pulleys DIN111			Three Phase Asynchronous Motor Power Pn in kW at 50 Hz Motor speed RPM					Narrow V Belt Pulleys DIN 2211 T1					
d ₁	b	l	3000	1500	1000	750	Frame Size	Shaft End d _M xl _M	Profile	d _w	Z	b ₂	l
50	25	23	0,18	0,12	-	-	63	11x23	-	-	-	-	-
			0,25	0,18	-	-							
63	32	30	0,37	0,25	-	-	71	14x30	-	-	-	-	-
			0,55	0,37	-	-							
80	40	40	0,75	0,55	0,37	-	80	19x40	-	63	1	16	28
			1,1	0,75	0,55	-							
100	50	50	1,5	1,1	0,75	-	90 S	14x50	SPZ	71	1	16	28
125	63		2,2	-	-	-	90 L						
160	80	60	-	1,5	1,1	-	100 L	28x60	SPZ	100	1	16	40
			3	-	-	0,75							
160	80	60	-	2,2	1,5	1,1	112 M	28x60	SPZ	112	2	28	40
			-	3	-	-							
200	100	80	4	-	-	-	132 S	38x30	SPZ	140	2	28	40
			-	4	-	-							
224	100	80	-	-	-	-	132 M	38x30	SPZ	140	3	40	50
			-	7,5	5,5	-							
250	125	110	11	-	-	4	160 M	42x110	SPZ	160	3	40	50
			15	11	7,5	5,5							
280	140	110	18,5	15	11	7,5	160 L	48x110	SPZ	180	4	52	52
			22	-	-	-							
315	160	110	-	18,5	-	-	180 M	48x110	SPA	180	4	65	65
			-	22	15	11							
315	200	110	30	-	-	-	200 L	55x110	SPA	200	4	65	65
			37	-	-	-							
355	200	140	-	30	18,5	15	225 S	60x140	SPA	250	5	80	70
			-	37	-	-							
355	200	140	45	-	-	-	225 M	60x140	SPB	280	4	82	82
			-	45	30	22							
400	200	140	55	-	-	-	250 M	60x140	SPA	250	5	80	70
			-	55	37	30							
450	224	140	*75	-	-	-	280 S	65x140	-	-	-	-	-
			-	75	45	37							
450	224	140	*90	-	-	-	280 M	65x140	-	-	-	-	-
			-	90	55	45							
500	250	170	*110	-	-	-	315 S	65x140	-	-	-	-	-
			-	110	75	55							
500	250	170	-132	-	-	-	315 M	65x140	-	-	-	-	-
			-	132	110	75							
500	250	170	-	-	-	-	315 M	85x170	SPC	400	6	161,5	120
			-	-	-	-							

The following efficiency (η) and power coefficient ($\text{Cos } \varphi$) are used in relation to the operating values. The listed values are average values. Please consult for exact values of a specific motor.

% Efficiency (η)					Power Coefficient ($\text{Cos } \varphi$)				
1/4	1/2	3/4	4/4	5/5	1/4	1/2	3/4	4/4	5/5
92	94,5	96	96	95,5	0,70	0,86	0,91	0,92	0,93
90	93,5	95	95	94,5	0,65	0,84	0,90	0,91	0,92
89	92,5	94	94	93,5	0,63	0,83	0,89	0,90	0,91
88	91,5	93	93	92,5	0,61	0,80	0,88	0,89	0,90
87	91	92	92	91,5	0,57	0,78	0,86	0,88	0,89
86	90	91	91	90	0,53	0,76	0,85	0,87	0,87
85	89	90	90	89	0,51	0,75	0,84	0,86	0,86
84	88	89	89	88	0,49	0,73	0,83	0,85	0,86
80	87	88	88	87	0,47	0,71	0,81	0,84	0,85
79	86	87	87	86	0,45	0,69	0,80	0,83	0,84
78	85	86	86	85	0,43	0,67	0,79	0,82	0,83
76	84	85	85	83	0,41	0,66	0,77	0,81	0,82
74	83	84	84	82	0,40	0,65	0,76	0,80	0,81
72	82	83	83	81	0,38	0,63	0,75	0,79	0,80
70	81	82	82	80	0,36	0,61	0,74	0,78	0,80
68	80	81	81	79	0,34	0,59	0,72	0,77	0,79
66	79	80	80	78	0,32	0,58	0,71	0,76	0,78
64	77	79	79	77	0,30	0,56	0,69	0,75	0,78
62	75	78	78	76	0,29	0,55	0,68	0,74	0,77
60	74	77	77	75	0,28	0,54	0,67	0,73	0,76
58	73	76	76	74	0,27	0,52	0,63	0,72	0,76
56	72	75	75	73	0,26	0,50	0,62	0,71	0,76
55	71	74	74	72	0,25	0,49	0,61	0,70	0,75
54	70	73	73	71	0,24	0,48	0,59	0,69	0,74
53	68	72	72	70	0,23	0,47	0,58	0,68	0,74
52	67	71	71	69	0,23	0,46	0,57	0,67	0,73
51	66	70	70	68	0,22	0,45	0,56	0,66	0,72
50	65	69	69	67	0,22	0,44	0,55	0,65	0,71
49	64	68	68	66	0,22	0,43	0,54	0,64	0,70

Transport

Motors must be lifted with lifting eyes. The capacity of the hoist used should be at least the motor weight. For the weight of the motor, see the pages on the operating values of the relevant motor. When carrying a motor group with the fixing plate, never lift it with the motor lifting eye. In this case, the lifting eyes of the fixing plate should be used. If the motors have cylindrical roller or angular contact ball bearings, a locking device is provided to prevent the bearings from being damaged during transport. This arrangement must be removed definitely before the motors are put into operation.

Ventilation and Cooling

On the plastic fans of the motors, two opposite latches injected together with the fan enter the circumferential groove on the shaft and fix the propeller in the axial direction. Again, the wedge injected together with the plastic fan detects the fan in the radial (rotation) direction. In order to dismantle the fans, the latches should be removed from the groove and kept in the open position with the flat sheet support inserted into the rail. Suitable tools should always be used when installing or removing the fans. The distance between the cooling air intake and the wall or other machinery should be at least one quarter of the air inlet diameter. The hot exhaust air of the motor must not be sucked back for cooling. Vertically installed motors with air intake at the top should be protected with a special additional cover and water and foreign objects should be prevented from entering the motor (See Page 88 Part No.: 82 Canopy). The vents of the fan housing cover should be cleaned regularly when necessary. For this purpose, oil-free compressed air should be blown to the outside of the motor.

Water Drain Holes

The water drain holes clogged with plastic plugs are located at the lowest point of the flange or cover according to the design and installation arrangement of the motor and must be kept clean at all times. If the plugs are removed, the protection degree of the motor enclosure becomes IP 44.

Elimination of Parasites

Motors are manufactured in G interference degree according to VDE 0875. This degree of interference is adequate for industrial applications. If N (Normal) or A (Low) noise levels are required for the residential areas, it is recommended to make noise measurements at the place of use and take appropriate remedial measures.

Installation

Motors must be installed on a flat and vibration-free foundation. All foot mounted motors must sit with their full surfaces. Under unfavorable operating conditions, the temperature of the body parts may rise up to 100°C or even exceed it. These parts must not be touched and/or prevented from being touched. Temperature sensitive parts such as normal cables and electronic components should not be placed or touched on the hot part of the body.

Alignment

Motors must always be precisely aligned. More attention should be paid to this, especially when they are directly connected to the work machine. Misalignment can cause bearing failure, vibration, and even shaft breakage. As soon as bearing failure or vibration is detected in a motor, the alignment should be checked. While the motor is connected to the work machine, the shafts must be aligned radially and angularly with the help of a dial indicator. For this, both coupling halves are rotated 90° together, and measurements are made at four points. It is recommended to recheck the alignment after the machines have reached thermal equilibrium.

Transmission Concepts and Balancing Pulleys

If the couplings and pulleys used apply radial or axial shaft loads during operation, the catalog values of the allowed mechanical forces should not be exceeded. Only flexible couplings should be used as rigid couplings require a special bearing design. Transmission elements should be installed and removed using only suitable tools. No pressure or impact should be applied to the bearings. Statistics show that around 70% of motor failures are caused by bearing breakdowns. Most bearing failures are also caused by incorrect mounting of the coupling or pulley. If a belt drive is used, the motor must be fixed to the fixing rails to properly adjust the belt tension. The shafts should be parallel, the pulleys in line and a tensioner on the belt bottom side. Excessive tensioning of the belt can damage the shaft and bearings. For the selection of belt pulleys, please see page 114.

Balance

The rotors are dynamically balanced with the HALF WEDGE placed on the shaft end. Therefore, shaft elements such as coupling, pulley or fan mounted on the shaft end must be balanced on a straight mandrel before the key way is opened. A protective cover is placed at the end of the shaft to prevent it from falling during transportation. If the rotor, transmission couplings, etc. elements are to be operated before they are attached to the shaft end, the necessary precautions should be taken to prevent the wedge from popping out by fixing it securely to the shaft end.

Insulation Resistance

The insulation resistance of newly built or newly wound motors is normally very good. However, under unfavorable transportation, storage or stopping conditions, moisture and/or dirt can reduce the insulation resistance to an undesirably low level. Before an electric motor is put into operation for the first time or after a long storage or downtime, the insulation resistance of the windings must be measured. The measurement is made by applying 500V DC and approximately one minute later the final resistance value is read. During or immediately after the measurement, terminals under dangerous voltage should not be touched. Also, if the supply cables are connected, make sure that the circuit is clearly cut. This warning applies to both primary and auxiliary circuits, and especially to anti-condensation heating circuits. Although a limit value cannot be stated for the smallest value of the insulation resistance, the table below may be a guide for measurements made at 25°C winding temperature.

Limit values for nominal voltage < 2kV	
Measuring voltage	500 V, DC
Lowest insulation resistance of new, cleaned or repaired windings	10 MΩ
Critical value of specific insulation resistance after long operating periods	0.5 MΩ/kV

Commissioning

After installing a motor, the following checks and tests should be performed:

- Insulation and operating conditions are in compliance with name plate information,
- The motor is correctly placed and aligned,
- Shaft elements are properly installed,
- Insulation resistance is sufficient,
- The direction of rotation is correct,
- Cooling air flow is unobstructed,
- The rotor can rotate freely,
- All tightening elements and electrical connections are tight,
- Good ground connections are made,
- Bearings are properly lubricated,
- Additional parts are fitted, properly connected and maintainable,
- All protective measures are taken against touching the moving and electrical components,
- If there is a motor brake, it must be properly installed, connected and maintained,
- Start the motor up until it reaches its full idle speed,
- Pay attention to the noises and vibrations in the bearings and covers,
- If the motor does not run smoothly or if there are any unusual noises, turn the motor off. While the motor is slowing down, investigate the cause of the noise. If the fault disappears in deceleration, the cause is of electrical or magnetic type. Otherwise, the fault is mechanical.
- If the motor ran well at idle, it is loaded at nominal power. Observe the rotational smoothness and note the supply voltage and motor operating values.
- Note the temperature of the winding, bearings, and body until thermal equilibrium is reached.
- To stop the motor, open the breaker and wait for it to stop without braking and turn on the heater that prevents water condensation, if any.

When the motor is cold, temperature sensors must be connected and checked in such a way as to prevent an unexpected automatic start of the motor again, so that the thermal protection system does not cause damage or injury.

The checklist above cannot cover all possibilities. Therefore, other measures may be taken by the installation and commissioning an engineer who knows the specific conditions of the plant and the location, and the additional instructions related to them.

MAINTENANCE OF THE BEARINGS
Relubrication of the Motors with Lubrication Nipples

SHELL GADUS S2 V100 C3 type grease is used for the lubrication of the bearings during the production of the motors. Lubricated motors have a lubrication plate indicating the grease type, quantity and lubrication interval. The lubrication intervals given in the chart below are valid for normal continuous operating conditions i.e. nominal load and speed, vibration-free operation, coupling drive, 40°C coolant ambient temperature and high-grade bearing greases specified in the selection chart below.

K3K Greases	K3N Greases (higher temperature)
BP / ENERGREASE LS3	SHELL G3
MOBIUMOBILUX 3	SHELL RT3
ARAL / ARALU	ARAUARALUB 4340
B H L3 ELF / ROLEXA 3	ESSO / BEACON / 3

The lubrication intervals given below are for a bearing temperature of 70°C. These intervals are shortened if the temperature rises for a reason such as a belt drive. On the contrary, if the bearing temperature decreases, like at low ambient temperature, the lubrication intervals are extended. If the bearing temperature increases or decreases by approximately 15K, the lubrication interval is halved or doubled. However, regardless of the operating period, the grease should be changed after 3 years of operation at the latest due to aging. To relubricate, the motor is dismantled to the required extent, the bearings are thoroughly cleaned or replaced, then new grease is added. Fill the gaps of the bearings up to the side surfaces with grease. Do not grease put inside the bearing covers to prevent excessive lubrication of the bearings. Recommended greases include lithium soap as thickener and mineral oil as essential oil. Mineral oil contains additives to prevent oxidation and corrosion (Bearing greases K3N DIN 51 825). The amount of grease to put in a bearing should be approximately 1/3 of the internal space volume. By rough calculation, the amount of grease in grams to be used should be at least the inside diameter of the bearing in mm. Generally, different grease types should not be mixed with each other. Mixing greases with different types of thickeners may degrade its composition and physical properties. Even if thickeners are of the same type, possible differences in the additive can have detrimental effects. To ensure that the new grease is distributed evenly within the bearing, the bearings must be lubricated while the motor is running. Initially, the bearing temperature rises significantly and drops back to its normal value after excess grease is expelled from the bearing.

Relubricating Intervals in Lubricated Motors (Hours)						
No of Poles	Frame Size					
	132-160	180-200	225-250	280-315	355-400	450
2	5000	4000	3000	2500	2000	2000
4	10000	8000	6000	5000	4000	3000
≥6	15000	12000	9000	7000	5000	4000

The above table applies to Gamak motor-lubricated bearings to be used in clean environments, installation of the shaft in horizontal position, operating temperature of -20 / + 40 ° C and relative humidity of <80%. The lubrication interval should be halved for vertical running of the motor shaft. Lubrication period should also be halved if the environment is dusty.

Amount of Lubricant for Lubricated Motors (Grams)									
No of Poles	Frame Size								
	132	160	180	200	225-250	280	315-355	400	450
2						35	45	50	-
4	10	15	20	25	40	70	90	90	110
≥6									

Depending on the motor structure and operating cycles, the amount of lubrication for each type is specified on the list above.

Bearing Replacement

After slightly warming the inner ring, remove the ball bearings using a puller. Never use a hammer. The inner ring of cylindrical roller bearings must be heated quickly with the help of a flame and removed with a screw puller. If it still does not come off, grind out a V-shaped groove in the inner ring and break it. Before installing the bearings, check that the parts that need to be placed on the shaft are in place. Take great care during mounting and assembly and comply with the cleanliness rules. Heat the ball bearings and inner rings of the roller bearings in oil or air to a temperature of approximately 80°C, then slide them onto the shaft. Strong knocks should be avoided as they damage the bearings. Fill the bearings with the prescribed grease. When installing single-row angular contact ball bearings, make sure that the wide shoulder of the inner ring and the narrow shoulder of the outer ring face in the opposite direction to the axial thrust in the operating position. It should be checked that the sealing rings are placed correctly during installation.

Bearing Seals

New sealing rings should be impregnated with high viscosity hot oil (DIN 51 517 - C100) at 80°C before putting them on the bearing covers. Felt rings must be sized in such a way that they can slide into the shaft easily and grip well circumferentially. V-ring dust seals and radial shaft seals (oil seals) must be pushed into place with a suitable tool. Lubricant should be lightly applied to the contact surfaces of both gaskets. In order to prevent damage from excessive friction, one must be careful to place the V-ring dust seals in the correct axial position.

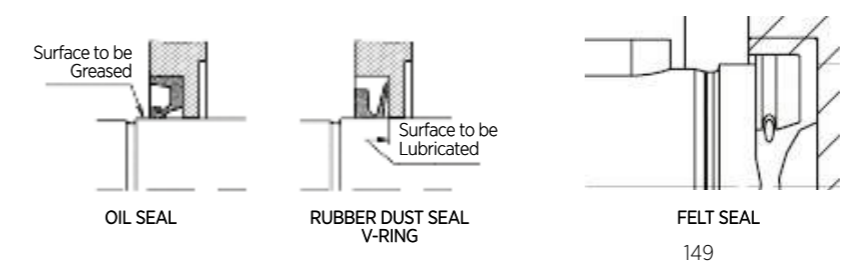

POSSIBLE MOTOR MALFUNCTIONS AND REMEDIES

General Information

MECHANICAL FAILURES							POSSIBLE CAUSES	SOLUTIONS
Bearing is excessive hot	Bearing is crowing	Bearing is knocking	Friction noise	Extremely high temperature	Radial vibration	Axial vibration		
							Excessive grease in the bed	Throw away excessive grease
							Bearing is dirty	Clean or replace the bearing Check the seals.
							Sealing collar is tightening the shaft	Better fit or replace the seal seat
							Belt is over-tensioned	Decrease the belt tension
							Coupling is twitching	Align the machine better
							Ambient temperature > 40°C	Use special high temperature grease
							Insufficient lubrication	Lubricate according to instructions
							Narrow bearing clearance	Use bed with larger clearance*
							Rust in bearing	Replace the bearing, check the seals
							Bearing is twitching	Check bearing for proper mounting, make the outer ring less tight
							Excessive bearing clearance	Use bearing with a narrower clearance*
							Foreign objects in bearing	Clean or replace the bearing
							Scars on the bearing or on the bearing ring	Replace the bearing, avoid vibrations when the motor is not running
							Rotating parts are rubbing	Realign them and eliminate the cause
							Insufficient cooling	Check the vents of the fan housing, the surface of the motor and, if necessary, the fan.
							Imbalance in the motor rotor	Balance the rotor again
							The rotor wobbling due to an inclined shaft	Consult the manufacturer
							Imbalance in transmission elements	Balance transmission elements
							Aligning is insufficient	Align the motor and the work machine sensitively in thermal balance.
							Incompatible transmission (Ex. Gear box)	Check and eliminate the cause
							The detection surface is not solid	Check and eliminate the cause
							Impacts from the heavy machine	Check and eliminate the cause

Defects in bearings are sometimes difficult to define. Change the bearing when in doubt.

* Consult the manufacturer.

POSSIBLE MOTOR MALFUNCTIONS AND REMEDIES

General Information

ELECTRICAL MALFUNCTIONS								POSSIBLE CAUSES	SOLUTIONS	
The motor does not start	Motor is not aligned well	Knocking noise at start-up	Knocking noise in operation	Knocked noise at twice the slip frequencies	Excessive high temperature when running without load	Over temperature when working with full load	Winding sections are overheating	Speed decreases when loaded	Opening the protection	
									Overload	Reduce load or choose a larger motor
									Excessive starting and/or overturning moment	Reduce the load torque or select a motor with higher torque characteristics.
									Mains voltage is low or the frequency is high	Correct the supply conditions
									Mains voltage is high or the frequency is high	Correct the supply conditions
									Correct the feeding conditions	Phase break
									Check the switch and the supply circuit.	Stator winding connected incorrectly
									Check the winding connection for inter winding or phase short circuit	Check the winding and insulation resistance. Consult the manufacturer.
									Insufficient connection in the cage	Consult the manufacturer.
									Excessive start-up temperature	Reduce the starting frequency or recalculate the motor identification.
									Excessive start-up time	Facilitate the start-up or recalculate the motor identification
									Defective contact in switch	Replace the defective contacts.
									Capacitor is defective	Check the capacitor voltage, replace it if necessary.



INDEX

A

Alignment - Operation and maintenance	146
Axial forces	19

B

Balance	28
Balancing - Operation and maintenance	147
Ball bearings - Standard motors	19
Bearing maintenance - Operation and maintenance	148
Bearing replacement - Operation and maintenance	149
Bearing seals - Operation and maintenance	149
Bearings - Standard motors	71
Cable entry	19
Canopy	18

C

Coding	12
Coil spring	20
Constant torque applications	
Cooling - Standard motors	19
Cylindrical roller bearings - Standard motor	19

D

Disc spring	71
Dual speed motors	54
Dust seal	67

E

Efficiency	145
Electronic start relay - Single phase motors	72

F

Flat belt pulleys	144
Frame forms	28
Frequency - Standard motors	77

G

Glands	19
Greases - Operation and maintenance	149

H

Heaters	18
High efficiency motors	40
Idling - Single phase motors	77

I

Installation - Operation and maintenance	146
Insulation Class	30
Insulation resistance - Operation and maintenance	145

L

Lubrication Nipples	21
---------------------	----

M

Mechanical construction - Single phase motors	18
Mechanical construction - Standard motors	18
Motors with permanent capacitor	78

N

Narrow V pulleys for belts	142
Noise - Standard motors	29
Noise pressure level	28

O

Operating in emergency - Smoke extraction motors	102
Orders of bedding	20
Orders of installation	20

P

Paint - Single phase motors	75
Paint - Standard motors	28
Parasites	144
Power - Standard motors	77
Power Coefficient	143
Product coding	12
Protection degrees	18
Pulleys for belts	142

R

Radial forces	21
---------------	----

S

Shaft end	28
Smoke extraction motors	102
Soft start	36
Standards	16
Start-up - Operation and maintenance	148
Start-up + Motors with permanent capacitor	70
Start-up frequency	34
Start-up time	35

T

Terminal box - Standard motors	70
Thermistors	36
Thermostats	36
Tolerances	36
Torque	28
Transmission couplings - Operation and maintenance	147
Transport - Operation and maintenance	146
Wire enamel	
Types of operation	34

V

Ventilation - Operation and maintenance	
Vibration	71
Voltage - Standard motors	

W

Water drain holes - Operation and maintenance	146
---	-----

