



■ شرکت جلیم (JLEM) در سال 1981 تأسیس شده و امروزه به یکی از شرکت‌های پیشرو در زمینه تولید سفارشی انواع موتور الکتریکی با تکیه بر تکنولوژی‌های روز دنیا است. این شرکت در منطقه دلتای رود یانگ تسه قرار گرفته و در حوزه توسعه و تولید سروو موتور، الکتروموتور، درایوهای کنترل دور و سایر تجهیزات الکترومکانیکی فعالیت می‌کند.

شرکت جلیم نایب رئیس انجمن صنفی موتورهای کوچک و متوسط کشور چین، عضو کمیته استاندارد ملی صنایع موتورهای دوار چینی و عضو گروه کاری استاندارد IEC است. مساحت این مجموعه بالغ بر 150.000 متر مربع است که حدود 100.000 متر مربع از آن به فضای ساختمان‌های کاری این شرکت اختصاص یافته است. شرکت جلیم نزدیک به 1000 کارمند داشته و دارایی‌های آن بیش از یک میلیارد یوان چین است.

از جمله مهم‌ترین خطوط تولید این شرکت عبارتند از:

- خط تولید انواع سروو موتور و درایو کنترل دور موتورهای مغناطیس دائم
 - خط تولید موتور و درایوهای کنترل وسایل نقلیه الکتریکی
 - خط تولید موتورهای القایی سه فاز با بازدهی بالا و درایوهای مخصوص آن‌ها
- محصولات این شرکت طیف وسیعی از صنایع را پوشش می‌دهند، از جمله:
- خودروهای الکتریکی
 - ربات‌های صنعتی
 - ماشین‌آلات CNC
 - اتوماسیون‌ها و خط تولیدهای هوشمند
 - صنایع معدن، زغال سنگ، نفت و ...
 - ماشین‌آلات صنعتی مانند پمپ، کمپرسور و ...



شرکت جلیم بیش از 3000 نوع موتور را با مشخصات فنی مختلف در بازه توانی 0.1 تا 1500 کیلووات و مطابق با استاندارد IEC تولید می‌نماید.

این شرکت موفق به اخذ گواهینامه‌های معتبر بین‌المللی از جمله ISO9001 (کیفیت)، ISO14001 (مدیریت زیست محیطی و تولید پاک)، 16949 (سیستم کیفیت)، گواهینامه سیستم مدیریت ایمنی و بهداشت حرفه ای GB/T28001، تأییدیه CCC و CQC چین و گواهینامه صرفه جویی در مصرف انرژی چین (CECP) شده است. جلیم مجوز تولید موتور ضد انفجار، تأییدیه ATEX و IECEx برای موتورهای ضد انفجار و تأییدیه GL، CCS و BV برای موتورهای دریایی را نیز داراست.

■ استاندارد IEC توسط کمیسیون بین المللی الکتروتکنیک تدوین شده و به منظور طبقه بندی راندمان موتورهای الکتریکی به کار می رود. طبق این استاندارد، راندمان الکتروموتورها در چهار سطح زیر قرار می گیرد:

IE1: بازده استاندارد / IE2: بازده بالا / IE3: بازده ممتاز / IE4: بازده فوق ممتاز

الکتروموتورهایی که از شرکت LEM در ایران موجود می شوند فقط دارای استاندارد IE1 هستند و سایر استانداردها در ایران موجود نمی باشد در جدول زیر میزان راندمان توان های مختلف الکتروموتورهای IE1 درج شده است

Power - توان		Speed (r.p.m) - سرعت الکتروموتور			
Kw	Hp	3000 - 2 Pole	1500 - 4 Pole	1000 - 6 Pole	750 - 8 Pole
0.12	0/18	45.0	50.0	38.3	31.0
0.18	0/25	52.8	57.0	45.5	38.0
0.25	0/33	58.2	61.5	52.1	43.4
0.37	0/5	63.9	66.0	59.7	49.7
0.55	0/75	69.0	70.0	65.8	56.1
0.75	1	72.1	72.1	70.0	61.2
1.1	1/5	75.0	75.0	72.9	66.5
1.5	2	77.2	77.2	75.2	70.2
2.2	3	79.7	79.7	77.7	74.2
3	4	81.5	81.5	79.7	77.0
4	5/5	83.1	83.1	81.4	79.2
5.5	7/5	84.7	84.7	83.1	81.4
7.5	10	86.0	86.0	84.7	83.1
11	15	87.6	87.6	86.4	85.0
15	20	88.7	88.7	87.7	86.2
18.5	25	89.3	89.3	88.6	86.9
22	30	89.9	89.9	89.2	87.4
30	40	90.7	90.7	90.2	88.3
37	50	91.2	91.2	90.8	88.8
45	60	91.7	91.7	91.4	89.2
55	75	92.1	92.1	91.9	89.7
75	100	92.7	92.7	92.6	90.3
90	125	93.0	93.0	92.9	90.7
110	150	93.3	93.3	93.3	91.1
132	180	93.5	93.5	93.5	91.5
160	220	93.8	93.8	93.8	91.9
200	275	94.0	94.0	94.0	92.5
250	340	94.0	94.0	94.0	92.5
315	430	94.0	94.0	94.0	92.5
355	480	94.0	94.0	94.0	92.5
400	540	94.0	94.0	94.0	92.5
450	610	94.0	94.0	94.0	92.5
500-1000	680	94.0	94.0	94.0	92.5

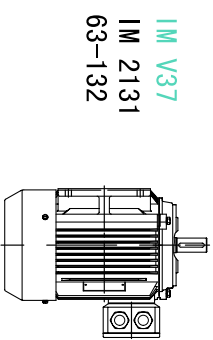
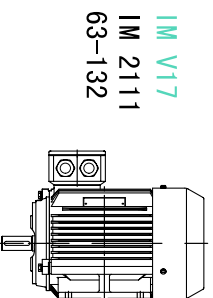
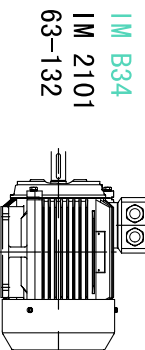
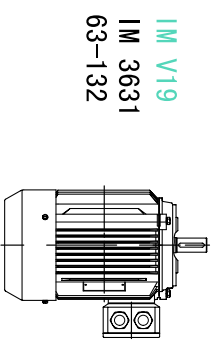
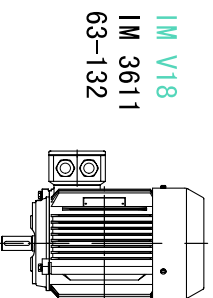
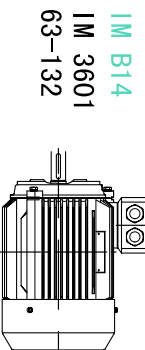
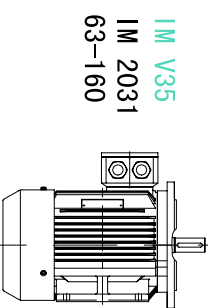
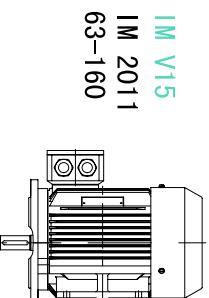
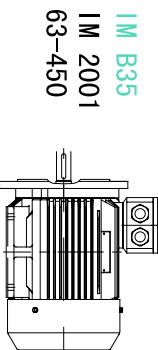
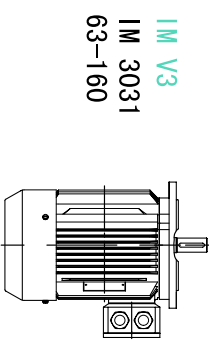
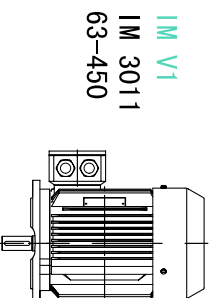
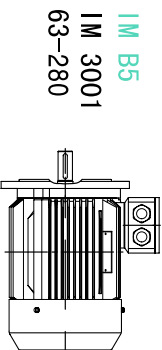
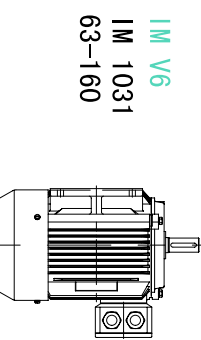
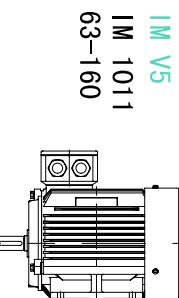
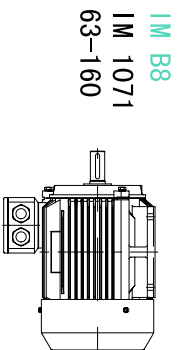
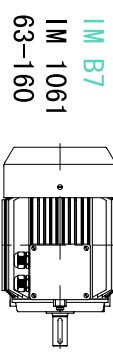
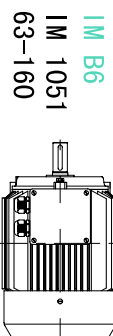
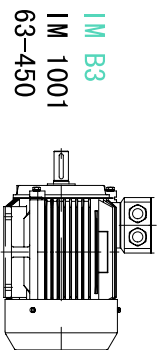

نقشه انفجاری

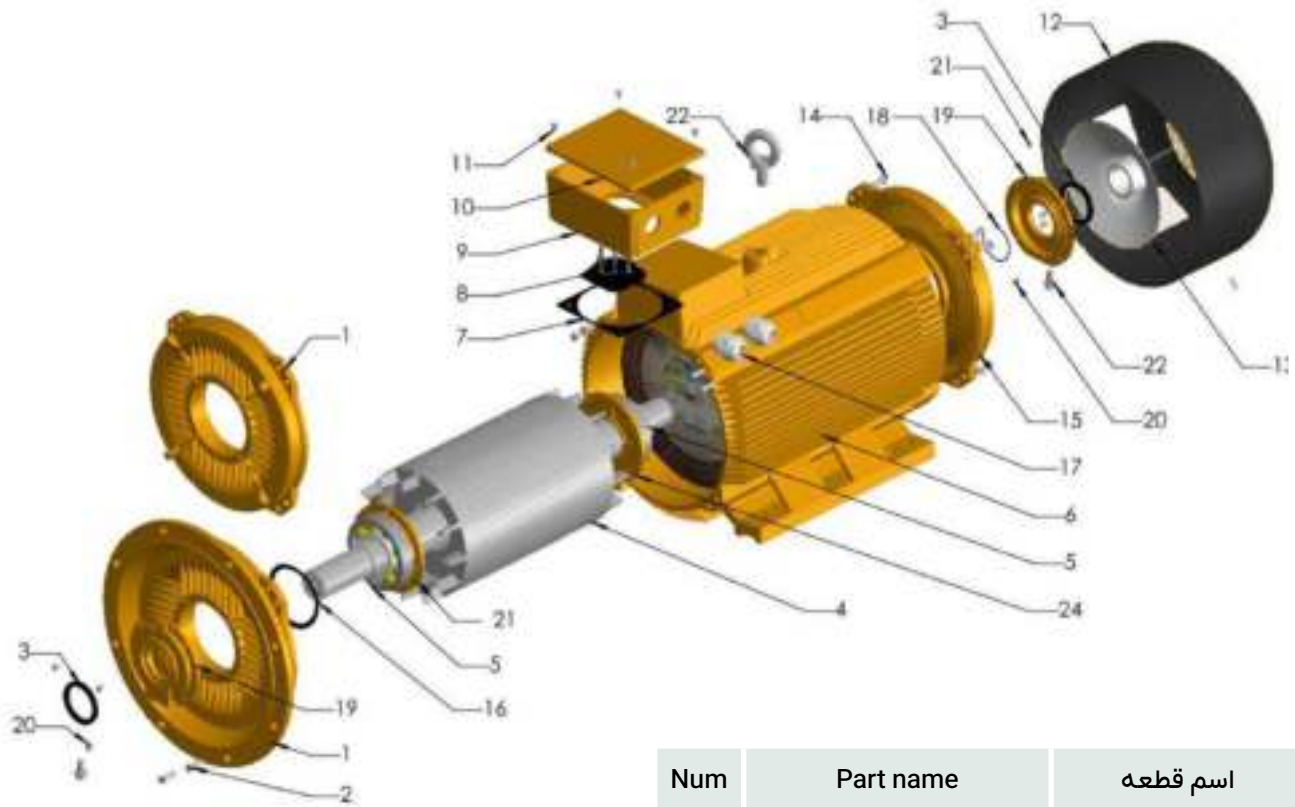

Num	Part name	اسم قطعه
1	Flange / End shield DE	فلنج یا براکت جلویی موتور
2	Flange / End shield bolt DE	پیچ فلنج یا براکت جلویی موتور
3	Oil seal	کاسه نمد
4	Rotor	روتور
5	Bearing DE / NDE	بیرینگ ها
6	Motor housing with stator	پوسته موتور به همراه استاتور
7	Terminal box base seal	واشر جعبه ترمینال موتور
8	Terminal board	برد ترمینال
9	Terminal box	جعبه ترمینال
10	Terminal box cap	درپوش جعبه ترمینال

Num	Part name	اسم قطعه
11	Terminal box cap screw	پیچ های درپوش جعبه ترمینال
12	Fan cover	درپوش فن
13	Fan	فن
14	Flange / End shield bolt NDE	پیچ براکت انتهایی موتور
15	End shield NDE	براکت انتهایی موتور
16	Wave washer	واشر موجی
17	Cable gland	گلند کابل
18	Circlip	خار فنری
19	Bearing cap outer DE, NDE	درپوش بیرونی بیرینگ ها
20	Bearing cap screw	پیچ درپوش بیرینگ
21	Bearing cap inner DE, NDE	درپوش داخلی بیرینگ ها
22	Eye - bolt	پیچ چشمی

JM - 225M - 4

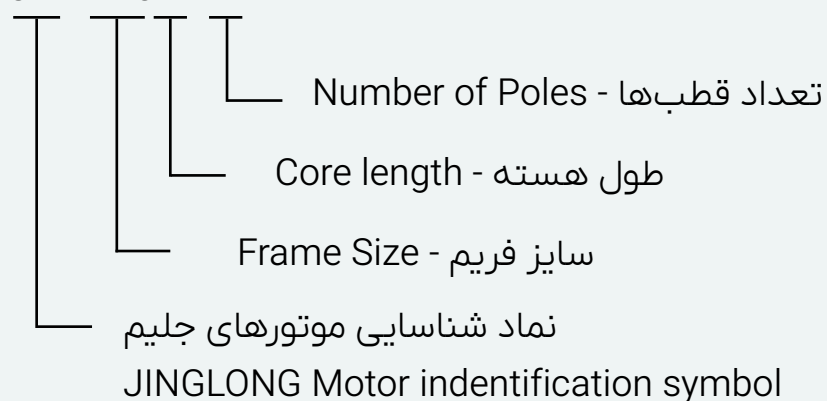

میزان صدا

Output (Kw)	3000 - 2 Pole		1500 - 4 Pole		1000 - 6 Pole	
	فشار صدا dB(A)	قدرت صدا dB(A)	فشار صدا dB(A)	قدرت صدا dB(A)	فشار صدا dB(A)	قدرت صدا dB(A)
0.75	56	67	47	58	45	57
1.1	56	67	49	61	45	57
1.5	61	73	49	61	49	61
2.2	62	74	52	64	53	65
3	64	76	52	64	57	69
4	65	77	53	65	57	69
5.5	68	80	59	71	57	69
7.5	68	80	59	71	61	73
11	73	86	62	72	61	73
15	73	86	63	73	61	73
18.5	73	86	64	76	64	76
22	75	88	64	76	64	76
30	78	92	66	79	64	76
37	78	92	68	81	66	78
45	78	92	68	81	68	80
55	79	93	70	83	68	80
75	80	94	72	85	73	85
90	80	94	73	86	73	85
110	82	96	80	93	73	85
132	82	96	80	93	73	85
160	85	99	84	97	80	92
200	86	100	84	97	80	92
250	88	102	88	101	80	92
315	89	103	88	101		

مقادیر اندازه گیری شده در فرکانس کاری ۵۰HZ می باشد

3000 r.p.m

Type	Output Power		Rated Speed r.p.m	Efficiency	Efficiency at 75% load	Efficiency at 50% load	Power factor $\cos \phi$	Rated current			Rated T Torque N.m	T_s/T_n	T_{max}/T_n	I_s/I_n	Weight kg
	Kw	Hp						380 V	400 V	415 V					
JM - 711-2	0.37	0.5	2740	63.9	63.9	62.6	0.81	1.09	1.03	0.99	1.29	2.3	2.2	6.1	9.6
JM - 712-2	0.55	0.75	2740	69.0	69.0	67.6	0.82	1.48	1.40	1.35	1.92	2.3	2.3	6.1	10.2
JM - 801-2	0.75	1	2840	72.1	72.1	70.7	0.83	1.90	1.81	1.74	2.52	2.2	2.3	6.1	13.1
JM - 802-2	1.1	1.5	2840	75.0	75.0	73.5	0.84	2.65	2.52	2.43	3.70	2.2	2.3	6.9	14.3
JM - 90S - 2	1.5	2	2840	77.2	77.2	75.7	0.84	3.51	3.34	3.22	5.04	2.2	2.3	7.0	18.5
JM - 90L - 2	2.2	3	2840	79.7	79.7	78.1	0.85	4.93	4.69	4.52	7.40	2.2	2.3	7.0	21.8
JM - 100L - 2	3	4	2860	81.5	81.5	79.9	0.87	6.43	6.11	5.89	10.02	2.2	2.3	7.5	29.5
JM - 112M - 2	4	5.5	2880	83.1	83.1	81.4	0.88	8.31	7.90	7.61	13.3	2.2	2.3	7.5	35.6
JM - 132S1-2	5.5	7.5	2900	84.7	84.7	83.0	0.86	11.5	10.9	10.5	18.1	2.2	2.3	7.5	56.5
JM - 132S2-2	7.5	10	2900	86.0	86.0	84.3	0.88	15.1	14.3	13.8	24.7	2.2	2.3	7.5	70
JM - 160M1-2	11	15	2930	87.6	87.6	85.8	0.89	21.4	20.4	19.6	35.9	2.2	2.3	7.5	100
JM - 160M2-2	15	20	2930	88.7	88.7	86.9	0.89	28.9	27.4	26.4	48.9	2.2	2.3	7.5	110
JM - 160L - 2	18.5	25	2930	89.3	89.3	87.5	0.90	35.0	33.2	32.0	60.3	2.2	2.3	7.5	128
JM - 180M - 2	22	30	2940	89.9	89.9	88.1	0.90	41.3	39.2	37.8	71.5	2.0	2.3	7.5	165
JM - 200L1-2	30	40	2950	90.7	90.7	88.9	0.90	55.8	53	51.1	97.1	2.0	2.3	7.5	204
JM - 200L2-2	37	50	2950	91.2	91.2	89.4	0.90	68.5	65.1	62.7	119.8	2.0	2.3	7.5	228
JM - 225M - 2	45	60	2960	91.7	91.7	89.9	0.90	82.8	78.7	75.9	145.2	2.0	2.3	7.5	282
JM - 250M - 2	55	75	2965	92.1	92.1	90.3	0.90	101	95.8	92.3	177.2	2.0	2.3	7.5	361
JM - 280S - 2	75	100	2970	92.7	92.7	90.8	0.90	137	130	125	241.2	2.0	2.3	7.0	483
JM - 280M - 2	90	125	2970	93.0	93.0	91.1	0.91	162	153	148	289.4	2.0	2.3	7.1	493
JM - 315S - 2	110	150	2975	93.3	93.3	91.4	0.91	197	187	180	353.1	1.8	2.2	7.1	834
JM - 315M - 2	132	180	2975	93.5	93.5	91.6	0.91	236	224	216	423.7	1.8	2.2	7.1	909
JM - 315L1-2	160	200	2975	93.8	93.8	91.9	0.92	282	268	258	513.6	1.8	2.2	7.1	957
JM - 315L2-2	200	270	2975	94.0	94.0	92.1	0.92	351	334	322	642.0	1.8	2.2	7.1	1084
JM - 355M - 2	250	340	2980	94.0	94.0	92.1	0.92	439	417	402	801.2	1.6	2.2	7.1	1850
JM - 355L - 2	315	430	2980	94.0	94.0	92.1	0.92	553	526	507	1009.5	1.6	2.2	7.1	2200

 **1500 r.p.m**

Type	Output Power		Rated Speed r.p.m	Efficiency	Efficiency at 75% load	Efficiency at 50% load	Power factor $\cos \varphi$	Rated current			Rated T Torque N.m	T_s / T_n	T_{max} / T_n	I_s / I_n	Weight kg
	Kw	Hp						380 V	400 V	415 V					
JM - 711-4	0.25	0.37	1330	61.5	61.5	60.3	0.74	0.83	0.79	0.76	1.80	2.1	2.2	5.2	11.2
JM - 712-4	0.37	0.5	1330	66.0	66.0	64.7	0.75	1.14	1.08	1.04	2.66	2.1	2.2	5.2	11.8
JM - 801-4	0.55	0.75	1390	70.0	70.0	68.6	0.75	1.59	1.51	1.46	3.78	2.4	2.3	5.2	13.8
JM - 802-4	0.75	1	1390	72.1	72.1	70.7	0.76	2.08	1.98	1.90	5.15	2.3	2.3	6.0	14.5
JM - 90S - 4	1.1	1.5	1390	75.0	75.0	73.5	0.77	2.89	2.75	2.65	7.56	2.3	2.3	6.0	17.3
JM - 90L - 4	1.5	2	1390	77.2	77.2	75.7	0.77	3.83	3.64	3.51	10.3	2.3	2.3	6.0	23
JM - 100L1-4	2.2	3	1390	79.7	79.7	78.1	0.81	5.18	4.92	4.74	15.1	2.3	2.3	7.0	30.3
JM - 100L2-4	3	4	1410	81.5	81.5	79.9	0.82	6.82	6.48	6.25	20.3	2.3	2.3	7.0	31.5
JM - 112M - 4	4	5.5	1410	83.1	83.1	81.4	0.82	8.92	8.47	8.17	27.1	2.3	2.3	7.0	38
JM - 132S - 4	5.5	7.5	1435	84.7	84.7	83.0	0.83	11.9	11.3	10.9	36.6	2.3	2.3	7.0	61.5
JM - 132M - 4	7.5	10	1440	86.0	86.0	84.3	0.84	15.8	15.0	14.4	49.7	2.3	2.3	7.0	70.5
JM - 160M - 4	11	15	1440	87.6	87.6	85.8	0.84	22.7	21.6	20.8	73.0	2.2	2.3	7.0	104
JM - 160L - 4	15	20	1460	88.7	88.7	86.9	0.85	30.2	28.7	27.7	98.1	2.2	2.3	7.5	124
JM - 180M - 4	18.5	25	1460	89.3	89.3	87.5	0.86	36.6	34.8	33.5	121.0	2.2	2.3	7.5	160
JM - 180L - 4	22	30	1470	89.9	89.9	88.1	0.86	43.2	41.1	39.6	142.9	2.2	2.3	7.5	171
JM - 200L - 4	30	40	1470	90.7	90.7	88.9	0.86	58.4	55.5	53.5	194.9	2.2	2.3	7.2	230
JM - 225S - 4	37	50	1470	91.2	91.2	89.4	0.87	70.9	67.3	64.9	240.4	2.2	2.3	7.2	268
JM - 225M - 4	45	60	1475	91.7	91.7	89.9	0.87	85.7	81.4	78.5	291.4	2.2	2.3	7.2	301
JM - 250M - 4	55	75	1475	92.1	92.1	90.3	0.87	104	99.1	95.5	356.1	2.2	2.3	7.2	363
JM - 280S - 4	75	100	1480	92.7	92.7	90.8	0.87	141	134	129	484.0	2.2	2.3	6.8	491
JM - 280M - 4	90	125	1480	93.0	93.0	91.1	0.87	169	161	155	580.7	2.2	2.3	6.8	576
JM - 315S - 4	110	150	1480	93.3	93.3	91.4	0.88	204	193	186	709.8	2.1	2.2	6.9	805
JM - 315M - 4	132	180	1480	93.5	93.5	91.6	0.88	244	232	223	851.8	2.1	2.2	6.9	913
JM - 315L1-4	160	200	1480	93.8	93.8	91.9	0.89	291	277	267	1032.4	2.1	2.2	6.9	1023
JM - 315L2-4	200	270	1480	94.0	94.0	92.1	0.89	363	345	333	1290.5	2.1	2.2	6.9	1169
JM - 355M - 4	250	340	1490	94.0	94.0	92.1	0.90	449	427	411	1602.3	2.1	2.2	6.9	1660
JM - 355L - 4	315	430	1490	94.0	94.0	92.1	0.90	566	537	518	2019.0	2.1	2.2	6.9	1850

▶ 1000 r.p.m

Type	Output Power		Rated Speed r.p.m	Efficiency	Efficiency at 75% load	Efficiency at 50% load	Power factor $\cos \phi$	Rated current			Rated T Torque N.m	T_s/T_n	T_{max}/T_n	I_s/I_n	Weight kg
	Kw	Hp						380 V	400 V	415 V					
JM - 711-6	0.18	0.25	850	45.5	45.5	44.6	0.66	0.91	0.87	0.83	2.02	1.9	2.0	4.0	9
JM - 712-6	0.25	0.37	850	52.1	52.1	51.1	0.68	1.07	1.02	0.98	2.81	1.9	2.0	4.0	9.5
JM - 801-6	0.37	0.5	885	59.7	59.7	58.5	0.70	1.35	1.28	1.23	3.99	1.9	2.0	4.7	12.3
JM - 802-6	0.55	0.75	885	65.8	65.8	64.5	0.72	1.76	1.68	1.62	5.94	1.9	2.1	4.7	13.5
JM - 90S - 6	0.75	1	910	70.0	70.0	68.6	0.72	2.26	2.15	2.07	7.87	2.0	2.1	5.3	17.5
JM - 90L - 6	1.1	1.5	910	72.9	72.9	71.4	0.72	3.18	3.02	2.92	11.5	2.0	2.1	5.5	20 20
JM - 100L - 6	1.5	12	920	75.2	75.2	73.7	0.75	4.04	3.84	3.70	15.6	2.0	2.1	5.5	29
JM - 112M - 6	2.2	3	935	77.7	77.7	76.1	0.76	5.66	5.38	5.18	22.5	2.0	2.1	6.5	38
JM - 132S - 6	3	4	960	79.7	79.7	78.1	0.76	7.52	7.15	6.89	29.8	2.1	2.1	6.5	59
JM - 132M1-6	4	5.5	960	81.4	81.4	79.8	0.76	9.82	9.33	9.00	39.8	2.1	2.1	6.5	68
JM - 132M2-6	5.5	7.5	960	83.1	83.1	81.4	0.77	13.1	12.4	12.0	54.7	2.1	2.1	6.5	77
JM - 160M - 6	7.5	10	970	84.7	84.7	83.0	0.78	17.2	16.4	15.8	73.8	2.0	2.1	6.5	100
JM - 160L - 6	11	15	970	86.4	86.4	84.7	0.78	24.8	23.6	22.7	108.3	2.0	2.1	6.5	121
JM - 180L - 6	15	20	970	87.7	87.7	85.9	0.81	32.1	30.5	29.4	147.7	2.0	2.1	7.0	163
JM - 200L1-6	18.5	25	980	88.6	88.6	86.8	0.81	39.2	37.2	35.9	180.3	2.1	2.1	7.0	207
JM - 200L2-6	22	30	980	89.2	89.2	87.4	0.83	45.1	42.9	41.3	214.4	2.0	2.1	7.0	223
JM - 225M - 6	30	40	980	90.2	90.2	88.4	0.84	60.2	57.1	55.1	292.3	2.0	2.1	7.0	274
JM - 250M - 6	37	50	980	90.8	90.8	89.0	0.86	72.0	68.4	65.9	360.6	2.1	2.1	7.0	350
JM - 280S - 6	45	60	980	91.4	91.4	89.6	0.86	87.0	82.6	79.6	438.5	2.1	2.0	7.0	452
JM - 280M - 6	55	75	980	91.9	91.9	90.1	0.86	106	100	96.8	536.0	2.1	2.0	7.0	507
JM - 315S - 6	75	100	985	92.6	92.6	90.7	0.86	143	136	131	727.2	2.0	2.0	6.7	796
JM - 315M - 6	90	125	985	92.9	92.9	91.0	0.86	171	163	157	872.6	2.0	2.0	6.7	889
JM - 315L1-6	110	150	985	93.3	93.3	91.4	0.86	208	198	191	1066.5	2.0	2.0	6.7	929
JM - 315L2-6	132	180	985	93.5	93.5	91.6	0.87	247	234	226	1279.8	2.0	2.0	6.7	1062
JM - 355M1-6	160	200	985	93.8	93.8	91.9	0.88	295	280	270	1551.3	1.9	2.0	6.7	1500
JM - 355M2-6	200	270	985	94.0	94.0	92.1	0.88	367	349	336	1939.1	1.9	2.0	6.7	1650
JM - 355L - 6	250	340	985	94.0	94.0	92.1	0.88	459	436	420	2423.9	1.9	2.0	6.7	1880

750 r.p.m

Type	Output Power		Rated Speed r.p.m	Efficiency	Efficiency at 75% load	Efficiency at 50% load	Power factor $\cos \phi$	Rated current			Rated T Torque N.m	T_s / T_n	T_{max} / T_n	I_s / I_n	Weight kg
	Kw	Hp						380 V	400 V	415 V					
JM - 711-8	0.09	0.12	600	40.0	40.0	39.2	0.57	0.60	0.57	0.55	1.43	1.8	1.9	2.8	8.8
JM - 712-8	0.12	0.18	600	31.0	31.0	30.4	0.57	1.03	0.98	0.94	1.91	1.8	1.9	2.8	9.2
JM - 801-8	0.18	0.25	645	38.0	38.0	37.2	0.61	1.18	1.12	1.08	2.67	1.8	1.9	3.3	11.2
JM - 802-8	0.25	0.37	645	43.4	43.4	42.5	0.61	1.43	1.36	1.31	3.70	1.8	1.9	3.3	13
JM - 90S - 8	0.37	0.5	670	49.7	49.7	48.7	0.61	1.85	1.76	1.70	5.27	1.8	1.9	4.0	18.5
JM - 90L - 8	0.55	0.75	670	56.1	56.1	55.0	0.61	2.44	2.32	2.24	7.84	1.8	2.0	4.0	19.7
JM - 100L1-8	0.75	1	680	61.2	61.2	60.0	0.67	2.78	2.64	2.54	10.5	1.8	2.0	4.0	28.5
JM - 100L2-8	1.1	1.5	680	66.5	66.5	65.2	0.69	3.64	3.46	3.34	15.4	1.8	2.0	5.0	30
JM - 112M - 8	1.5	2	690	70.2	70.2	68.8	0.70	4.64	4.41	4.25	20.8	1.8	2.0	5.0	38
JM - 132S - 8	2.2	3	705	74.2	74.2	72.7	0.71	6.34	6.03	5.81	29.8	1.8	2.0	6.0	61.5
JM - 132M - 8	3	4	705	77.0	77.0	75.5	0.73	8.11	7.70	7.43	40.6	1.8	2.0	6.0	75
JM - 160M1-8	4	5.5	720	79.2	79.2	77.6	0.73	10.5	9.99	9.63	53.1	1.9	2.0	6.0	91
JM - 160M2-8	5.5	7.5	720	81.4	81.4	79.8	0.74	13.9	13.2	12.7	73.0	1.9	2.0	6.0	103
JM - 160L - 8	7.5	10	720	83.1	83.1	81.4	0.75	18.3	17.4	16.7	99.5	1.9	2.0	6.0	124
JM - 180L - 8	11	15	730	85.0	85.0	83.3	0.76	25.9	24.6	23.7	143.9	2.0	2.0	6.5	165
JM - 200L - 8	15	20	730	86.2	86.2	84.5	0.76	34.8	33.0	31.9	196.2	2.0	2.0	6.6	225
JM - 225S - 8	18.5	25	730	86.9	86.9	85.2	0.76	42.6	40.4	39.0	242.0	1.9	2.0	6.6	256
JM - 225M - 8	22	30	730	87.4	87.4	85.7	0.78	49.0	46.6	44.9	287.8	1.9	2.0	6.6	275
JM - 250M - 8	30	40	735	88.3	88.3	86.5	0.79	65.3	62.1	59.8	389.8	1.9	2.0	6.5	350
JM - 280S - 8	37	50	735	88.8	88.8	87.0	0.79	80.1	76.1	73.4	480.7	1.9	2.0	6.6	472
JM - 280M - 8	45	60	735	89.2	89.2	87.4	0.79	97.0	92.2	88.8	584.7	1.9	2.0	6.6	520
JM - 315S - 8	55	75	735	89.7	89.7	87.9	0.81	115	109	105	714.6	1.8	2.0	6.6	815
JM - 315M - 8	75	100	735	90.3	90.3	88.5	0.81	156	148	143	974.5	1.8	2.0	6.2	906
JM - 315L1-8	90	125	735	90.7	90.7	88.9	0.82	184	175	168	1169.4	1.8	2.0	6.4	987
JM - 315L2-8	110	150	735	91.1	91.1	89.3	0.82	224	213	205	1429.3	1.8	2.0	6.4	995
JM - 355M1-8	132	180	740	91.5	91.5	89.7	0.82	267	254	245	1703.5	1.8	2.0	6.4	1700
JM - 355M2-8	160	200	740	91.9	91.9	90.1	0.82	323	306	295	2064.9	1.8	2.0	6.4	1850
JM - 355L - 8	200	270	740	92.5	92.5	90.7	0.83	396	376	362	2581.1	1.8	2.0	6.4	1930

مشخصات ابعادی

IMB3 H63-355

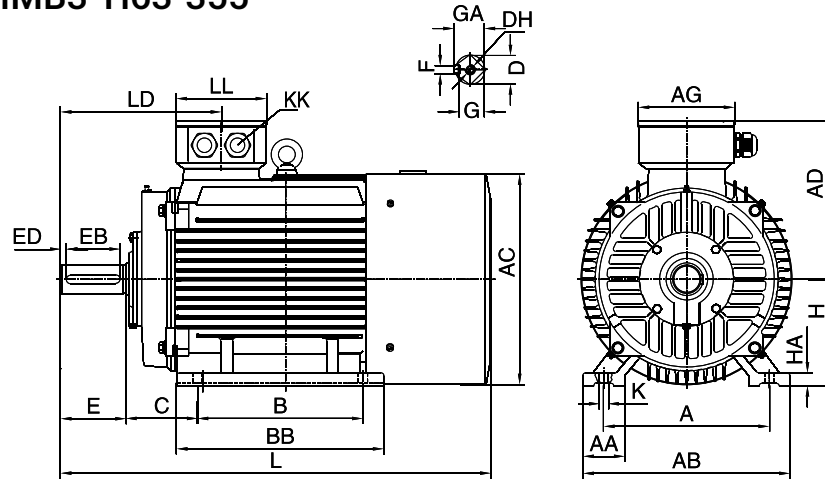

160-355

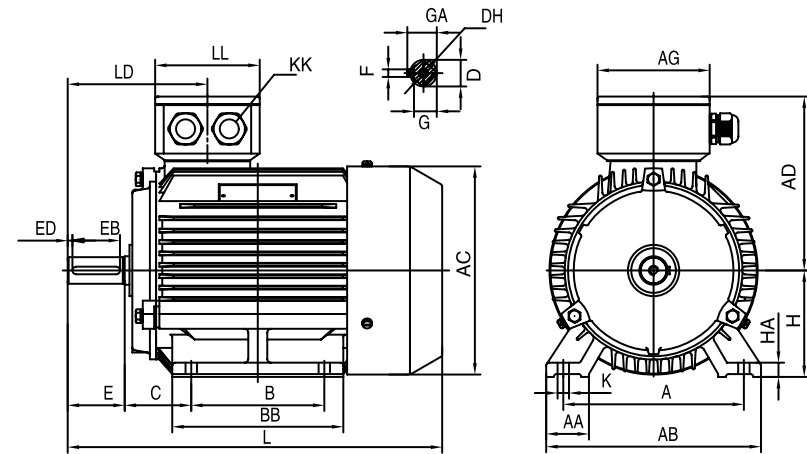

71-132

Type	Pole	A	AA	AB	AC	AD	AG	B	BB	C	D	DH	E	EB	ED	F	G	GA	H	HA	K	KK	L	LD	LL
71	2,4,6	112	32	144	136	119	94	90	120	45	14	M5X12	30	25	2.5	5	11	16	71	8	4-φ7	1-20X1.5	242	99	94
80	2,4,6,8	125	34	160	155.4	131	94	100	130	50	19	M6X16	40	30	5	6	15.5	21.5	80	10	4-φ10	1-M25X1.5	284	112	94
90S	2,4,6,8	140	36	176	175.4	148	102	100	130	56	24	M8X19	50	40	5	8	20	27	90	12	4-φ10	1-M25X1.5	318	130	102
90L	2,4,6,8	140	36	176	175.4	148	102	125	155	56	24	M8X19	50	40	5	8	20	27	90	12	4-φ10	1-M25X1.5	343	130	102
100L	2,4,6,8	160	40	200	195.4	162	102	140	176	63	28	M10X22	60	50	5	8	24	31	100	14	4-φ12	1-M32X1.5	370	139	102
112M	2,4,6,8	190	45	226	219.4	183	118	140	180	70	28	M10X22	60	50	5	8	24	31	112	15	4-φ12	2-M32X1.5	394	147	110
132S	2,4,6,8	216	55	262	258.4	203	118	140	186	89	38	M12X28	80	65	7.5	10	33	41	132	18	4-φ12	2-M32X1.5	456	172	110
132M	4,6,8	216	55	262	258.4	203	118	178	224	89	38	M12X28	80	65	7.5	10	33	41	132	18	4-φ12	2-M32X1.5	494	172	110
160M	2,4,6,8	254	65	314	314	251	162	210	260	108	42	M16X36	110	90	10	12	87	45	160	20	4-φ14.5	2-M40X1.5	608	256	152
160L	2,4,6,8	254	65	314	314	251	162	254	304	108	42	M16X36	110	90	10	12	37	45	160	20	4-φ14.5	2-M40X1.5	652	256	152
180M	2,4,8	279	70	349	355	267	162	241	311	121	48	M16X36	110	90	10	14	42.5	51.5	180	22	4-φ14.5	2-M40X1.5	688	271	152
180L	4,6,8	279	70	349	355	267	162	279	349	121	48	M16X36	110	90	10	14	42.5	51.5	180	22	4-φ14.5	2-M40X1.5	726	271	152
200L	2,4,6,8	318	70	388	397	299	210	305	369	133	55	M20X42	110	100	5	16	49	59	200	25	4-φ18.5	2-M50X1.5	771	296	190
225S	4,8	356	75	431	446	322	210	286	368	149	60	M20X42	140	125	7.5	18	53	64	225	28	4-φ18.5	2-M50X1.5	824	329	190
225M	2	356	75	431	446	322	210	311	393	149	55	M20X42	110	100	5	16	49	59	225	28	4-φ18.5	2-M50X1.5	819	299	190

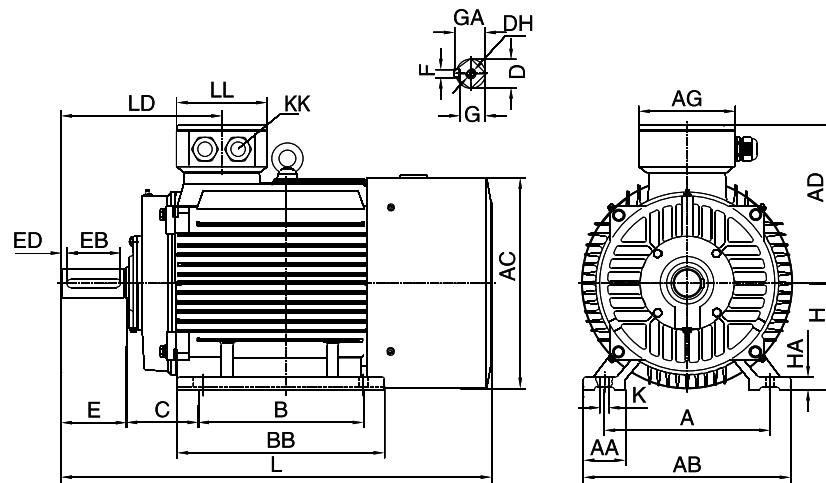

160-355

Type	Pole	A	AA	AB	AC	AD	AG	B	BB	C	D	DH	E	EB	ED	F	G	GA	H	HA	K	KK	L	LD	LL
225M	4,6,8	356	75	431	446	322	210	311	393	149	60	M20X42	140	125	7.5	18	53	64	225	28	4-φ18.5	2-M50X1.5	849	329	190
250M	2	406	80	484	485	358	248	349	445	168	60	M20X42	140	125	7.5	18	53	64	250	30	4-φ24	2-M63X1.5	910	347	218
250M	4,6,8	406	80	484	485	358	248	349	445	168	65	M20X42	140	125	7.5	18	58	69	250	30	4-φ24	2-M63X1.5	910	347	218
280S	2	457	85	542	547	387	248	368	485	190	65	M20X42	140	125	7.5	18	58	69	280	35	4-φ24	2-M63X1.5	982	355.5	218
280S	4,6,8	457	85	542	547	367	248	368	485	190	75	M20X42	140	125	7.5	20	67.5	79.5	280	35	4-φ24	2-M63X1.5	982	355.5	218
280M	2	457	85	542	547	387	248	419	536	190	65	M20X42	140	125	7.5	18	58	69	280	35	4-φ24	2-M63X1.5	1033	355.5	218
280M	4,6,8	457	85	542	547	387	248	419	536	190	75	M20X42	140	125	7.5	20	67.5	79.5	280	35	4-φ24	2-M63X1.5	1033	355.5	218
315S	2	508	120	628	620	527	320	406	570	216	65	M20X42	140	125	7.5	18	58	69	315	45	4-φ28	2-M63X1.5	1178	397	280
315S	4,6,8,10	508	120	628	620	527	320	406	570	216	80	M20X42	170	160	5	22	71	85	315	45	4-φ28	2-M63X1.5	1208	427	280
315M	2	508	120	628	620	527	320	457	680	216	65	M20X42	140	125	7.5	18	58	69	315	45	4-φ28	2-M63X1.5	1288	397	280
315M	4,6,8,10	508	120	628	620	527	320	457	680	216	80	M20X42	170	160	5	22	71	85	315	45	4-φ28	2 M63X1.5	1318	427	280
315L	2	508	120	628	620	527	320	508	680	216	65	M20X42	140	125	7.5	18	58	69	315	45	4-φ28	2-M63X1.5	1288	397	280
315L	4,6,8,10	508	120	628	620	527	320	508	680	216	80	M20X42	170	160	5	22	71	85	315	45	4-φ28	2-M63X1.5	1318	427	280
355M	2	610	116	726	698	642	380	560	750	254	75	M20X42	140	130	5	20	67.5	79.5	355	52	6-φ28	2-M63X1.5	1486	414	330
355M	4,6,8,10	610	116	726	698	642	380	560	750	254	85	M24X50	170	169	5	25	86	100	355	52	6-φ28	2-M63X1.5	1516	444	330
355L	2	610	116	726	698	642	380	630	750	254	75	M20X42	140	130	5	20	67.5	79.5	355	52	6-φ28	2-M63X1.5	1486	414	330
355L	4,6,8,10	610	116	726	698	642	380	630	750	254	35	H24X50	170	160	5	25	86	100	355	52	6-φ28	2-M63X1.5	1516	444	330

► **IMB5 H63-355**

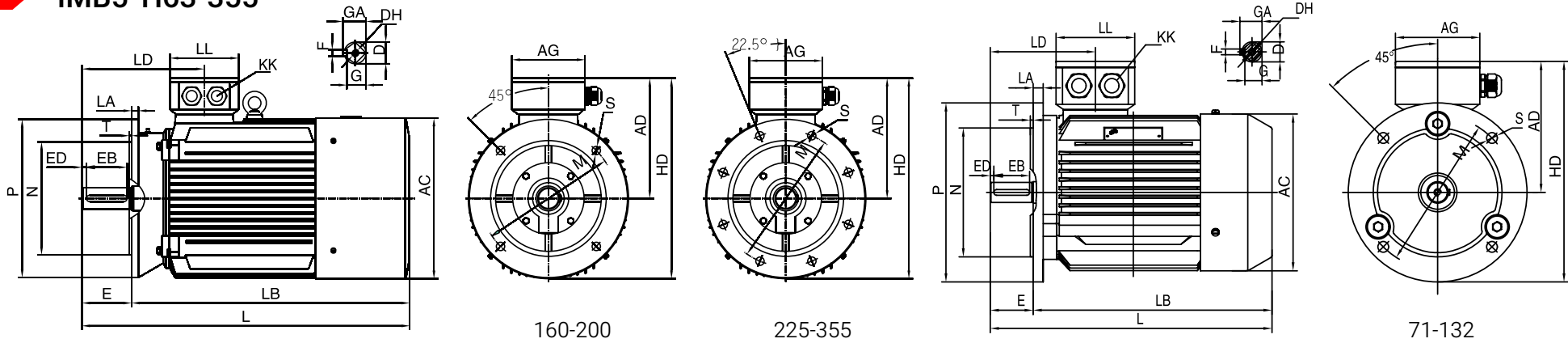

Type	Pole	AC	AD	AG	D	DH	E	EB	ED	F	G	GA	HD	KK	L	LA	LB	LD	LL	M	N	P	S	T
71	2,4,6	136	119	94	14	M5X12	30	25	2.5	5	11	16	199	1-M20X1.5	242	10	212	99	94	130	110	160	10	3.5
80	2,4,6,8	155.4	131	94	19	M6X16	40	30	5	6	15.5	21.5	231	1-M25X1.5	284	12	244	112	94	165	130	200	12	3.5
90S	8	175.4	148	102	24	M8X19	50	40	5	8	20	27	248	1-M25X1.5	318	12	258	130	102	165	130	200	12	3.5
90L	2,4,6,8	175.4	148	102	24	M8X19	50	40	5	8	220	27	248	1-M25X1.5	343	12	283	130	102	165	130	200	12	3.5
100L	8	195.4	162	102	28	M10X22	60	50	5	8	24	31	287	1-M32X1.5	370	13	320	139	102	215	180	250	14.5	4
112M	2,4,6,8	219.4	183	118	28	M10X22	60	50	5	8	24	31	308	2-M32X1.5	394	14	334	147	110	215	180	250	14.5	4
132S	8	258.4	203	118	38	M12X28	80	65	7.5	10	33	41	353	2-M32X1.5	456	14	390	172	110	265	230	300	14.5	4
132M	8	258.4	203	118	38	M12X28	80	65	7.5	10	33	41	353	2-M32X1.5	494	14	428	172	110	265	230	300	14.5	4
160M	2,4,6,8	314	251	162	42	M16X36	110	90	10	12	37	45	426	2-M40X1.5	608	15	498	256	152	300	250	350	18.5	5
160L	2,4,6,8	314	251	162	42	M16X36	110	90	10	12	37	45	426	2-M40X1.5	652	15	542	256	152	300	250	350	18.5	5
180M	8	355	267	162	48	M16X36	110	90	10	14	42.5	51.5	444.5	2-M40X1.5	688	15	578	271	152	300	250	350	18.5	5
180L	8	355	267	162	48	M16X36	110	90	10	14	42.5	51.5	444.5	2-M40X1.5	726	15	616	271	152	300	250	350	18.5	5
200L	2,4,6,8	397	299	210	55	M20X42	110	100	5	16	49	59	499	2-M50X1.5	771	17	661	296	190	350	300	400	18.5	5
225S	8	446	322	210	60	M20X42	140	125	7.5	18	53	64	547	2-M50X1.5	824	20	684	329	190	400	350	450	18.5	5
225M	2	446	322	210	55	M20X42	110	100	5	16	49	59	547	2-M50X1.5	819	20	709	299	190	400	350	450	18.5	5
225M	8	446	322	210	60	M20X42	140	125	7.5	18	53	64	547	2-M50X1.5	849	20	709	329	190	400	350	450	18.5	5

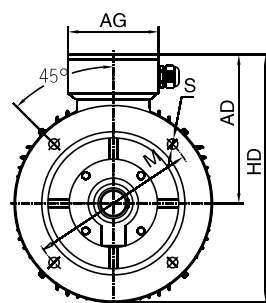
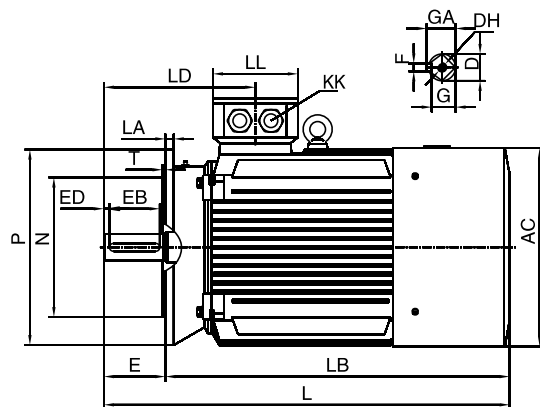

160-200

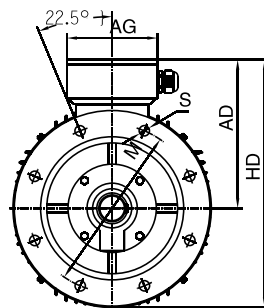

225-355

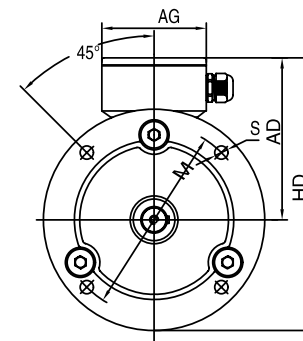
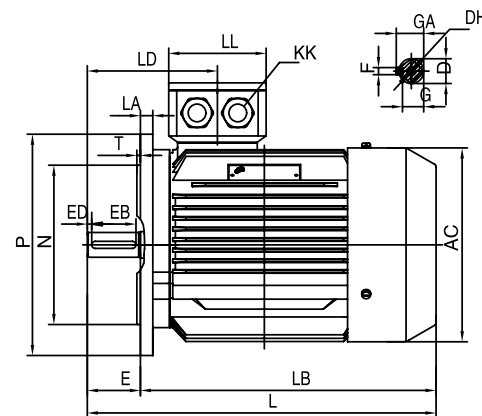

71-132

Type	Pole	AC	AD	AG	D	DH	E	EB	ED	F	G	GA	HD	KK	L	LA	LB	LD	LL	M	N	P	S	T
250M	2	485	358	248	60	M20X42	140	125	7.5	18	53	64	633	2-M63X1.5	910	22	770	347	218	500	450	550	18.5	5
250M	8	485	358	248	65	M20X42	140	125	7.5	18	58	69	633	2-M63X1.5	910	22	770	347	218	500	450	550	18.5	5
280S	2	547	387	248	65	M20X42	140	125	7.5	18	58	69	662	2-M63X1.5	982	22	842	355.5	218	500	450	550	18.5	5
280S	8	547	387	248	75	M20X42	140	125	7.5	20	67.5	79.5	662	2-M63X1.5	982	22	842	355.5	218	500	450	550	18.5	5
280M	2	547	387	248	65	M20X42	140	125	7.5	18	58	69	662	2-M63X1.5	1033	22	893	355.5	218	500	450	550	18.5	5
280M	4,6,8	547	387	248	75	M20X42	140	125	7.5	20	67.5	79.5	662	2-M63X1.5	1033	22	893	355.5	218	500	450	550	18.5	5
315S	2	620	527	320	65	M20X42	140	125	7.5	18	58	69	857	2-M63X1.5	1178	22	1038	397	280	600	550	660	24	6
315S	10	620	527	320	80	M20X42	170	160	5	22	71	85	857	2-M63X1.5	1208	22	1038	427	280	600	550	660	24	6
315M	2	620	527	320	65	M20X42	140	125	7.5	18	58	69	857	2-M63X1.5	1288	22	1148	397	280	600	550	660	24	6
315M	4,6,8,10	620	527	320	80	M20X42	170	160	5	22	71	85	857	2-M63X1.5	1318	22	1148	427	280	600	550	660	24	6
315L	2	620	527	320	65	M20X42	140	125	7.5	18	58	69	857	2-M63X1.5	1288	22	1148	397	280	600	550	660	24	6
315L	10	620	527	320	80	M20X42	170	160	5	22	71	85	857	2-M63X1.5	1318	22	1148	427	280	600	550	660	24	6
355M	2	698	642	380	75	M20X42	140	130	5	20	67.5	79.5	1042	2-M63X1.5	1486	25	1346	414	330	740	680	800	24	6
355M	4,6,8,10	698	642	380	95	M24X50	170	160	5	25	86	100	1042	2-M63X1.5	1516	25	1346	444	330	740	680	800	24	6
355L	2	698	642	380	75	M20X42	140	130	5	20	67.5	79.5	1042	2-M63X1.5	1486	25	1346	414	330	740	680	800	24	6
355L	10	698	642	380	95	M24X50	170	160	5	25	86	100	1042	2-M63X1.5	1516	25	1346	444	330	740	680	800	24	6

► **IMB35 H63-355**

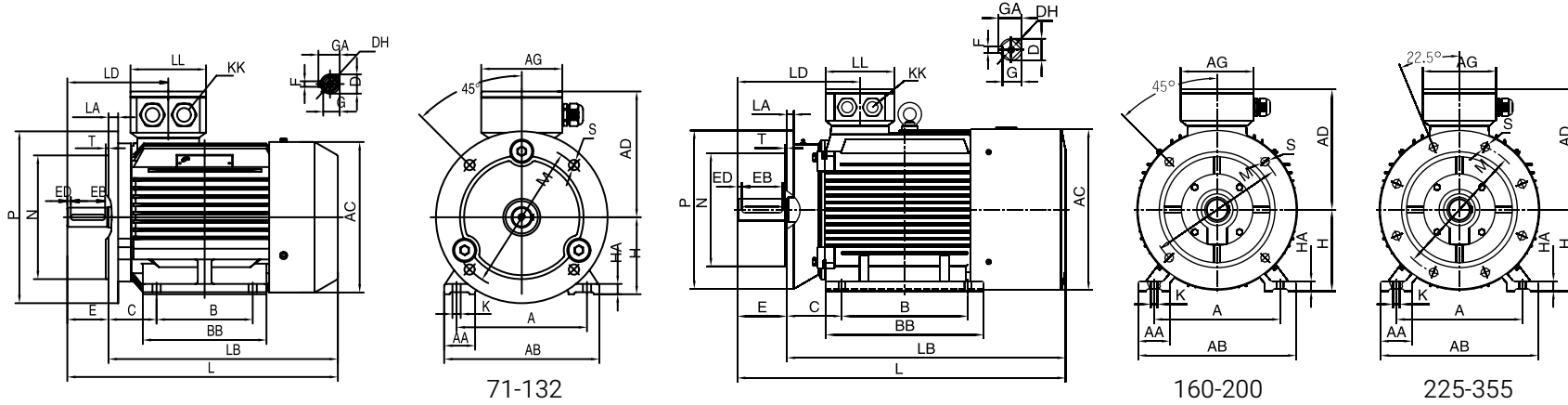

Type	Pole	A	AA	AB	AC	AD	AG	B	BB	C	D	DH	E	EB	ED	F
71	2,4,6	112	32	144	136	119	94	90	120	45	14	M5X12	30	25	2.5	5
80	2,4,6,8	125	34	160	155.4	131	94	100	130	50	19	M6X16	40	30	5	6
90S	2,4,6,8	140	36	176	175.4	148	102	100	130	56	24	M8X19	50	40	5	8
90L	2,4,6,8	140	36	176	175.4	148	102	125	155	56	24	M8X19	50	40	5	8
100L	2,4,6,8	160	40	200	195.4	162	102	140	176	63	28	M10X22	60	50	5	8
112M	2,4,6,8	190	45	226	219.4	183	118	140	180	70	28	M10X22	60	50	5	8
132S	2,4,6,8	216	55	262	258.4	203	118	140	186	89	38	M12X28	80	65	7.5	10
132M	4,6,8	216	55	262	258.4	203	118	178	224	89	38	M12X28	80	65	7.5	10
160M	2,4,6,8	254	65	314	314	251	162	210	260	108	42	M16X36	110	90	10	12
160L	2,4,6,8	254	65	314	314	251	162	254	304	108	42	M16X36	110	90	10	12
180M	2,4,8	279	70	349	355	267	162	241	311	121	48	M16X36	110	90	10	14
180L	4,6,8	279	70	349	355	267	162	279	349	121	48	M16X36	110	90	10	14
200L	2,4,6,8	318	70	388	397	299	210	305	369	133	55	M20X42	110	100	5	16
225S	4,8	356	75	431	446	322	210	286	368	149	60	M20X42	140	125	7.5	18
225M	2	356	75	431	446	322	210	311	393	149	55	M20X42	110	100	5	16
225M	4,6,8	356	75	431	446	322	210	311	393	149	60	M20X42	140	125	7.5	18

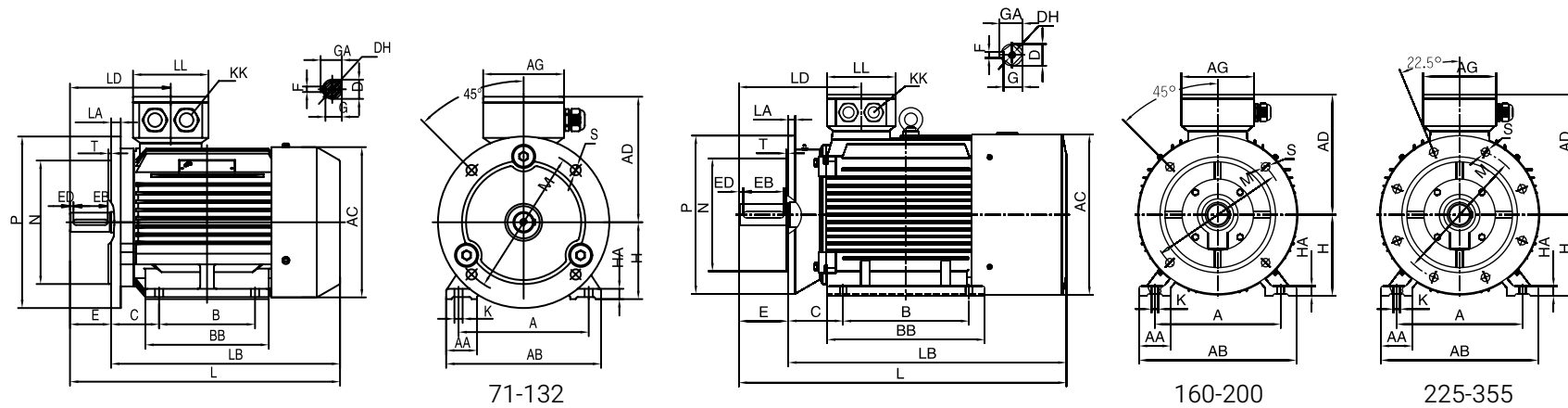

71-132

160-200

225-355

Type	G	GA	H	HA	K	KK	L	LA	LB	LD	LL	M	N	P	S	T
71	11	16	71	8	4-φ7	1-M20X1.5	242	10	212	99 90	94	130	110	160	10	3.5
80	15.5	21.5	80	10	4-φ10	1-M25X1.5	284	12	244	112	94	165	130	200	12	3.5
90S	20	27	90	12	4-φ10	1-M25X1.5	318	12	258	130	102	165	130	200	12	3.5
90L	20	27	90	12	4-φ10	1-M25X1.5	343	12	283	130	102	165	130	200	12	3.5
100L	24	31	100	14	4-φ12	1-M32X1.5	370	13	320	139	102	215	180	250	14.5	4
112M	24	31	112	15	4-φ12	2-M32X1.5	394	14	334	147	110	215	180	250	14.5	4
132S	33	41	132	18	4-φ12	2-M32X1.5	456	14	390	172	110	265	230	300	14.5	4
132M	33	41	132	18	4-φ12	2-M32X1.5	494	14	428	172	110	265	230	300	14.5	4
160M	37	45	160	20	4-φ14.5	2-M40X1.5	608	15	498	256	152	300	250	350	18.5	5
160L	37	45	160	20	4-φ14.5	2-M40X1.5	652	15	542	256	152	300	250	350	18.5	5
180M	42.5	51.5	180	22	4-φ14.5	2-M40X1.5	688	15	578	271	152	300	250	350	18.5	5
180L	42.5	51.5	180	22	4-φ14.5	2-M40X1.5	726	15	616	271	152	300	250	350	18.5	5
200L	49	59	200	25	4-φ18.5	2-M50X1.5	771	17	661	296	190	350	300	400	18.5	5
225S	53	64	225	28	4-φ18.5	2-M50X1.5	824	20	684	329	190	400	350	450	18.5	5
225M	49	59	225	28	4-φ18.5	2-M50X1.5	819	20	709	299	190	400	350	450	18.5	5
225M	53	64	225	28	4-φ18.5	2-M50X1.5	849	20	709	329	190	400	350	450	18.5	5

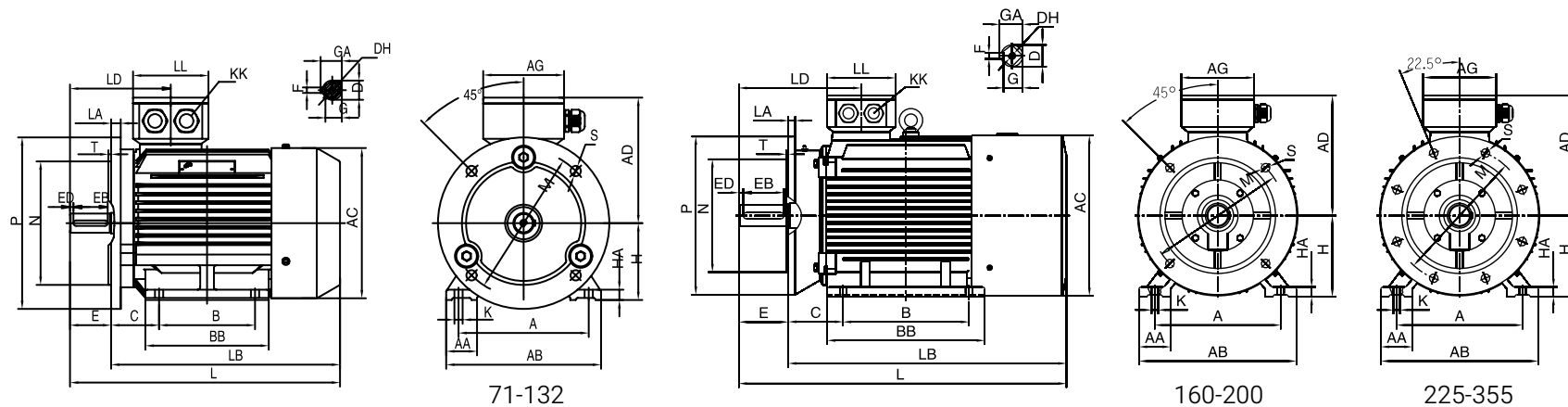

71-132

160-200

225-355

Type	G	GA	H	HA	K	KK	L	LA	LB	LD	LL	M	N	P	S	T
250M	53	64	250	30	4 - φ 24	2-M63X1.5	910	22	770	347	218	500	450	550	18.5	5
250M	58	69	250	30	4 - φ 24	2-M63X1.5	910	22	770	347	218	500	450	550	18.5	5
280S	58	69	280	35	4 - φ 24	2-M63X1.5	982	22	842	355.5	218	500	450	550	18.5	5
280S	67.5	79.5	280	35	4 - φ 24	2-M63X1.5	982	22	842	355.5	218	500	450	550	18.5	5
280M	58	69	280	35	4 - φ 24	2-M63X1.5	1033	22	893	355.5	218	500	450	550	18.5	5
280M	67.5	79.5	280	35	4 - φ 24	2-M63X1.5	1033	22	893	355.5	218	500	450	550	18.5	5
315S	58	69	315	45	4 - φ 28	2-M63X1.5	1178	22	1038	397	280	600	550	660	24	6
315S	71	85	315	45	4 - φ 28	2-M63X1.5	1208	22	1038	427	280	600	550	660	24	6
315M	58	69	315	45	4 - φ 28	2-M63X1.5	1288	22	1148	397	280	600	550	660	24	6
315M	71	85	315	45	4 - φ 28	2-M63X1.5	1318	22	1148	427	280	600	550	660	24	6
315L	58	69	315	45	4 - φ 28	2-M63X1.5	1288	22	1148	397	280	600	550	660	24	6
315L	71	85	315	45	4 - φ 28	2-M63X1.5	1318	22	1148	427	280	600	550	660	24	6
355M	67.5	79.5	355	52	6 - φ 28	2-M63X1.5	1486	25	1346	414	330	740	680	800	24	6
355M	86	100	355	52	6 - φ 28	2 - M63X1.5	1516	25	1346	444	330	740	680	800	24	6
355L	67.5	79.5	355	52	6 - φ 28	2 - M63X1.5	1486	25	1346	414	330	740	680	800	24	6
355L	86	100	355	52	6 - φ 28	2 - M63X1.5	1516	25	1346	444	330	740	680	800	24	6

► IMV1 H160-355

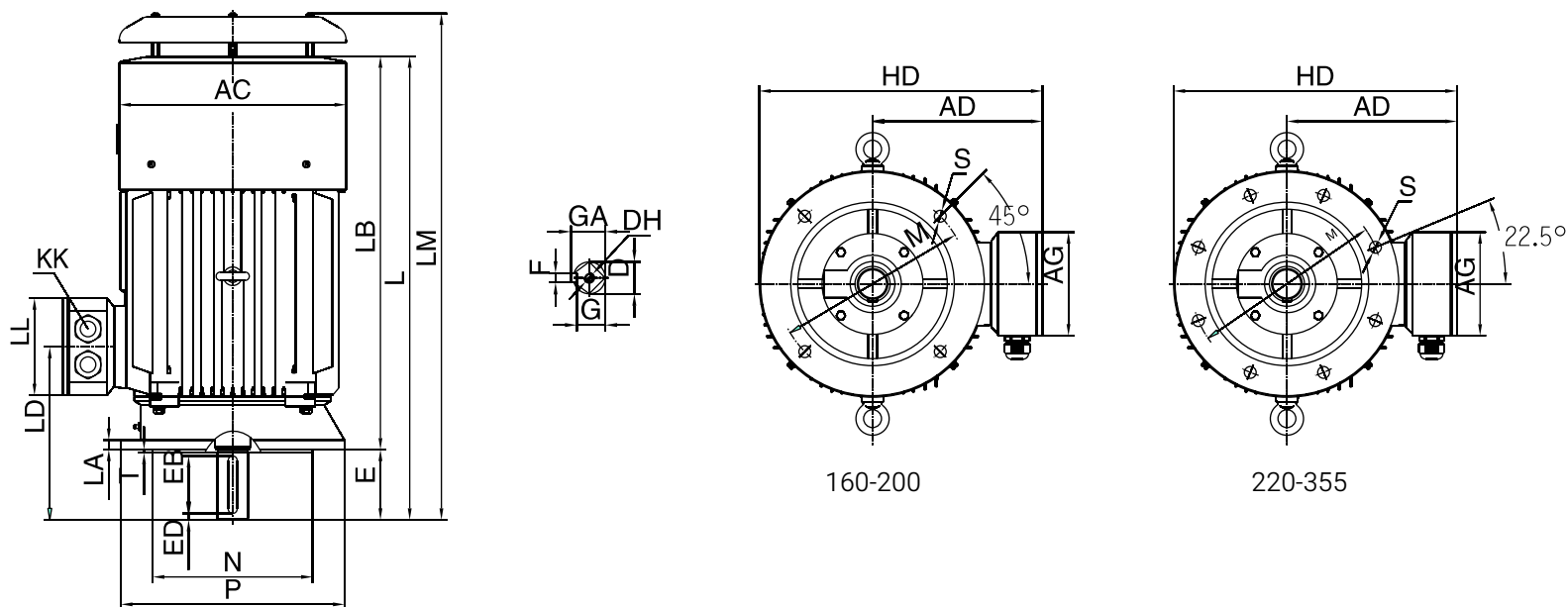

Type	Pole	AC	AD	AG	D	DH	E	EB	ED	F	G	GA	HD	KK	L	LA	LB	LD	LL	LM	M	N	P	S	T
160M	2,4,6,8	314	251	162	42	M16X36	110	90	10	12	37	45	426	2-M40X1.5	608	15	498	256	152	670	300	250	350	18.5	5
160L	2,4,6,8	314	251	162	42	M16X36	110	90	10	12	37	45	426	2-M40X1.5	652	15	542	256	152	714	300	250	350	18.5	5
180M	2,4,8,8	355	267	162	48	M16X36	110	90	10	14	42.5	51.5	444.5	2-M40X1.5	688	15	578	271	152	760	300	250	350	18.5	5
180L	4,6,8,8	355	267	162	48	M16X36	110	90	10	14	42.5	51.5	444.5	2-M40X1.5	726	15	616	271	152	798	300	250	350	18.5	5
200L	2,4,0,8	397	299	210	55	M20X42	110	100	5	16	49	59	499	2-M50X1.5	771	17	661	296	190	845	350	300	400	18.5	5
225S	4,8,2,8	446	322	210	60	M20X42	140	125	7.5	18	53	64	547	2-M50X1.5	824	20	684	329	190	898	400	350	450	18.5	5
225M	2	446	322	210	55	M20X42	110	100	5	16	49	59	547	2-M50X1.5	819	20	709	299	190	893	400	350	450	18.5	5
225M	4,6,2,8	446	322	210	60	M20X42	140	125	7.5	18	53	64	547	2-M50X1.5	849	20	709	329	190	893	400	350	450	18.5	5
250M	2	485	358	248	60	M20X42	140	125	7.5	18	53	64	633	2-M63X1.5	910	22	770	347	218	986	500	450	550	18.5	5
250M	4,6,5,8	485	358	248	65	M20X42	140	125	7.5	18	58	69	633	2-M63X1.5	910	22	770	347	218	986	500	450	550	18.5	5
280S	2	547	387	248	65	M20X42	140	125	7.5	18	58	69	662	2-M63X1.5	982	22	842	355.5	218	1058	500	450	550	18.5	5
280S	4,6,8,8	547	387	248	75	M20X42	140	125	7.5	20	67.5	79.5	662	2-M63X1.5	982	22	842	355.5	218	1058	500	450	550	18.5	5

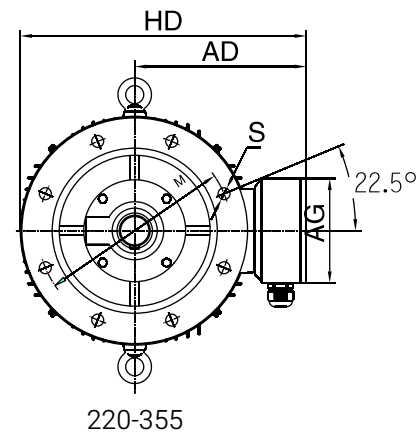
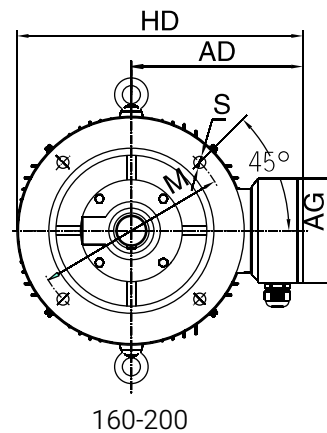
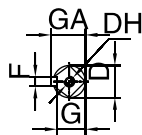
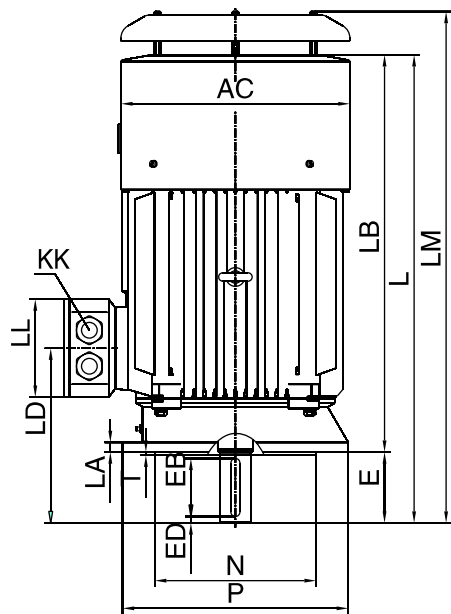

Type	Pole	AC	AD	AG	D	DH	E	EB	ED	F	G	GA	HD	KK	L	LA	LB	LD	LL	LM	M	N	P	S	T
280M	2	547	387	248	65	M20X42	140	125	7.5	18	58	69	662	2-M63X1.5	1033	22	893	355.5	218	1109	500	450	550	18.5	5
280M	4,6,8,8	547	387	248	75	M20X42	140	125	7.5	20	67.5	79.5	662	2-M63X1.5	1033	22	893	355.5	218	1109	500	450	550	18.5	5
315S	2	620	527	284	65	M20X42	140	125	7.5	18	58	69	857	2-M63X1.5	1178	22	1038	397	280	1259	600	550	660	24	6
315S	4,6,1,10	620	527	284	80	M20X42	170	160	5	22	71	85	857	2-M63X1.5	1208	22	1038	427	280	1289	600	550	660	24	6
315M	2	620	527	284	65	M20X42	140	125	7.5	18	58	69	857	2-M63X1.5	1288	22	1148	397	280	1369	600	550	660	24	6
315M	4,6,1,10	620	527	284	80	M20X42	170	160	5	22	71	85	857	2-M63X1.5	1318	22	1148	427	280	1399	600	550	660	24	6
315L	2	620	527	284	65	M20X42	140	125	7.5	18	58	69	857	2-M63X1.5	1288	22	1148	397	280	1369	600	550	660	24	6
315L	4,6,1,10	620	527	284	80	M20X42	170	160	5	22	71	85	857	2-M63X1.5	1318	22	1148	427	280	1399	600	550	660	24	6
355M	2	698	642	380	75	M20X42	140	130	5	20	67.5	79.5	1042	2-M63X1.5	1486	25	1346	414	330	1567	740	680	800	24	6
355M	4,6,5,10	698	642	380	95	M24X50	170	160	5	25	86	100	1042	2-M63X1.5	1516	25	1346	444	330	1597	740	680	800	24	6
355L	2	698	642	380	75	M20X42	140	130	5	20	67.5	79.5	1042	2-M63X1.5	1486	25	1346	414	330	1567	740	680	800	24	6
355L	4,6,5,10	698	642	380	95	M24X50	170	160	5	25	86	100	1042	2-M63X1.5	1516	25	1346	444	330	1597	740	680	800	24	6