



Vibration motor



# 4 POLE

50 Hz-1500 rpm ~ 60 Hz-1800 rpm



\*Please contact us for 60 Hz values.

MECHANICAL SPECIFICATIONS						ELECTRICAL SPECIFICATIONS		
RPM	TYPE	Centrifugal Force		Static Moment	Weight	Nominal Voltage	Max. Current	Max. Input Power
50 Hz		KG	N	kgmm	KG	V	A	Kw
1500	VA 4-50	50	491	20	6,9	230/400	0,52/0,30	0,15
	VA 4-80	80	785	32	7,6	230/400	0,52/0,30	0,15
	VB 4-200	210	2060	84	12,1	230/400	0,72/0,42	0,17
	VC 4-400	400	3924	159	19,0	230/400	1,30/0,75	0,35
	VC 4-600	570	5592	227	20,1	230/400	1,30/0,75	0,35
	VD 4-750	750	7358	298	30,0	230/400	1,73/1,00	0,6
	VD 4-1100	1100	10791	437	33,0	230/400	2,16/1,25	0,7
	VE 4-1500	1480	14519	588	62,0	230/400	4,33/2,50	1,25
	VE 4-1800	1740	17069	692	64,5	230/400	4,76/2,75	1,25
	VE 4-2100	2080	20405	827	67,5	230/400	4,76/2,75	1,4
	VG 4-2600	2560	25113	1018	82,0	230/400	5,71/3,30	1,6
	VG 4-3200	3290	32275	1308	88,0	230/400	6,58/3,80	1,9
	VH 4-4000	3981	39053	1583	103,0	230/400	6,75/3,90	2,1
	VH 4-4500	4584	44969	1823	108,0	230/400	8,31/4,80	2,4
	VK 4-5000	5000	49050	1988	144,0	230/400	10,65/6,15	3,6
	VK 4-6000	6000	58860	2386	151,0	230/400	10,65/6,15	3,6
VL 4-7500	7423	72820	2951	197,0	400/690	13,00/7,50	7,0	
VL 4-9000	9197	90223	3657	206,0	400/690	13,00/7,50	7,0	

Working Moment = 2 x Static Moment

\*We reserve the right to modify the specifications and dimensions without notice.

Figure 1

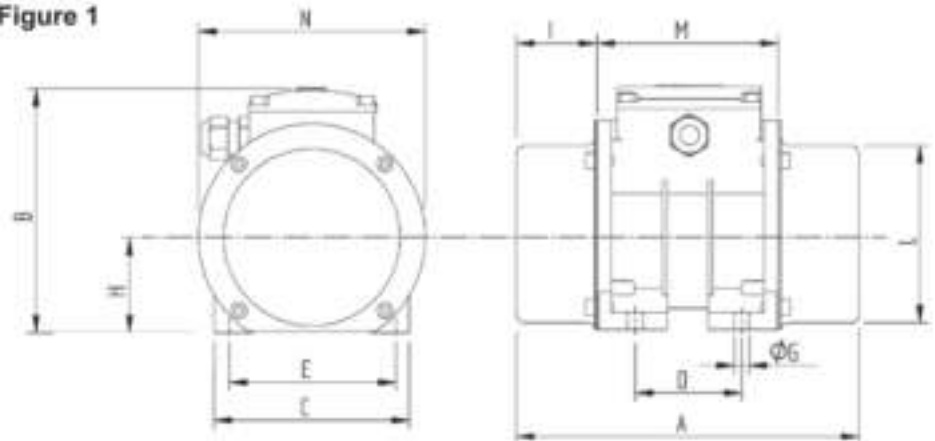

DIMENSIONS (mm)

TYPE	A	B	C	D	E	ØGx4	H	I	L	M	N	Cable Entry	Fig. No
VA 4-50	219	156	125	74-62	106	9	62	51,5	113	116	145	M20 x 1,5	1
VA 4-80	219	156	125	74-62	106	9	62	51,5	113	116	145	M20 x 1,5	1
VB 4-200	285	175	152	90	125	13	75	66,5	130	152	162	M20 x 1,5	1
VC 4-400	306	196	172	95-105	140	13	86	77	151	152	191	M20 x 1,5	1
VC 4-600	331	196	172	95-105	140	13	86	89,5	151	152	191	M20 x 1,5	1
VD 4-750	368	235	210	120	170	17	109	89	188	190	230	M20 x 1,5	1
VD 4-1100	416	235	210	120	170	17	109	113	188	190	230	M20 x 1,5	1
VE 4-1500	520	253	235	140	190	17	116	131	212	259	274	M20 x 1,5	2
VE 4-1800	520	253	235	140	190	17	116	131	212	259	274	M20 x 1,5	2
VE 4-2100	520	253	235	140	190	17	116	131	212	259	274	M20 x 1,5	2
VG 4-2600	522	277	270	155	225	22	130	116	234	290	294	M20 x 1,5	2
VG 4-3200	628	277	270	155	225	22	130	169	234	290	294	M20 x 1,5	2
VH 4-4000	548	334	310	155	255	23,5	160	119	292	310	330	M25 x 1,5	2
VH 4-4500	604	334	310	155	255	23,5	160	147	292	310	330	M25 x 1,5	2
VK 4-5000	612	356	340	180	280	26	170	140,5	310	330	327	M25 x 1,5	2
VK 4-6000	612	356	340	180	280	26	170	140,5	310	330	327	M25 x 1,5	2
VL 4-7500	692	400	390	200	320	28	195	163	383	365	384	M25 x 1,5	2
VL 4-9000	692	400	390	200	320	28	195	163	383	365	384	M25 x 1,5	2

Figure 2

